

SEARS

OWNERS MANUAL

MODEL NO.
900.271221

CAUTION
Read Rules for
Safe Operation
and Instructions
Carefully

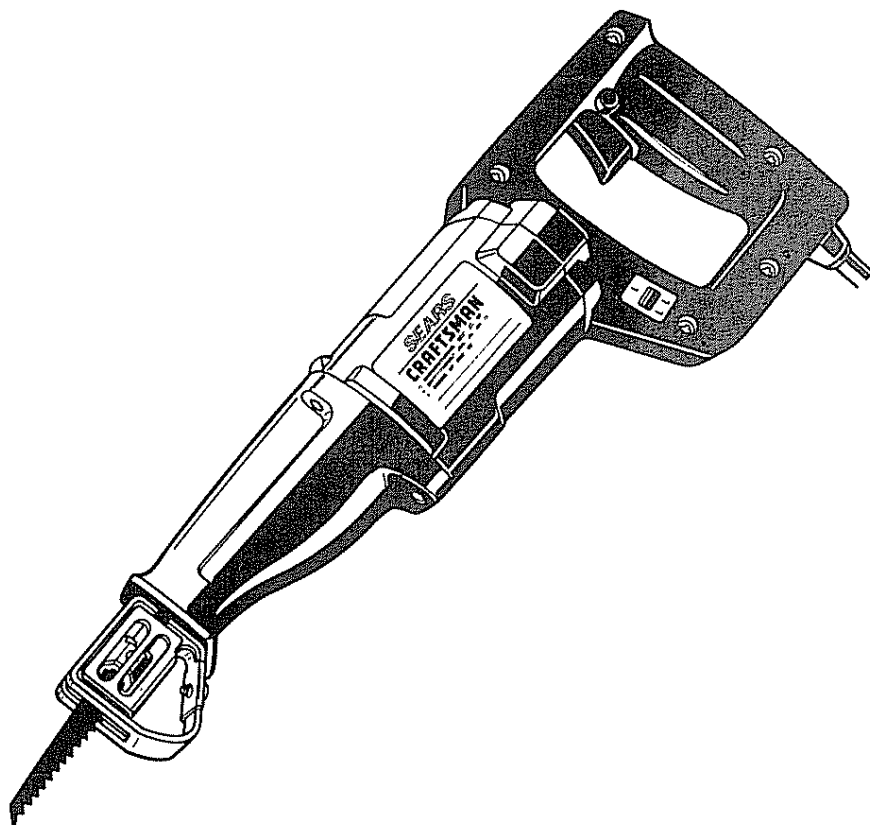

CRAFTSMAN®

DUAL SPEED

RECIPROCATING SAW

DOUBLE INSULATED

Introduction
Operation
Maintenance
Repair Parts



sold by SEARS, ROEBUCK AND CO., Chicago, IL 60684 U.S.A.

Form No. 446901-07

(JUL91-CD-1)

PRINTED IN U.S.A.

FULL ONE YEAR WARRANTY ON CRAFTSMAN INDUSTRIAL PORTABLE RECIPROCATING SAW

If this CRAFTSMAN Industrial Reciprocating Saw fails due to a defect in material or workmanship within one year from the date of purchase, Sears will repair it free of charge.

WARRANTY SERVICE IS AVAILABLE BY SIMPLY RETURNING THE TOOL TO THE NEAREST SEARS STORE OR SERVICE CENTER THROUGHOUT THE UNITED STATES

THIS WARRANTY GIVES YOU SPECIFIC LEGAL RIGHTS AND YOU MAY ALSO HAVE OTHER RIGHTS WHICH VARY FROM STATE TO STATE

SEARS, ROEBUCK AND CO., DEPT 698/731 A, SEARS TOWER, CHICAGO, IL 60684

INTRODUCTION

DOUBLE INSULATION

Double insulation is a concept in safety, in electric power tools, which eliminates the need for the usual three wire grounded power cord and grounded supply system. Wherever there is electric current in the tool there are two complete sets of insulation to protect the user. All exposed metal parts are isolated from the internal metal motor components with protecting insulation.

IMPORTANT

Servicing of a tool with double insulation requires extreme care and knowledge of the system and should be performed only by a qualified service technician. For service we suggest you return the tool to your nearest Sears Store for repair. Always use original factory replacement parts when servicing.

IMPORTANT SAFETY INSTRUCTIONS (FOR ALL TOOLS)

WARNING: When using Electric Tools, basic safety precautions should always be followed to reduce the risk of fire, electric shock, and personal injury, including the following:

READ ALL INSTRUCTIONS

- KEEP WORK AREA CLEAN.** Cluttered areas and benches invite injuries.
- CONSIDER WORK AREA ENVIRONMENT.** Don't expose power tools to rain. Don't use power tools in damp or wet locations. Keep work area well lit.
- GUARD AGAINST ELECTRIC SHOCK.** Prevent body contact with grounded surfaces. For example: pipes, radiators, ranges, refrigerator enclosures.
- KEEP CHILDREN AWAY.** All visitors should be kept away from work area. Do not let visitors contact tool or extension cord.
- STORE IDLE TOOLS.** When not in use, tools should be stored in dry, and high or locked-up place—out of reach of children.
- DON'T FORCE TOOL.** It will do the job better and safer at the rate for which it was intended.
- USE RIGHT TOOL.** Don't force small tool or attachment to do the job of a heavy-duty tool. Don't use tool for purpose not intended, for example, don't use circular saw for cutting tree limbs or logs.
- DRESS PROPERLY.** Do not wear loose clothing or jewelry. They can be caught in moving parts. Rubber gloves and non-skid footwear are recommended when working outdoors. Wear protective hair covering to contain long hair.
- USE SAFETY GLASSES.** Also use face or dustmask if cutting operation is dusty.
- DON'T ABUSE CORD.** Never carry tool by cord or yank it to disconnect from receptacle. Keep cord from heat, oil, and sharp edges.
- SECURE WORK.** Use clamps or a vise to hold work. It's safer than using your hand and it frees both hands to operate tool.
- DON'T OVERREACH.** Keep proper footing and balance at all times.
- MAINTAIN TOOLS WITH CARE.** Keep tools sharp and clean for better and safe performance. Follow instructions for lubricating and changing accessories. Inspect tool cords periodically and if damaged have repaired by authorized service facility. Inspect extension cords periodically and replace if damaged. Keep handles dry, clean and free from oil and grease.
- DISCONNECT TOOLS.** When not in use, before servicing, and when changing accessories, such as blades, bits, cutters.
- REMOVE ADJUSTING KEYS AND WRENCHES.** Form habit of checking to see that keys and adjusting wrenches are removed from tool before turning it on.
- AVOID UNINTENTIONAL STARTING.** Don't carry plugged-in tool with finger on switch. Be sure switch is off when plugging in.
- OUTDOOR USE EXTENSION CORDS.** When tool is used outdoors, use only extension cords intended for use outdoors and so marked.
- STAY ALERT.** Watch what you are doing. Use common sense. Do not operate tool when you are tired.
- CHECK DAMAGED PARTS.** Before further use of the tool, a guard or other part that is damaged should be carefully checked to determine that it will operate properly and perform its intended function. Check for alignment of moving parts, binding of moving parts, breakage of parts, mounting and any other conditions that may affect its operation. A guard or other part that is damaged should be properly repaired or replaced by an authorized service center unless otherwise indicated elsewhere in this instruction manual. Have defective switches replaced by authorized service center. Do not use tool if switch does not turn it on and off.
- DO NOT OPERATE** portable electric tools near flammable liquids or in gaseous or explosive atmospheres. Motors in these tools normally spark, and the sparks might ignite fumes.

ADDITIONAL SAW SAFETY RULES

- KEEP HANDS AWAY** from cutting area. Never reach underneath the material for any reason.
- KEEP BLADE SHARP.** Dull blades may cause the saw to swerve or stall under pressure.

SAVE THESE INSTRUCTIONS

SWITCH

Depress the **Trigger Switch** to turn tool "ON". Releasing the trigger turns tool "OFF". To lock the trigger switch in the "ON" position for continuous operation, depress the trigger, push in locking button on left side of handle and then release the trigger. To release locking mechanism, depress trigger fully, then release it.

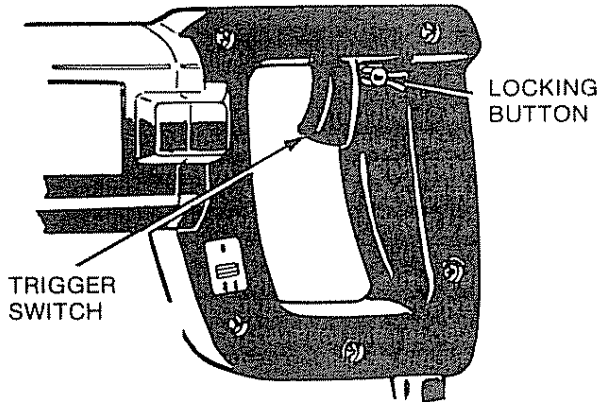

The Dual Speed Reciprocating Saw offers a choice of speeds for greatly improved cutting rates in various materials. Note that the High-Speed setting is more efficient in softer materials such as wood, while the Low-Speed is best for cutting metals.

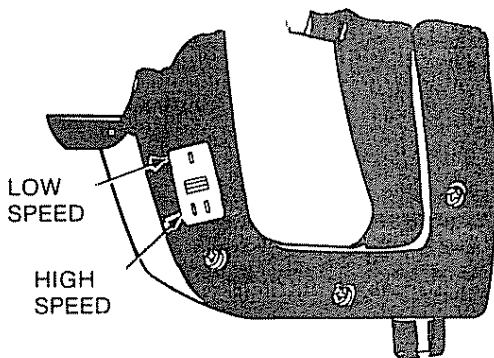

LOW SPEED (Move slide switch to show (I) bar). For cutting sheet metal, metal pipe, metal conduit, etc.

HIGH SPEED (Move slide switch to show (II) bar). For cutting wood, plastic, composition boards and other similar materials.

MOTOR

Be sure your power supply agrees with the nameplate marking **VOLTS 50/60 Hz or AC ONLY** means your tool must be operated only with Alternating Current and **never** with Direct Current. **VOLTS DC-60 Hz or AC/DC** means your tool may be operated with either Alternating or Direct Current. Voltage decrease of more than 10% will cause loss of power or overheating. All tools are factory-tested; if this tool does not operate, check the power supply.

OPERATION

BLADE CLAMPING

To install blade into saw:

- 1 Loosen set screw
- 2 Insert blade shank from the front between the reciprocating shaft and the blade clamp.

Locate hole in blade over pin on reciprocating shaft

- 3 Tighten set screw

If the blade should break off and the shank does not come out of the clamp, be sure the set screw is loose and eject the shank with a nail or pointed object.

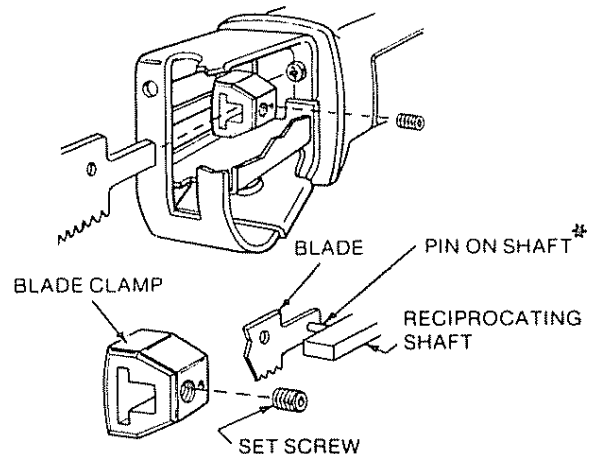

* NOTE: A special pin holds the blade clamp on the reciprocating shaft to prevent the clamp from coming off when set screw is loosened.

SAVE THESE INSTRUCTIONS

FLUSH-TO CUTTING

The exclusive, compact design of the motor housing and spindle housing permits extremely close cutting to floors, corners and other difficult areas. (See below)

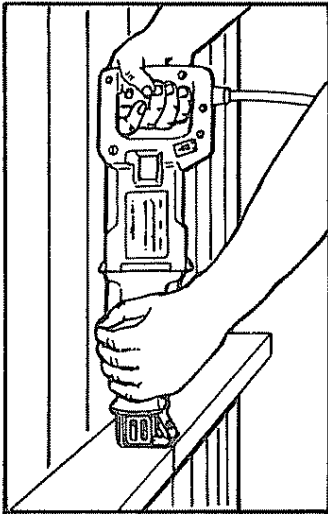

CAUTION: When sawing into walls, floors or wherever "live" electrical wires may be encountered, DO NOT TOUCH ANY METAL PARTS OF THE TOOL! Hold the tool only by the plastic handle and housing to prevent electric shock if you saw into a "live" wire

CAUTION: Always wear eye protection while operating this power tool

WOOD CUTTING

Before cutting any type of wood, be sure it is firmly anchored or clamped to prevent slipping. Check blade chart for type and length of blade necessary for best results. Place blade lightly against work to be cut, switch on saw motor and allow it to obtain maximum speed before applying pressure. Always hold saw firmly with both hands while cutting. Whenever possible, the saw shoe must be held firmly against the material being cut. This will prevent the saw from jumping or vibrating and minimize blade breakage.

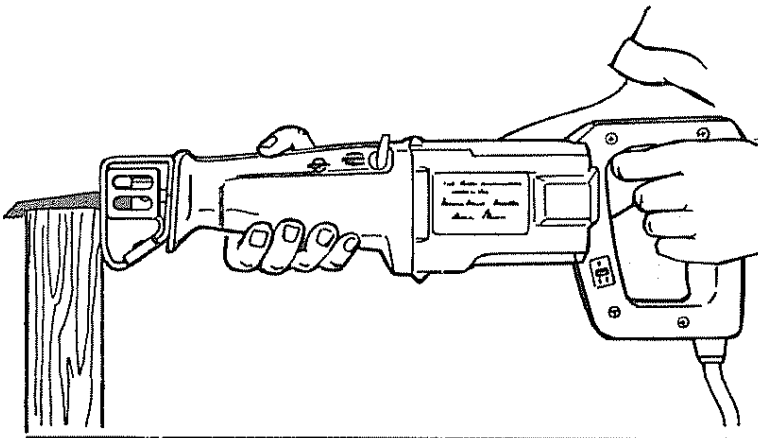

POCKET CUTTING

The initial step in pocket cutting is to measure the surface area to be cut and mark clearly with a pencil, chalk or scribe. Insert pocket cutting blade clamp, and tighten blade clamp securely. Next, tip the saw backward until the back edge of the shoe is resting on the work surface. Now switch motor on, always permitting blade to attain maximum speed. Grip handle steadily and begin a slow, deliberate upward swing with the handle end of the saw. Blade will begin to feed into material. Always be sure blade is completely through material before continuing with pocket cut.

NOTE: In areas where blade visibility is limited, use the edge of the saw shoe as a guide. Lines for any given cut should be extended beyond edge of cut to be made.

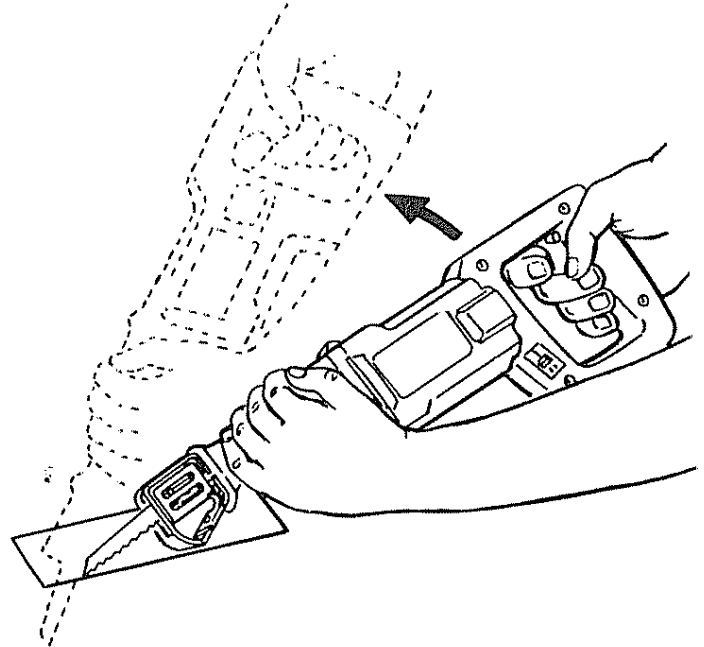

METAL CUTTING

This unit has different metal cutting capacities depending upon type of blade used and on the metal to be cut. Please check Blade Chart for better blade selection. Use a finer blade for ferrous metals and a coarse blade for nonferrous materials. In cutting thin gage sheet metals it is best to clamp wood to both sides of metal sheet. This will insure a clean cut without excess vibration or tearing of metal. Always remember not to force cutting blade as this reduces blade life and causes costly blade breakage.

NOTE: It is generally recommended that when cutting metals you should spread a thin film of oil or other coolant along the cutting line ahead of the saw cut for easier operation and longer blade life. For cutting aluminum, kerosene is preferred.

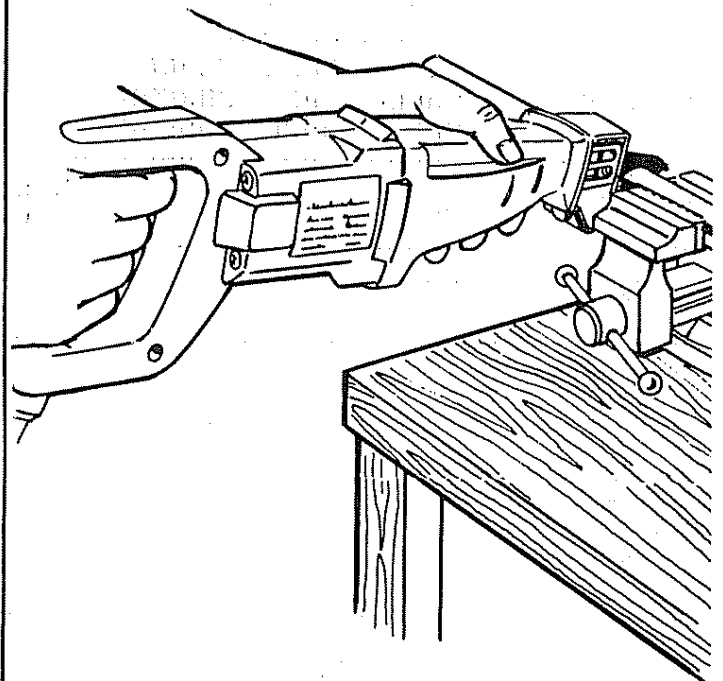

MAINTENANCE

WHEN SERVICING USE ONLY IDENTICAL REPLACEMENT PARTS

GENERAL

Only the parts shown on parts list, page seven, are intended to be repaired or replaced by the customer. All other parts represent an important part of the double insulation system and should be serviced only by a qualified service technician. Avoid using solvents when cleaning plastic parts. Most plastics are susceptible to various types of commercial solvents and may be damaged by their use. Use clean cloths to remove dirt, carbon dust, etc.

When electric tools are used on fiberglass boats, sports cars, etc., it has been found that they are subject to accelerated wear and possible premature failure, as the fiberglass chips and grindings are highly abrasive to bearings, brushes, commutator, etc. Consequently it is not recommended that this tool be used for continuous production work on any fiberglass material. During any use on fiberglass it is extremely important that the tool is cleaned frequently by blowing with an air jet.







Extension Cable Chart						
Find the right size extension cord in the table below. Using the proper cord will prevent motor overheating from loss of power in the extension cord. Recommended size, for safe and efficient operation.						
Current rating (on nameplate)	0-2.00	2.10-3.4	3.5-5.00	5.10-7.0	7.10-12.0	12.1-16.0
Ext. Cable Length	Wire Size					
25 ft	18	18	18	18	16	14
50 ft	16	16	16	16	14	12 Not
75 ft	16	16	16	14	12	10 normally
100 ft	16	16	14	12	10	8 available
150 ft	16	14	12	12	8	8 as flexible
200 ft	16	14	12	10	8	6 extension
300 ft	14	12	10	8	6	4 cord
400 ft	12	10	8	6	4	4
500 ft	12	10	8	6	4	2
600 ft	10	8	6	4	2	2
800 ft	10	8	6	4	2	1
1000 ft	8	6	4	2	1	0

EXTENSION CORDS

When tool is used outdoors, use only extension cords suitable for outdoor use and so marked. Extension cords are available at Sears Catalog Order or Retail Store.

SEARS / CRAFTSMAN®

RECIPROCATING SAW BLADES

ORIGINAL BLADE #	CRAFTSMAN REPLACE-MENT #	TEETH PER INCH	BLADE LENGTH (INCHES)	USES:
40098	28681	7	6	Smooth cuts in wood, plastic, composition board; plunge, scroll cuts. 
40107 (6 inch)	28682	3	9	Fast, rough cuts in wood over 1 inch thick. 
40125	28683	24	6	Steel, other metals up to 2 inches thick. 
40103 (10 T P I)	28684	7	6	Flush cuts, wood, plastic, nails. 
40099	28685	7	12	Smooth, deep cuts through wood, plastic, composition board, hardboard; scroll cuts. 
N/A	28686	14	6	Rough cuts in wood; cuts nails. 

SEARS RECIPROCATING SAW - MODEL NUMBER 900.271221

PARTS SHOWN FOR REFERENCE ONLY

IMPORTANT!—To assure product SAFETY and RELIABILITY, repairs, maintenance and adjustment should be performed by Sears Service Centers or other qualified service organizations, always using Sears replacement parts.

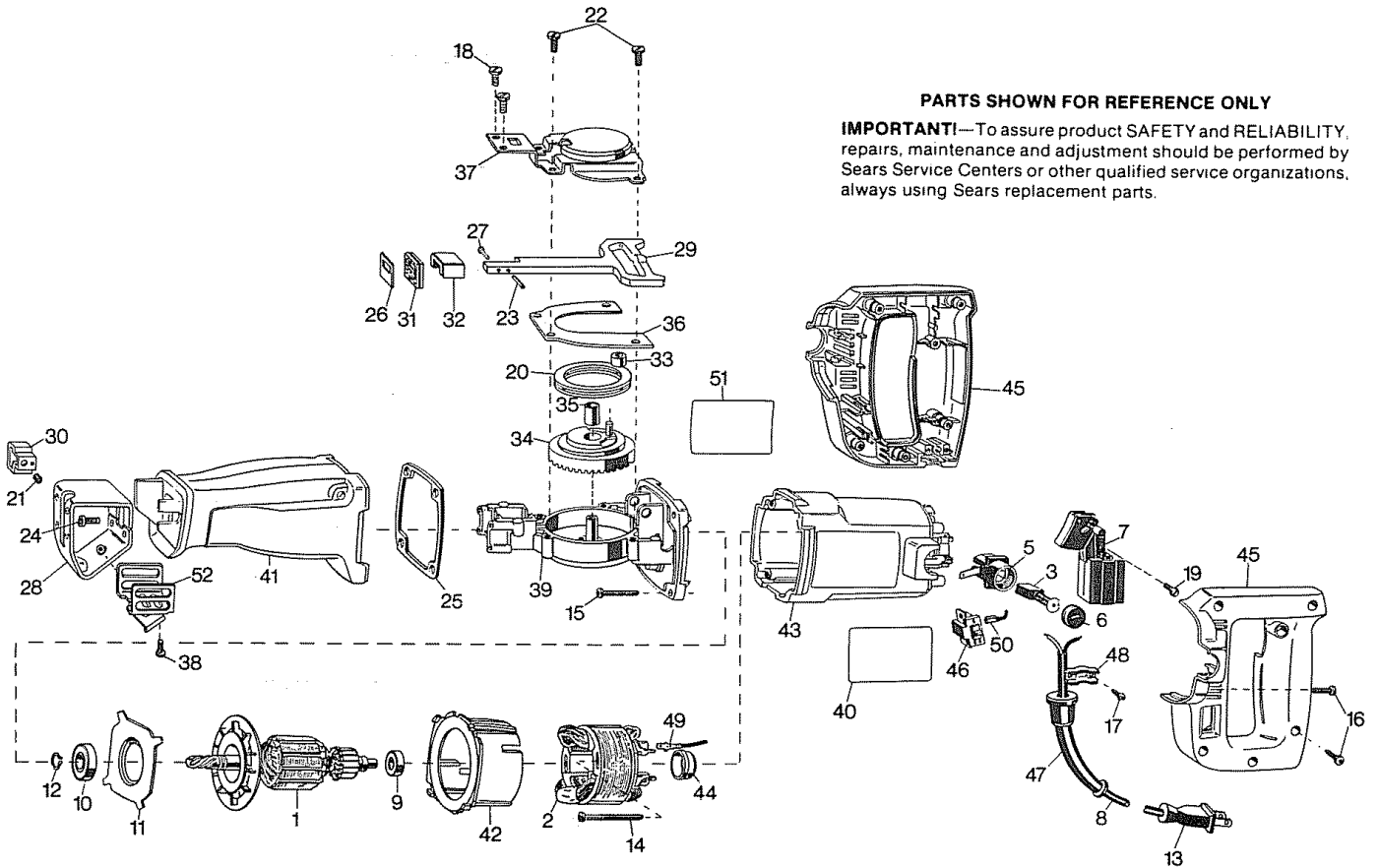

FOR PARTS LIST SEE PAGE 7

SEARS RECIPROCATING SAW - MODEL NUMBER 900.271221

The Model Number of your Reciprocating Saw will be found on the plate attached to the brush support.

PARTS LIST

(PARTS SHOWN FOR REFERENCE ONLY)

Item No.	Part No.	Description	Qty.	Item No.	Part No.	Description	Qty.
1	448716-00	Armature & Fan (6 Teeth) (Incl. 9,10,11,12)	1	24	142940-00	8-32x5/8" Self-Tapping Screw	4
2	448719-71	Field	1	25	146576-00	Gasket	1
3	450374-02	Brush	2	26	449778-00	Plate	1
5	448083-01	Brush Holder	2	27	146582-00	Pin	1
6	448084-01	Brush Cap	2	28	143463-01	Shoe	1
7	132504-01	Switch	1	29	679869-00	Shaft (Incl. 23,27)	1
8	448557-98	Cord & Plug (18-2 SJ)	1	30	679868-00	Blade Clamp (Incl. 21,23,27)	1
Ø 9	330003-04	Ball Bearing	1	31	448497-00	Seal	1
Ø 10	330003-09	Ball Bearing	1	32	450865-00	Bearing	1
11	448079-00	Bearing Plate	1	33	679404-00	Crank Bearing	1
12	696060-00	Retaining Ring	1	Ø 34	448503-14	Gear (55 Teeth) (Incl. 35)	1
13	234900-02	Attachment Plug	1	35	135531-00	Needle Bearing	1
14	448702-00	8-16x1-3/4" Thread Forming Screw	2	36	143462-00	Yoke Plate	1
15	978007-00	8-16x1-1/4" Thread Forming Screw	4	37	448489-03	Cover Plate	1
16	86964-00	8-16x23/32" Thread Forming Screw	9	38	99279-08	5/16"-18 Machine Screw	1
17	330013-03	6-19x5/8" Thread Forming Screw	2	39	449824-07	Gear Case	1
18	80440-00	8-32x1/2" Self- Tapping Screw	2	40	449577-00	Label	1
19	330013-02	Thread Forming Screw	1	41	448528-06	Housing Cover	1
20	144424-00	Thrust Ring	1	42	447786-00	Fan Baffle	1
21	450871-00	1/4-28x3/8" Set Screw	1	43	447799-02	Field Case	1
22	144457-00	10-24x5/8" Self-Tapping Screw	4	44	445217-01	Bearing Cup	1
23	144434-00	Roll Pin	1	45	448722-01	Handle and Cover	1
				Ø 46	144478-01	Two-Speed Switch	1
				47	330005-01	Cord Protector	1
				48	86634-00	Cord Clamp	1
				49	448172-00	Terminal	2
				50	136086-03	Terminal	2
				51	449851-01	Nameplate	1
				52	450698-01	Guard	1

Ø NOTES:

- 9 Seal faces Commutator, press flush with end of Shaft.
- 10 Seal faces Pinion; end of Shaft to Bearing; 1,048-1.052 inch
- 34 Units prior to date code 8848 with a screw holding gear, order 790549-00 for conversion kit.
- 46 Slide Switch Terminals and Diode must not touch Handle and Cover Housings (Item 45)

PARTS NOT SHOWN (Included with unit):

- 449817-00 Holder (For Hex Wrench) 1
- 99056-06 Hex Wrench (5/32") 1
- 450333-00 Kit Box 1
- 446901-07 Owners Manual 1

VOLTS	AMPS	SPM
120	6.0	1800/2400
AC Only		

EXTRA EQUIPMENT (Not supplied with unit):

- 448729 Connection Diagram
- 47492-01 Heavy Duty Grease (6 oz.)

LUBRICATION:

.32 oz. Heavy Duty Grease in Gear Case
Fill the depressed circular area of cover plate with ML 54-1.

SEE BACK FOR PARTS ORDERING INSTRUCTIONS.

SEARS

OWNERS
MANUAL

SERVICE

MODEL NO.
900.271221

HOW TO ORDER
REPAIR PARTS

CRAFTSMAN®

DUAL SPEED
RECIPROCATING SAW
DOUBLE INSULATED

Now that you have purchased your Reciprocating Saw, should a need ever exist for repair parts or service, simply contact any Sears Service Center and most Sears, Roebuck and Co. stores.
Be sure to provide all pertinent facts when you call or visit.

The model number of your Reciprocating Saw will be found on the plate attached to the brush support.

WHEN ORDERING REPAIR PARTS, ALWAYS GIVE THE FOLLOWING INFORMATION:

- | | |
|----------------|--------------------|
| • PART NUMBER | • PART DESCRIPTION |
| • MODEL NUMBER | • NAME OF ITEM |
| 900.271221 | Reciprocating Saw |

All parts listed may be ordered from any Sears Service Center and most Sears stores.

If the parts you need are not stocked locally, your order will be electronically transmitted to a Sears Repair Distribution Center for handling.

sold by SEARS, ROEBUCK AND CO., Chicago, IL 60684 U.S.A.