

CENTRAL PNEUMATIC®

OILLESS COMPRESSOR

Model 90168

SET UP AND OPERATING INSTRUCTIONS

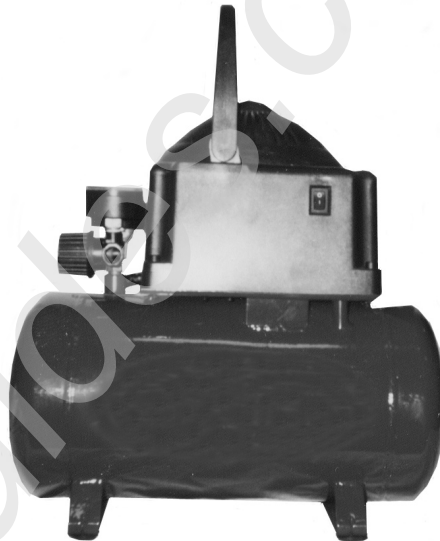

Distributed exclusively by Harbor Freight Tools®.

3491 Mission Oaks Blvd., Camarillo, CA 93011

Visit our website at: <http://www.harborfreight.com>



**Read this material before using this product.
Failure to do so can result in serious injury.
SAVE THIS MANUAL.**

Copyright© 2003 by Harbor Freight Tools®. All rights reserved. No portion of this manual or any artwork contained herein may be reproduced in any shape or form without the express written consent of Harbor Freight Tools. Diagrams within this manual may not be drawn proportionally. Due to continuing improvements, actual product may differ slightly from the product described herein. Tools required for assembly and service may not be included.

For technical questions or replacement parts, please call 1-800-444-3353.

Manual revised 08h

SAVE THIS MANUAL

Keep this manual for the safety warnings and precautions, assembly, operating, inspection, maintenance and cleaning procedures. Write the product's serial number in the back of the manual near the assembly diagram (or month and year of purchase if product has no number). Keep this manual and the receipt in a safe and dry place for future reference.

IMPORTANT SAFETY INFORMATION

In this manual, on the labeling, and all other information provided with this product:



This is the safety alert symbol. It is used to alert you to potential personal injury hazards. Obey all safety messages that follow this symbol to avoid possible injury or death.

DANGER

DANGER indicates a hazardous situation which, if not avoided, will result in death or serious injury.

WARNING

WARNING indicates a hazardous situation which, if not avoided, could result in death or serious injury.

CAUTION

CAUTION, used with the safety alert symbol, indicates a hazardous situation which, if not avoided, could result in minor or moderate injury.

NOTICE

NOTICE is used to address practices not related to personal injury.

CAUTION

CAUTION, without the safety alert symbol, is used to address practices not related to personal injury.

General Safety Warnings



WARNING Read all safety warnings and instructions. *Failure to follow the warnings and instructions may result in explosion, fire and/or serious injury.*
Save all warnings and instructions for future reference.

1. **Work area safety**
 - a. **Keep work area clean and well lit.** *Cluttered or dark areas invite accidents.*
 - b. **Do not operate compressors in explosive atmospheres, such as in the presence of flammable liquids, gases or dust.** *Compressors become hot which may ignite the dust or fumes.*
 - c. **Keep children and bystanders away while operating a compressor.** *Distractions can cause you to lose control.*
2. **Electrical safety**
 - a. **Compressor plugs must match the outlet. Never modify the plug in any way. Do not use any adapter plugs with grounded compressors.** *Unmodified plugs and matching outlets will reduce risk of electric shock.*
 - b. **Avoid body contact with grounded surfaces such as pipes, radiators,**

ranges and refrigerators. *There is an increased risk of electric shock if your body is grounded.*

- c. **Do not expose compressors to rain or wet conditions.** *Water entering a compressor will increase the risk of electric shock.*
- d. **Do not abuse the cord.** *Never use the cord for carrying, pulling or unplugging the compressor. Keep cord away from heat, oil, sharp edges or moving parts. Damaged or entangled cords increase the risk of electric shock.*
- e. **If operating a compressor in a damp location is unavoidable, use a Ground Fault Circuit Interrupter (GFCI) protected supply.** *Use of a GFCI reduces the risk of electric shock.*

RECOMMENDED MINIMUM WIRE GAUGE FOR EXTENSION CORDS (120 VOLT)				
NAMEPLATE AMPERES (at full load)	EXTENSION CORD LENGTH			
	25'	50'	100'	150'
0 – 6	18	16	16	14
6.1 – 10	18	16	14	12
10.1 – 12	16	16	14	12
12.1 – 16	14	12	Do not use.	

TABLE A

- f. **USE PROPER EXTENSION CORD.** *Make sure your extension cord is in good condition. When using an extension cord, be sure to use one heavy enough to carry the current your product will draw. An undersized cord will cause a drop in line voltage resulting in loss of power and overheating. Table A shows the correct size to use depending on cord length and nameplate ampere rating. If in*

doubt, use the next heavier gage. The smaller the gage number, the heavier the cord.

3. Personal safety

- a. **Stay alert, watch what you are doing and use common sense when operating this compressor.** *Do not use this compressor while you are tired or under the influence of drugs, alcohol or medication. A moment of inattention while operating compressors may result in serious personal injury.*
- b. **Use personal protective equipment. Always wear eye protection.** *Safety equipment such as dust mask, non-skid safety shoes, hard hat, or hearing protection used for appropriate conditions will reduce personal injuries.*
- c. **Prevent unintentional starting.** *Ensure the switch is in the off-position before connecting to power source or moving the compressor.*
- d. **Do not overreach. Keep proper footing and balance at all times.** *This enables better control of the compressor in unexpected situations.*
- e. **Dress properly. Do not wear loose clothing or jewelry. Keep your hair, clothing and gloves away from moving parts.** *Loose clothes, jewelry or long hair can be caught in moving parts.*
- f. **Only use safety equipment that has been approved by an appropriate standards agency.** *Unapproved safety equipment may not provide adequate protection. Eye protection must be ANSI-approved and breathing protection must be NIOSH-ap-*

proved for the specific hazards in the work area.

4. Compressor use and care

- a. **Do not force the compressor. Use the correct compressor for your application.** *The correct compressor will do the job better and safer at the rate for which it was designed.*
- b. **Do not use the compressor if the switch does not turn it on and off.** *Any compressor that cannot be controlled with the switch is dangerous and must be repaired.*
- c. **Disconnect the plug from the power source of the compressor before making any adjustments, changing accessories, or storing compressors.** *Such preventive safety measures reduce the risk of starting the compressor accidentally.*
- d. **Store idle compressors out of the reach of children and do not allow persons unfamiliar with the compressor or these instructions to operate it.** *Compressors are dangerous in the hands of untrained users.*
- e. **Maintain compressors. Check for misalignment or binding of moving parts, breakage of parts and any other condition that may affect the compressor's operation. If damaged, have the compressor repaired before use.** *Many accidents are caused by poorly maintained compressors.*
- f. **Use the compressor in accordance with these instructions, taking into account the working conditions and the work to be performed.** *Use of the compressor for operations different from those intended could result in a hazardous situation.*

5. Service

- a. **Have your compressor serviced by a qualified repair person using only identical replacement parts.** *This will ensure that the safety of the compressor is maintained.*

Air Compressor Safety Warnings

1. Risk of fire or explosion - do not spray flammable liquid in a confined area or towards a hot surface. Spray area must be well-ventilated. Do not smoke while spraying or spray where spark or flame is present. Arcing parts - keep compressor at least 20 feet away from explosive vapors, such as when spraying with a spray gun.
2. Risk of bursting - do not adjust regulator to result in output pressure greater than marked maximum pressure of attachment.
3. Risk of injury - do not direct air stream at body. To reduce the risk of electric shock, do not expose to rain. Store indoors.
4. Do not use to supply breathing air.
5. Do not direct air flow from the Compressor at people or animals.
6. Industrial applications must follow OSHA requirements.
7. Maintain labels and nameplates on the compressor. These carry important safety information. If unreadable or missing, contact Harbor Freight Compressors for a replacement.
8. Avoid unintentional starting. Prepare to begin work before turning on the compressor.

9. This product is not a toy. Keep it out of reach of children.
10. **WARNING:** The brass components of this product contain lead, a chemical known to the State of California to cause birth defects (or other reproductive harm). (California Health & Safety code § 25249.5, *et seq.*)
11. People with pacemakers should consult their physician(s) before use. Electromagnetic fields in close proximity to heart pacemaker could cause pacemaker interference or pacemaker failure. In addition, people with pacemakers should:
 - Avoid operating alone.
 - Do not use with power switch locked on.
 - Properly maintain and inspect to avoid electrical shock.
 - Any power cord must be properly grounded. Ground Fault Circuit Interrupter (GFCI) should also be implemented – it prevents sustained electrical shock.
12. Some dust created by power sanding, sawing, grinding, drilling, and other construction activities, contains chemicals known [to the State of California] to cause cancer, birth defects or other reproductive harm. Some examples of these chemicals are:
 - Lead from lead-based paints
 - Crystalline silica from bricks and cement or other masonry products
 - Arsenic and chromium from chemically treated lumberYour risk from these exposures varies, depending on how often you do this type of work. To reduce your exposure to these chemicals: work in a well ventilated area, and work with approved safety equipment, such as those dust masks that are specially designed to filter out microscopic particles. (California Health & Safety Code § 25249.5, *et seq.*)
13. **WARNING:** Handling the cord on this product will expose you to lead, a chemical known to the State of California to cause cancer, and birth defects or other reproductive harm. Wash hands after handling. (California Health & Safety Code § 25249.5, *et seq.*)
14. The warnings, precautions, and instructions discussed in this instruction manual cannot cover all possible conditions and situations that may occur. It must be understood by the operator that common sense and caution are factors which cannot be built into this product, but must be supplied by the operator.



SAVE THESE INSTRUCTIONS.

GROUNDING INSTRUCTIONS

⚠ WARNING TO PREVENT ELECTRIC SHOCK



AND DEATH FROM INCORRECT GROUNDING WIRE CONNECTION READ AND FOLLOW THESE INSTRUCTIONS:

Grounded Compressors: Compressors with Three Prong Plugs

1. In the event of a malfunction or breakdown, grounding provides a path of least resistance for electric current to reduce the risk of electric shock. This compressor is equipped with an electric cord having an equipment-grounding conductor and a grounding plug. The plug must be plugged into a matching outlet that is properly installed and grounded in accordance with all local codes and ordinances.
2. Do not modify the plug provided – if it will not fit the outlet, have the proper outlet installed by a qualified electrician.
3. Improper connection of the equipment-grounding conductor can result in a risk of electric shock. The conductor with insulation having an outer surface that is green with or without yellow stripes is the equipment-grounding conductor. If repair or replacement of the electric cord or plug is necessary, do not connect the equipment-grounding conductor to a live terminal.
4. Check with a qualified electrician or service personnel if the grounding

instructions are not completely understood, or if in doubt as to whether the compressor is properly grounded.

5. Use only 3-wire extension cords that have 3-prong grounding plugs and 3-pole receptacles that accept the compressor's plug.
6. Repair or replace damaged or worn cord immediately.

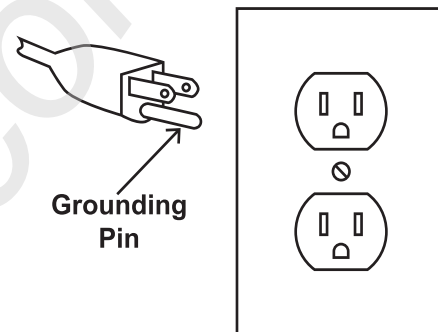

125 V~ 3-Prong Plug and Outlet
(for up to 125 V~ and up to 15 A)

7. This compressor is intended for use on a circuit that has an outlet that looks like the one illustrated above in **125 V~ 3-Prong Plug and Outlet**. The compressor has a grounding plug that looks like the plug illustrated above in **125 V~ 3-Prong Plug and Outlet**.
8. The outlet must be properly installed and grounded in accordance with all codes and ordinances.
9. Do not use an adapter to connect this compressor to a different outlet.

Double Insulated Compressors: Compressors with Two Prong Plugs

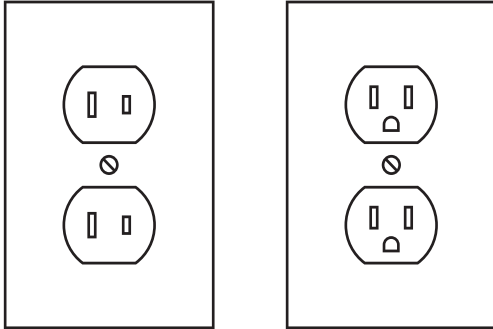

Outlets for 2-Prong Plug

1. To reduce the risk of electric shock, double insulated equipment has a polarized plug (one blade is wider than the other). This plug will fit in a polarized outlet only one way. If the plug does not fit fully in the outlet, reverse the plug. If it still does not fit, contact a qualified electrician to install the proper outlet. Do not change the plug in any way.
2. Double insulated compressors may be used in either of the 120 volt outlets shown in the preceding illustration. **(See Outlets for 2-Prong Plug.)**

SPECIFICATIONS

Electrical Requirements	120 V~ / 60 Hz / 210 W (Load) / 4.5 A (Start Up) / 6.25 A (Peak) Three Prong Plug
Air Tank Capacity	3 Gallons
Pressure Range	70-100 PSI
Air Flow Capacity	.5 CFM @ 90 PSI / .7 CFM @ 40 PSI
Accessories	25' Coil Air Hose / Air Chuck

UNPACKING

When unpacking, make sure that the item is intact and undamaged. If any parts are missing or broken, please call Harbor Freight Tools at the number shown on the cover of this manual as soon as possible.

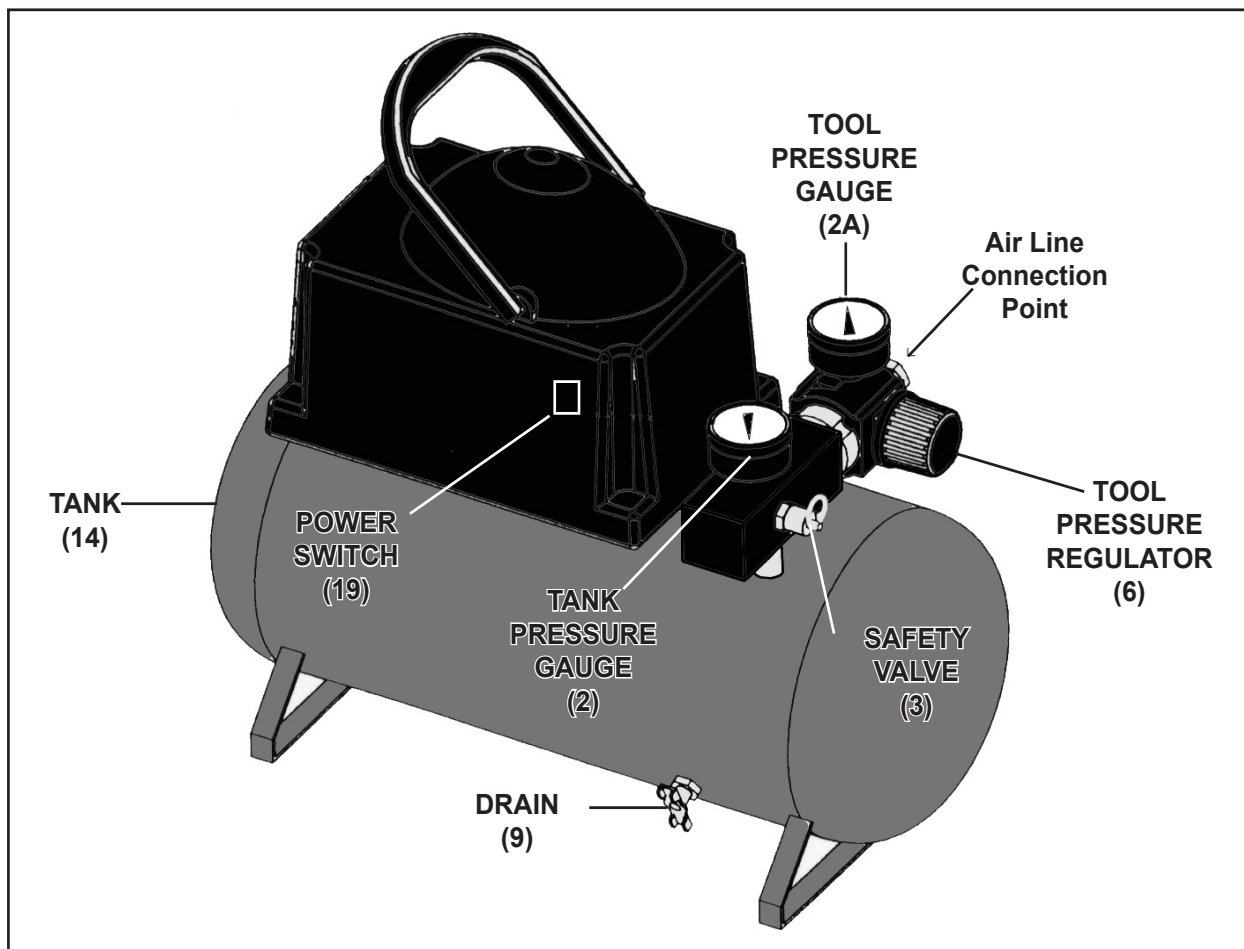

PRODUCT OVERVIEW



Read the **ENTIRE IMPORTANT SAFETY INFORMATION** section at the beginning of this manual including all text under subheadings therein before set up or use of this product.

WARNING

TO PREVENT SERIOUS INJURY

FROM ACCIDENTAL OPERATION:

Turn the Power Switch of the compressor to its "OFF" position and unplug the compressor from its electrical outlet before assembling or making any adjustments to the compressor.

Note: For additional information regarding the parts listed in the following pages, refer to the Assembly Diagram near the end of this manual.

Prior to using the Air Compressor, make sure to familiarize yourself with its basic features and methods of operation as described in this section:

1. **Power Switch (19):** The Power Switch turns the Air Compressor ON and OFF. When the Power Switch is in its ON position it allows the Air Compressor to automatically start up or shut down depending on the level of compressed air in the Air Compressor's Tank (14).
2. **Safety Valve (3):** If the Air Compressor does *not* automatically shut down when the air pressure reaches the

factory preset level, the Safety Valve will automatically pop open to prevent over pressurization in the Tank (14). To operate the Safety Valve manually, pull the ring on the Safety Valve to relieve air pressure in the Tank.

3. **Tank Pressure Gauge (2):** The Tank Pressure Gauge measures the air pressure stored in the Tank (14), and is *not* adjustable by the operator.
4. **Tool Pressure Gauge (2A):** The Tool Pressure Gauge measures the air pressure being supplied to the tool being used.
5. **Tool Pressure Regulator (6):** The Tool Pressure Regulator allows you to adjust the air pressure (0 to 120 PSI) being supplied to the tool being used. Turn the Tool Pressure Regulator *clockwise* to *increase* the air pressure to the tool, and *counterclockwise* to *decrease* the air pressure.

OPERATING INSTRUCTIONS



Read the ENTIRE IMPORTANT SAFETY INFORMATION section at the beginning of this manual including all text under subheadings therein before set up or use of this product.

1. Close the Drain (9) completely.
2. Turn the Tool Pressure Regulator (6) *counterclockwise* until it is fully closed.
3. Pull the ring on the Safety Valve (3) to check that it operates properly.
4. Attach the Air Hose (20) to the air outlet on the Regulator (6). Connect the other end of the air hose to the air inlet of the tool. Other components, such as a connector and quick coupler, will make operation more efficient, but are not required.
5. Plug the Power Cord/Plug (7) into the nearest 120 volt, grounded, electrical outlet.
6. Turn the Power Switch (19) to its **AUTO** or **I** position.
7. Observe the Tank Pressure Gauge (2), and allow the air pressure in the Tank (14) to build up to **70 PSI**.
8. Observe the Tool Pressure Gauge (2A), while turning the Tool Pressure Regulator *clockwise* to increase pressure up to the desired level.
9. **The Air Compressor is now ready to use.** When finished using the Air Compressor, turn the Power Switch (19) to its **OFF** or **O** position. Then, unplug the Air Compressor from its electrical outlet.
10. Turn the Tool Pressure Regulator (6) *counterclockwise* until it is fully closed.
11. Pull the ring on the Safety Valve (3) to relieve all remaining air pressure in the Tank.
12. Activate the tool in a safe manner to release air pressure from the air hose. Then, disconnect the air hose from the tool, and store the compressor in a safe, dry location.

Note: If inflating tires or other objects, connect the Air Hose (20) to the Inflation Chuck (21). Do not overinflate any object.

WARNING! Do not exceed the tool's maximum air pressure.

MAINTENANCE AND SERVICING



Procedures not specifically explained in this manual must be performed only by a qualified technician.

⚠️ WARNING TO PREVENT SERIOUS INJURY

FROM ACCIDENTAL OPERATION:

Turn the Power Switch of the compressor to its "OFF" position and unplug the compressor from its electrical outlet before performing any inspection, maintenance, or cleaning procedures.

TO PREVENT SERIOUS INJURY FROM COMPRESSOR FAILURE:

Do not use damaged equipment. If abnormal noise or vibration occurs, have the problem corrected before further use.

1. **BEFORE EACH USE**, inspect the general condition of the Air Compressor. Check for loose screws, misalignment or binding of moving parts, damaged electrical wiring, Tank, air hoses/accessories (not included), and any other condition that may affect its safe operation.
2. **AT END OF EACH WORKDAY:** Condensation will accumulate inside the Tank (14). To prevent corrosion inside the Tank, the moisture should be drained at the end of each workday. To drain the moisture, Pull the ring on the Safety Valve (3) to relieve all remaining air pressure in the Tank.

Open the Drain (9) on the bottom of the Tank, and tilt the Tank to allow the moisture to drain. Then, make sure to fully close the Drain.

3. **TO CLEAN:** Use a clean cloth and mild detergent to clean the body of the Air Compressor. Do not use solvents. Do not immerse any part of the Air Compressor in liquid.
4. **⚠️ WARNING!** If the supply cord of this power tool is damaged, it must be replaced only by a qualified service technician.

PLEASE READ THE FOLLOWING CAREFULLY

THE MANUFACTURER AND/OR DISTRIBUTOR HAS PROVIDED THE PARTS LIST AND ASSEMBLY DIAGRAM IN THIS MANUAL AS A REFERENCE TOOL ONLY. NEITHER THE MANUFACTURER OR DISTRIBUTOR MAKES ANY REPRESENTATION OR WARRANTY OF ANY KIND TO THE BUYER THAT HE OR SHE IS QUALIFIED TO MAKE ANY REPAIRS TO THE PRODUCT, OR THAT HE OR SHE IS QUALIFIED TO REPLACE ANY PARTS OF THE PRODUCT. IN FACT, THE MANUFACTURER AND/OR DISTRIBUTOR EXPRESSLY STATES THAT ALL REPAIRS AND PARTS REPLACEMENTS SHOULD BE UNDERTAKEN BY CERTIFIED AND LICENSED TECHNICIANS, AND NOT BY THE BUYER. THE BUYER ASSUMES ALL RISK AND LIABILITY ARISING OUT OF HIS OR HER REPAIRS TO THE ORIGINAL PRODUCT OR REPLACEMENT PARTS THERETO, OR ARISING OUT OF HIS OR HER INSTALLATION OF REPLACEMENT PARTS THERETO.

PARTS LIST

Part	Description	Qty.
1	Shroud w/Handle	1
2	Tank Pressure Gauge	1
2A	Tool Pressure Gauge	1
3	Safety Valve	1
4	Air Line Outlet	1
5	Connector	2
6	Tool Pressure Regulator	1
7	Power Cord/Plug	1
8	Fan	1
9	Drain	1
10	Rubber Foot	4

PARTS LIST

Part	Description	Qty.
11	Circuit Board	1
12	Pressure Switch	1
13	Pump Assembly	1
14	Tank	1
15	Connector (1/8"-27 NPT)	2
16	Connection Nut	2
17	Copper Vent Tube	1
18	Screw	8
19	Power Switch	1
20	25' Air Hose (Not Shown)	1
21	Inflation Chuck (Not Shown)	1

ASSEMBLY DIAGRAM

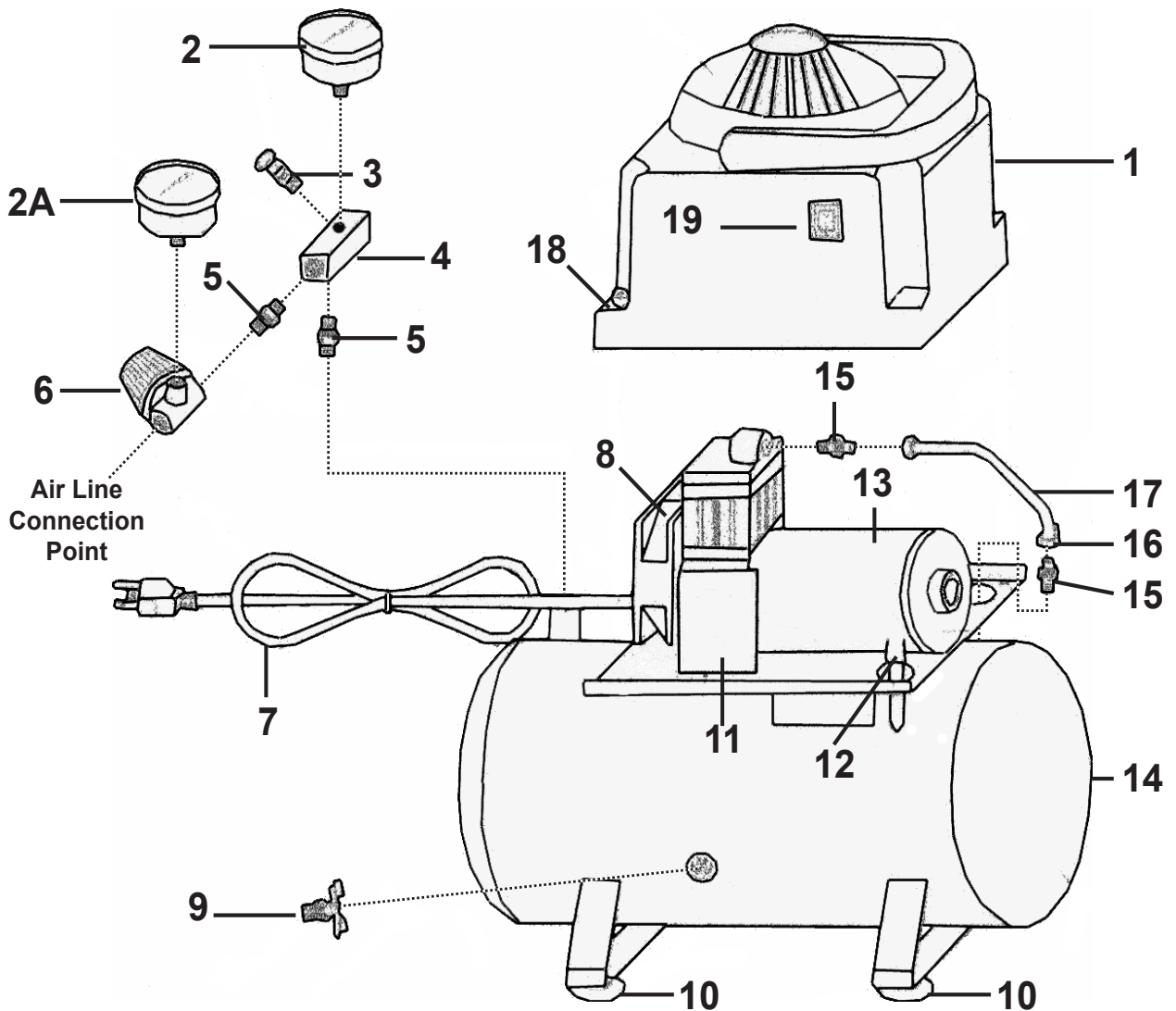

Parts 20 and 21 - Air Hose and Inflation Chuck - not shown.

Record Product's Serial Number Here: _____

Note: If product has no serial number, record month and year of purchase instead.

Note: Some parts are listed and shown for illustration purposes only, and are not available individually as replacement parts.

LIMITED 1 YEAR / 90 DAY WARRANTY

Harbor Freight Tools Co. makes every effort to assure that its products meet high quality and durability standards, and warrants to the original purchaser that for a period of one year from date of purchase that the tank is free of defects in materials and workmanship (90 days if used by a professional contractor or if used as rental equipment). Harbor Freight Tools also warrants to the original purchaser, for a period of ninety days from date of purchase, that all other parts and components of the product are free from defects in materials and workmanship. This warranty does not apply to damage due directly or indirectly to misuse, abuse, negligence or accidents, repairs or alterations outside our facilities, normal wear and tear, or to lack of maintenance. We shall in no event be liable for death, injuries to persons or property, or for incidental, contingent, special or consequential damages arising from the use of our product. Some states do not allow the exclusion or limitation of incidental or consequential damages, so the above limitation of exclusion may not apply to you. THIS WARRANTY IS EXPRESSLY IN LIEU OF ALL OTHER WARRANTIES, EXPRESS OR IMPLIED, INCLUDING THE WARRANTIES OF MERCHANTABILITY AND FITNESS.

To take advantage of this warranty, the product or part must be returned to us with transportation charges prepaid. Proof of purchase date and an explanation of the complaint must accompany the merchandise. If our inspection verifies the defect, we will either repair or replace the product at our election or we may elect to refund the purchase price if we cannot readily and quickly provide you with a replacement. We will return repaired products at our expense, but if we determine there is no defect, or that the defect resulted from causes not within the scope of our warranty, then you must bear the cost of returning the product.

This warranty gives you specific legal rights and you may also have other rights which vary from state to state.

3491 Mission Oaks Blvd. • PO Box 6009 • Camarillo, CA 93011 • (800) 444-3353