

6" Variable Speed Bench Jointer (Model 37-070)



PART NO. 901609 (013)
Copyright © 2001 Delta Machinery



To learn more about DELTA MACHINERY
visit our website at: www.deltamachinery.com.

For Parts, Service, Warranty or other Assistance,

please call **1-800-223-7278** (In Canada call **1-800-463-3582**).

ESPAÑOL: PÁGINA 21

SAFETY RULES

Woodworking can be dangerous if safe and proper operating procedures are not followed. As with all machinery, there are certain hazards involved with the operation of the product. Using the machine with respect and caution will considerably lessen the possibility of personal injury. However, if normal safety precautions are overlooked or ignored, personal injury to the operator may result. Safety equipment such as guards, push sticks, hold-downs, featherboards, goggles, dust masks and hearing protection can reduce your potential for injury. But even the best guard won't make up for poor judgment, carelessness or inattention. Always use common sense and exercise caution in the workshop. If a procedure feels dangerous, don't try it. Figure out an alternative procedure that feels safer. **REMEMBER:** Your personal safety is your responsibility.

This machine was designed for certain applications only. Delta Machinery strongly recommends that this machine not be modified and/or used for any application other than that for which it was designed. If you have any questions relative to a particular application, **DO NOT** use the machine until you have first contacted Delta to determine if it can or should be performed on the product.

**Technical Service Manager
Delta Machinery
4825 Highway 45 North
Jackson, TN 38305**

(IN CANADA: 505 SOUTHGATE DRIVE, GUELPH, ONTARIO N1H 6M7)



WARNING: FAILURE TO FOLLOW THESE RULES MAY RESULT IN SERIOUS PERSONAL INJURY

1. FOR YOUR OWN SAFETY, READ INSTRUCTION MANUAL BEFORE OPERATING THE TOOL. Learn the tool's application and limitations as well as the specific hazards peculiar to it.

2. KEEP GUARDS IN PLACE and in working order.

3. ALWAYS WEAR EYE PROTECTION.

4. REMOVE ADJUSTING KEYS AND WRENCHES. Form habit of checking to see that keys and adjusting wrenches are removed from tool before turning it "on".

5. KEEP WORK AREA CLEAN. Cluttered areas and benches invite accidents.

6. DON'T USE IN DANGEROUS ENVIRONMENT. Don't use power tools in damp or wet locations, or expose them to rain. Keep work area well-lighted.

7. KEEP CHILDREN AND VISITORS AWAY. All children and visitors should be kept a safe distance from work area.

8. MAKE WORKSHOP CHILDPROOF – with padlocks, master switches, or by removing starter keys.

9. DON'T FORCE TOOL. It will do the job better and be safer at the rate for which it was designed.

10. USE RIGHT TOOL. Don't force tool or attachment to do a job for which it was not designed.

11. WEAR PROPER APPAREL. No loose clothing, gloves, neckties, rings, bracelets, or other jewelry to get caught in moving parts. Non-slip footwear is recommended. Wear protective hair covering to contain long hair.

12. ALWAYS USE SAFETY GLASSES. Wear safety glasses. Everyday eyeglasses only have impact resistant lenses; they are not safety glasses. Also use face or dust mask if cutting operation is dusty. These safety glasses must conform to ANSI Z87.1 requirements. Note: Approved glasses have Z87 printed or stamped on them.

13. SECURE WORK. Use clamps or a vise to hold work when practical. It's safer than using your hand and frees both hands to operate tool.

14. DON'T OVERREACH. Keep proper footing and balance at all times.

15. MAINTAIN TOOLS IN TOP CONDITION. Keep tools sharp and clean for best and safest performance. Follow instructions for lubricating and changing accessories.

16. DISCONNECT TOOLS before servicing and when changing accessories such as blades, bits, cutters, etc.

17. USE RECOMMENDED ACCESSORIES. The use of accessories and attachments not recommended by Delta may cause hazards or risk of injury to persons.

18. REDUCE THE RISK OF UNINTENTIONAL STARTING. Make sure switch is in "OFF" position before plugging in power cord.

19. NEVER STAND ON TOOL. Serious injury could occur if the tool is tipped or if the cutting tool is accidentally contacted.

20. CHECK DAMAGED PARTS. Before further use of the tool, a guard or other part that is damaged should be carefully checked to ensure that it will operate properly and perform its intended function – check for alignment of moving parts, binding of moving parts, breakage of parts, mounting, and any other conditions that may affect its operation. A guard or other part that is damaged should be properly repaired or replaced.

21. DIRECTION OF FEED. Feed work into a blade or cutter against the direction of rotation of the blade or cutter only.

22. NEVER LEAVE TOOL RUNNING UNATTENDED. TURN POWER OFF. Don't leave tool until it comes to a complete stop.

23. DRUGS, ALCOHOL, MEDICATION. Do not operate tool while under the influence of drugs, alcohol or any medication.

24. MAKE SURE TOOL IS DISCONNECTED FROM POWER SUPPLY while motor is being mounted, connected or re-connected.

25. THE DUST GENERATED by certain woods and wood products can be injurious to your health. Always operate machinery in well ventilated areas and provide for proper dust removal. Use wood dust collection systems whenever possible.

26. ⚠ WARNING: SOME DUST CREATED BY POWER SANDING, SAWING, GRINDING, DRILLING, AND OTHER CONSTRUCTION ACTIVITIES contains chemicals known to cause cancer, birth defects or other reproductive harm. Some examples of these chemicals are:

- lead from lead-based paints,
- crystalline silica from bricks and cement and other masonry products, and
- arsenic and chromium from chemically-treated lumber.

Your risk from these exposures varies, depending on how often you do this type of work. To reduce your exposure to these chemicals: work in a well ventilated area, and work with approved safety equipment, such as those dust masks that are specially designed to filter out microscopic particles.

SAVE THESE INSTRUCTIONS. Refer to them often and use them to instruct others.

ADDITIONAL SAFETY RULES FOR JOINTERS

1. **DO NOT OPERATE** the tool until it is completely assembled and installed according to the instructions.
2. **IF YOU ARE NOT** thoroughly familiar with the operation of jointers, obtain advice from your supervisor, instructor or other qualified person.
3. **KEEP** cutterhead sharp and free of all rust and pitch.
4. **BEFORE** starting machine, check cutterhead and drive guards to be sure they are in place and in proper operating condition.
5. **ALWAYS** make sure exposed cutterhead behind the fence is guarded, especially when jointing near the edge.
6. **NEVER** perform jointing or planing operations with the cutterhead guard or drive guard removed.
7. **MAKE CERTAIN** the infeed table is tightened before starting the machine.
8. **NEVER** start the jointer with the workpiece contacting the cutterhead.
9. **ALWAYS** hold the workpiece firmly against the tables and fence.
10. **NEVER** perform any operation “free-hand” which means using your hands to support or guide the workpiece. **ALWAYS** use the fence to position and guide the work.
11. **AVOID** awkward operations and hand positions where a sudden slip could cause your hand to move into the cutterhead.
12. **ALWAYS** use hold-down/push blocks for jointing material less than 3 inches in height or planing material thinner than 3 inches.
13. **DO NOT** perform jointing operations on material shorter than 10 inches, narrower than 3/4 inch or less than 1/2 inch thick.
14. **DO NOT** perform planing operations on material shorter than 10 inches, narrower than 3/4 inch, wider than 6 inches or less than 1/2 inch thick.
15. **NEVER** make jointing or planing cuts deeper than 1/8 inch. On cuts more than 1-1/2 inches wide, adjust depth of cut to 1/16 inch or less to avoid overloading machine and to minimize chance of kick-back (work thrown back toward you).
16. **MAINTAIN** the proper relationship of infeed and outfeed table surfaces and cutterhead knife path.
17. **SUPPORT** the workpiece adequately at all times during operation; maintain control of the work at all times.
18. **DO NOT** back the workpiece toward the infeed table.
19. **DO NOT** attempt to perform an abnormal or little-used operation without study and the use of adequate hold-down/push blocks, jigs, fixtures, stops, etc.
20. **SHUT OFF** power before servicing or adjusting tool and in the event of a power failure.
21. **DISCONNECT** tool from power source and clean the machine before leaving it.
22. **MAKE SURE** the work area is clean before leaving the machine.
23. **SHOULD** any part of your tool be missing, damaged, or fail in any way, or any electrical component fail to perform properly, shut off switch and remove plug from power supply outlet. Replace missing, damaged or failed parts before resuming operation.
24. **THE USE** of attachments and accessories not recommended by Delta may result in the risk of injuries.
25. **IMPORTANT: When the tool is not in use, the switch should be locked in the “OFF” position to prevent unauthorized use.**
26. **ADDITIONAL INFORMATION** regarding the safe and proper operation of this product is available from the National Safety Council, 1121 Spring Lake Drive, Itasca, IL 60143-3201 in the Accident Prevention Manual for Industrial Operation and also in the Safety Data Sheets provided by the NSC. Please also refer to the American National Standard Institute ANSI 01.1 Safety Requirements for Woodworking Machinery and the U.S. Department of Labor OSHA 1910.213 Regulations.

EXTENSION CORDS

Use proper extension cords. Make sure your extension cord is in good condition and is a 3-wire extension cord which has a 3-prong grounding type plug and a 3-hole receptacle which will accept the tool's plug. When using an extension cord, be sure to use one heavy enough to carry the current of the tool. An undersized cord will cause a drop in line voltage, resulting in loss of power and overheating. Fig. DD, shows the correct gauge to use depending on the cord length. If in doubt, use the next heavier gauge. The smaller the gauge number, the heavier the cord.

| MINIMUM GAUGE EXTENSION CORD | | | |
|--|-------|---|-------------------------|
| RECOMMENDED SIZES FOR USE WITH STATIONARY ELECTRIC TOOLS | | | |
| Ampere Rating | Volts | Total Length of Cord in Feet | Gauge of Extension Cord |
| 0-6 | 120 | up to 25 | 18 AWG |
| 0-6 | 120 | 25-50 | 16 AWG |
| 0-6 | 120 | 50-100 | 16 AWG |
| 0-6 | 120 | 100-150 | 14 AWG |
| 6-10 | 120 | up to 25 | 18 AWG |
| 6-10 | 120 | 25-50 | 16 AWG |
| 6-10 | 120 | 50-100 | 14 AWG |
| 6-10 | 120 | 100-150 | 12 AWG |
| 10-12 | 120 | up to 25 | 16 AWG |
| 10-12 | 120 | 25-50 | 16 AWG |
| 10-12 | 120 | 50-100 | 14 AWG |
| 10-12 | 120 | 100-150 | 12 AWG |
| 12-16 | 120 | up to 25 | 14 AWG |
| 12-16 | 120 | 25-50 | 12 AWG |
| 12-16 | 120 | <i>GREATER THAN 50 FEET NOT RECOMMENDED</i> | |

Fig. DD

| MINIMUM GAUGE EXTENSION CORD | | | |
|--|-------|--|-------------------------|
| RECOMMENDED SIZES FOR USE WITH STATIONARY ELECTRIC TOOLS | | | |
| Ampere Rating | Volts | Total Length of Cord in Feet | Gauge of Extension Cord |
| 0-6 | 240 | up to 50 | 18 AWG |
| 0-6 | 240 | 50-100 | 16 AWG |
| 0-6 | 240 | 100-200 | 16 AWG |
| 0-6 | 240 | 200-300 | 14 AWG |
| 6-10 | 240 | up to 50 | 18 AWG |
| 6-10 | 240 | 50-100 | 16 AWG |
| 6-10 | 240 | 100-200 | 14 AWG |
| 6-10 | 240 | 200-300 | 12 AWG |
| 10-12 | 240 | up to 50 | 16 AWG |
| 10-12 | 240 | 50-100 | 16 AWG |
| 10-12 | 240 | 100-200 | 14 AWG |
| 10-12 | 240 | 200-300 | 12 AWG |
| 12-16 | 240 | up to 50 | 14 AWG |
| 12-16 | 240 | 50-100 | 12 AWG |
| 12-16 | 240 | <i>GREATER THAN 100 FEET NOT RECOMMENDED</i> | |

Fig. DD

OPERATING INSTRUCTIONS

FOREWORD

Delta Model 37-070 is a 6" Variable Speed Bench Jointer with designed cutting capacity of 6" (152mm) width and 1/8" (3mm) depth. Unit includes; 10 amp, 120 volt motor with variable speed range from 6000 to 11,000 rpm and cutting speed range from 12,000 to 22,000 cpm, dust chute, center-mounted fence, two-knife cutterhead, cutterhead guard and lock, wrenches and push blocks.

UNPACKING AND CLEANING

Carefully unpack the tool and all loose items from the shipping container(s). Remove the protective coating from all unpainted surfaces. This coating may be removed with a soft cloth moistened with kerosene (do not use acetone, gasoline or lacquer thinner for this purpose). After cleaning, cover the unpainted surfaces with a good quality household floor paste wax.

DEFINITIONS OF JOINTING AND PLANING OPERATIONS

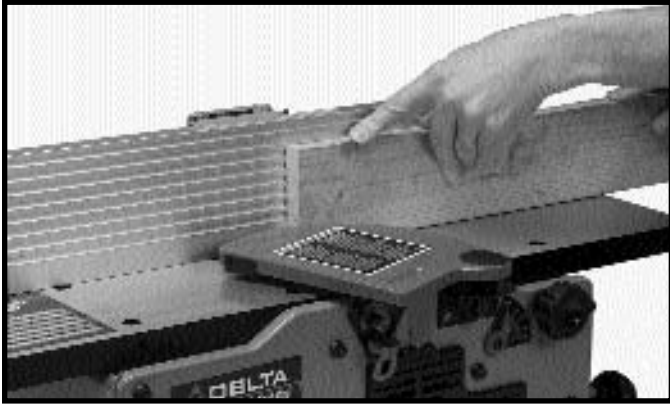

Fig. 2

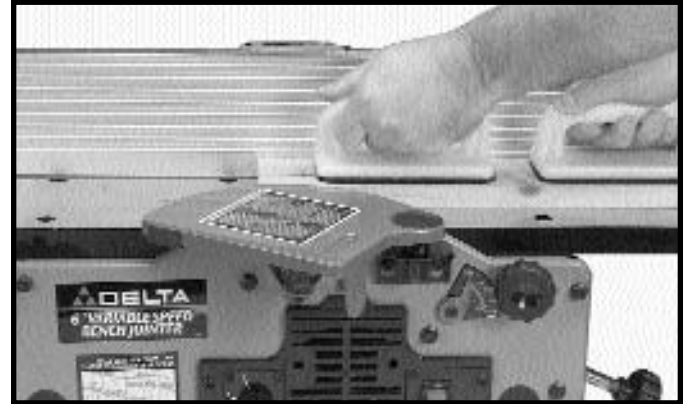

Fig. 3

1. **JOINTING OPERATIONS** – Jointing cuts or edge jointing are made to square an edge of a workpiece. The workpiece is positioned on the jointer with the narrow edge of the workpiece on the infeed table and the major flat surface of the workpiece against the fence, as shown in Fig. 2. The workpiece is moved from the infeed table, across the cutterhead to the outfeed table.

2. **PLANING OPERATIONS** – Planing or surfacing are identical to the jointing operation except for the position of the workpiece. For planing, the major flat surface of the workpiece is placed on the infeed table of the jointer with the narrow edge of the workpiece against the fence, as shown in Fig. 3. The workpiece is moved from the infeed table, across the cutterhead to the outfeed table. Use push blocks when performing planing operations whenever possible.

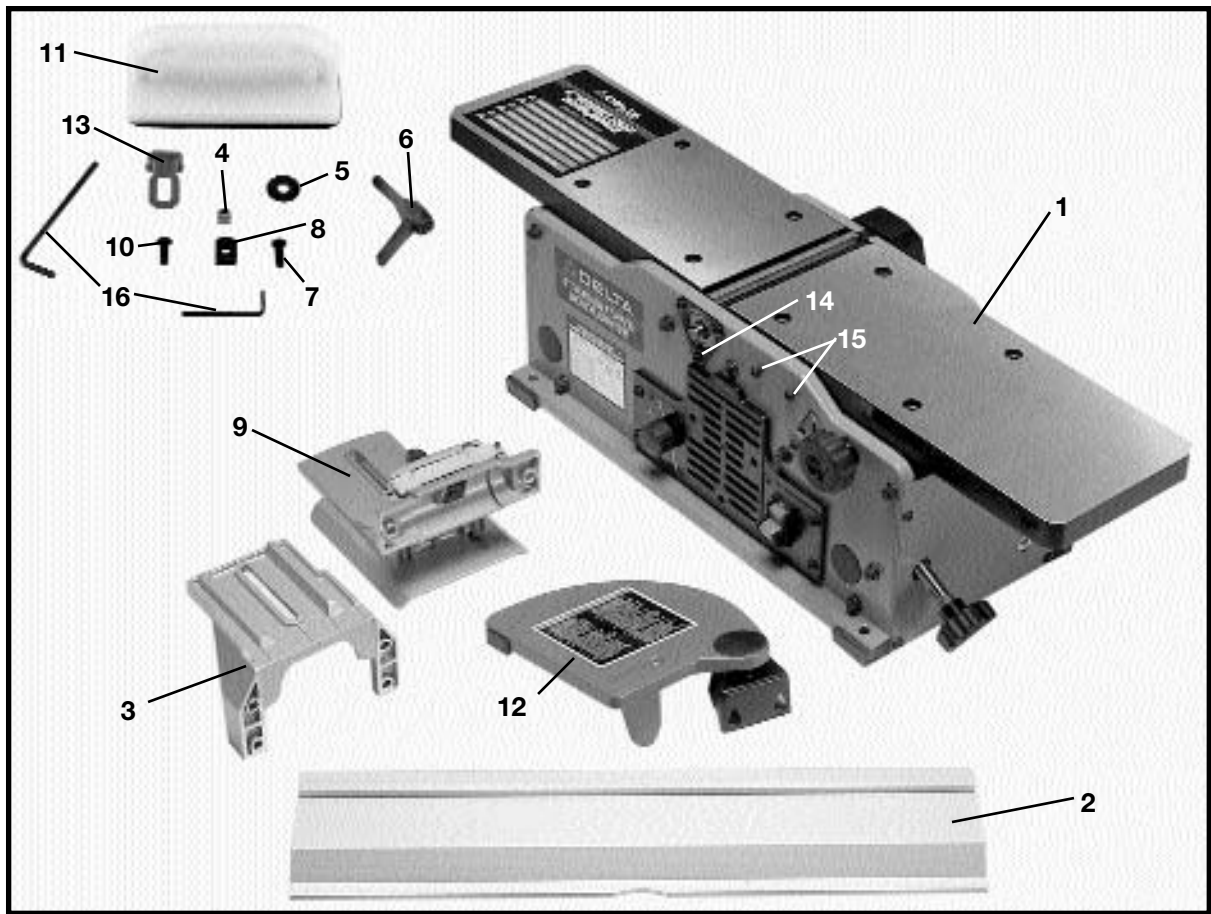

Fig. 4

- 1 - Jointer
- 2 - Fence
- 3 - Fence Sliding Bracket
- 4 - Special Nut (for assembling Fence Sliding Bracket to Fence Mounting Bracket)
- 5 - Flat Washer (for assembling Fence Sliding Bracket to Fence Mounting Bracket)
- 6 - Spring Loaded Lock Handle (for assembling Fence Sliding Bracket to Fence Mounting Bracket)
- 7 - 5/8" long Socket Button Head Screw (for assembling Fence to Fence Sliding Bracket) -(2)
- 8 - T-Nut (for assembling Fence to Fence Sliding Bracket) -(2)
- 9 - Fence Mounting Bracket
- 10 - 5/8" long Socket Button Head Screw (for assembling Fence Mounting Bracket to Jointer Base)- (4)
- 11 - Push Blocks - (2)
- 12 - Cutterhead Guard
- 13 - Cutterhead Lock
- 14 - 7/16" long Socket Button Head Screw (for assembling Cutterhead Lock to Jointer Base)
- 15 - 7/16" long Socket Button Head Screw (for assembling Cutterhead Guard to Jointer Base) - (2)
- 16 - Allen Wrenches - (2)

ASSEMBLY INSTRUCTIONS

 **WARNING: FOR YOUR OWN SAFETY, DO NOT CONNECT THE TOOL TO THE POWER SOURCE UNTIL THE MACHINE IS COMPLETELY ASSEMBLED AND YOU HAVE READ AND UNDERSTAND THE ENTIRE OWNERS MANUAL.**

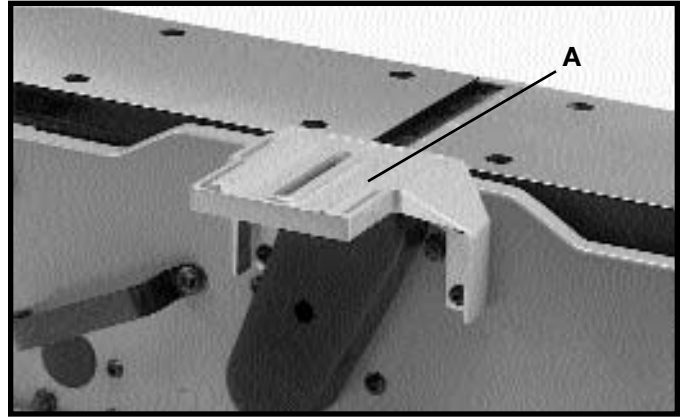

Fig. 5

ASSEMBLING FENCE

1. Assemble the fence mounting bracket (A) Fig. 5, to the jointer base using the four 5/8" long socket button head screws (B) Fig. 6.

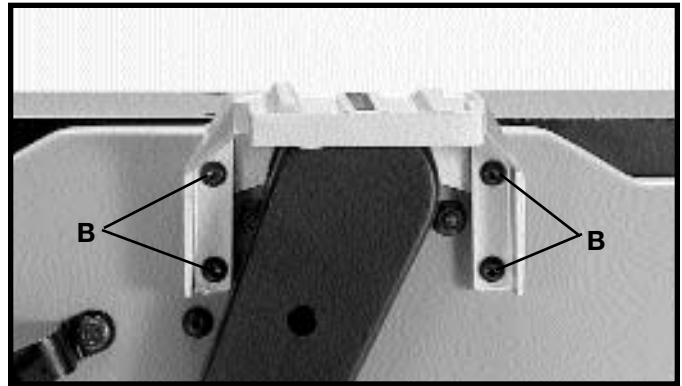

Fig. 6

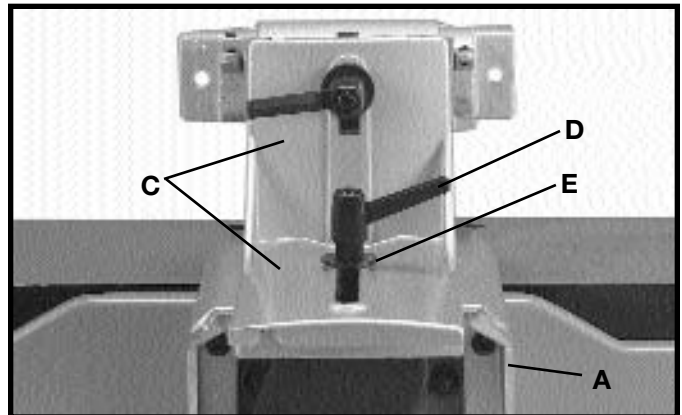

Fig. 7

2. Assemble the fence sliding bracket (C) Fig. 7, to mounting bracket (A) using the lockhandle (D), flat washer (E) and special nut (F) Fig. 8.

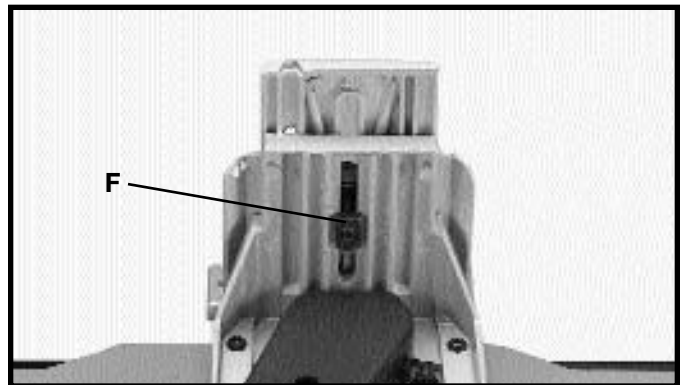

Fig. 8

3. Assemble 5/8" long socket button head screw (G) Fig. 9, to fence tilting bracket (H) and thread T-nut (J) onto threaded end of screw (G) as shown. **DO NOT COMPLETELY TIGHTEN SCREW (G) AT THIS TIME.** Assemble screw and T-nut to opposite end of tilting bracket in the same manner.

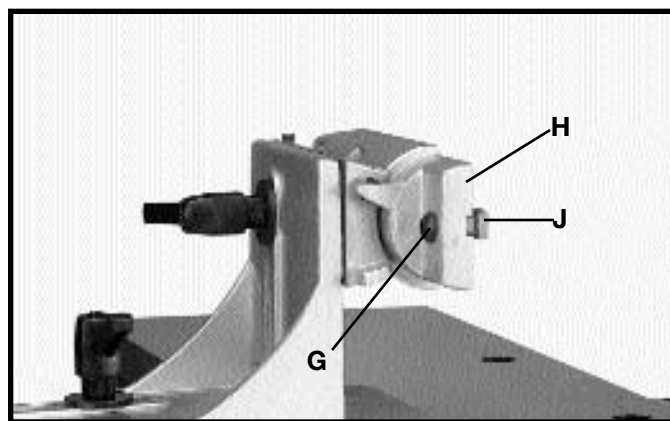

Fig. 9

4. Slide groove of fence (L) Fig. 10, over T-nuts (J) as shown.

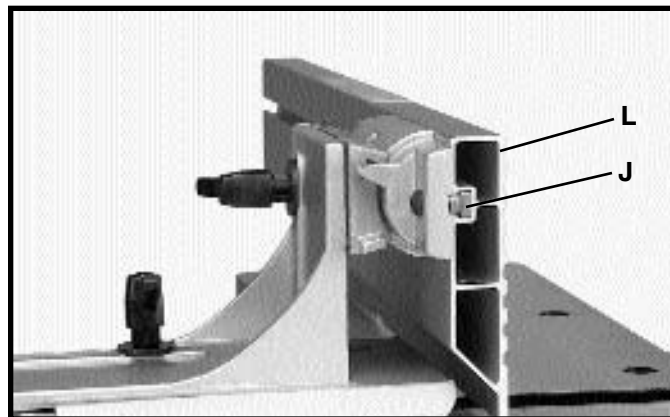

Fig. 10

5. Position fence (L) Fig. 11, so that rounded section (M) on bottom of fence is over cutterhead opening as shown.

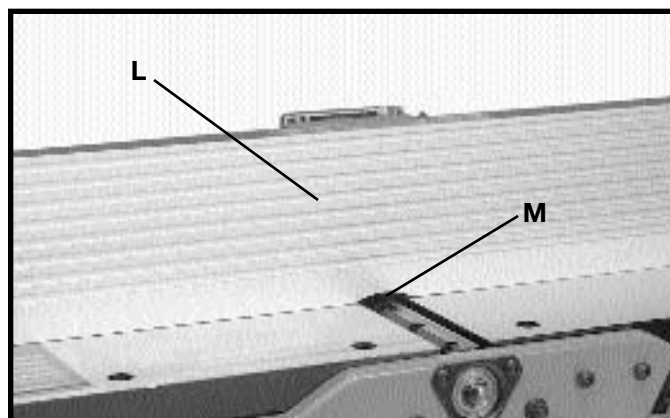

Fig. 11

6. Tighten two screws (G) Fig. 12.



Fig. 12

ASSEMBLING CUTTERHEAD GUARD

1. Thread the two 7/16" long socket button head screws (A) Fig. 13, into the two threaded holes in front side of jointer base. **DO NOT COMPLETELY TIGHTEN SCREWS (A) AT THIS TIME.**

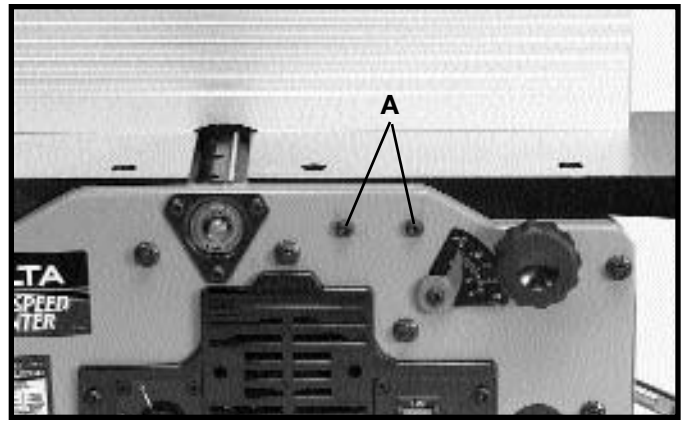

Fig. 13

2. Assemble guard mounting bracket (B) Fig. 14, to the two screws (A) as shown, and tighten the two screws (A).

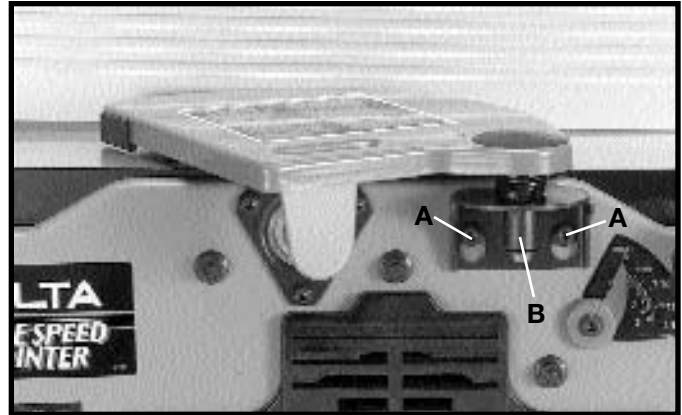

Fig. 14

ASSEMBLING CUTTERHEAD LOCK

1. Assemble cutterhead lock (A) Fig. 15, to the front side of the jointer base, using the 7/16" long socket button head screw (B). **NOTE: THE CUTTERHEAD LOCK (A) IS TO BE ENGAGED WITH THE CUTTERHEAD SHAFT AS SHOWN IN FIG. 15. ONLY WHEN SETTING KNIVES. ALL OTHER TIMES THE CUTTERHEAD LOCK (A) SHOULD BE DISENGAGED FROM THE CUTTERHEAD, AS SHOWN IN FIG. 16.**

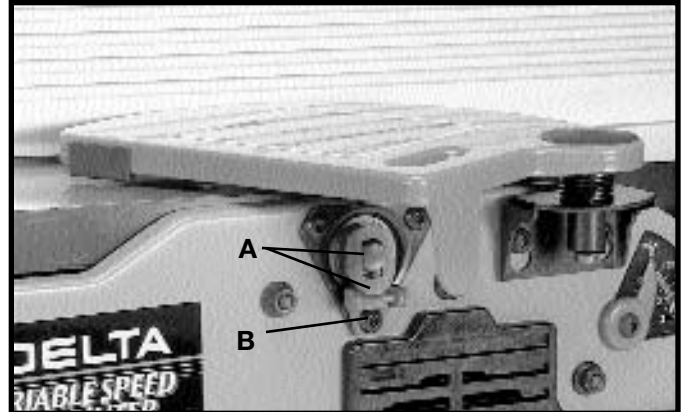

Fig. 15

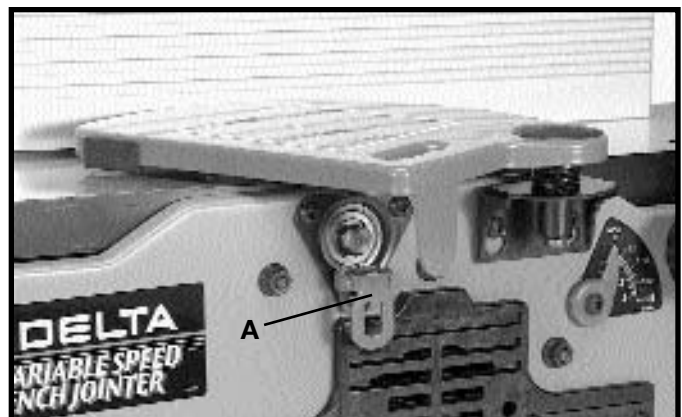

Fig. 16

FASTENING JOINTER TO SUPPORTING SURFACE

If during operation, there is any tendency for the jointer to tip over, slide or walk on the supporting surface, the jointer must be secured to the supporting surface with fasteners through the four holes, two of which are shown at (A) Fig. 20, in the jointer base.



Fig. 20

OPERATING CONTROLS AND ADJUSTMENTS

STARTING AND STOPPING JOINTER

The on/off switch (A) Fig. 21, is located on the front of the jointer cabinet. To turn the machine “ON,” move the switch (A) to the up position. To turn the machine “OFF,” move the switch (A) to the down position.

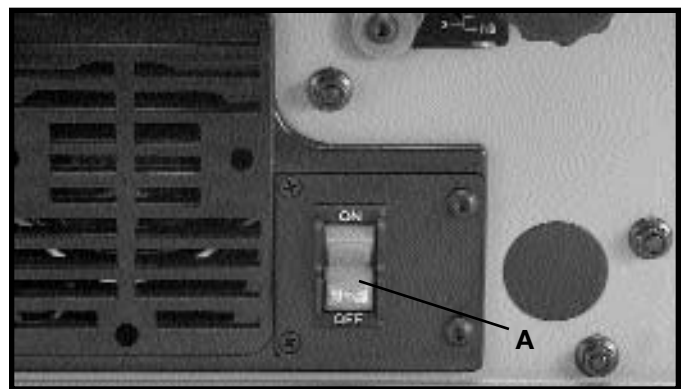

Fig. 21

LOCKING SWITCH IN THE “OFF” POSITION

IMPORTANT: When the tool is not in use, the switch should be locked in the “OFF” position to prevent unauthorized use. Grasp the switch toggle (B) and pull it out as shown in Fig. 22. With the switch toggle (B) removed, the switch will not operate. However, should the switch toggle be removed while the machine is running, it can be turned “OFF” once, but cannot be restarted without inserting the switch toggle (B).



Fig. 22

VARIABLE SPEED CONTROL

Your jointer is supplied with a variable speed control knob (A) Fig. 23, that enables you to operate the machine at cutterhead speeds between 6000 and 11,000 RPM. Speed indicators of 1-2-3-4 and 5 are provided on the speed dial as shown. When the pointer (B) is pointing to 1, the cutterhead speed will be 6000 RPM; 2 – 7250 RPM; 3 – 8800 RPM; 4 – 9750 RPM; and 5 – 11,000 RPM.

SPEED CONTROL CHART

A speed control chart (C) Fig. 23, indicates the recommended cutterhead speed setting when jointing plastics, soft woods and hard woods from 1-1/2" to 6" wide.

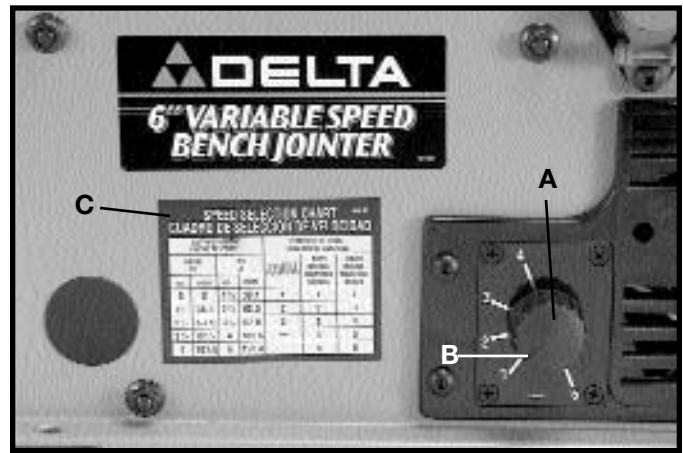

Fig. 23

DEPTH OF CUT ADJUSTMENT

The jointer can be set to cut any depth from a very thin shaving to 1/8" deep. A dual English/Metric scale (A) Fig. 24, and pointer (B) are provided to indicate the depth of cut. To adjust for depth of cut, loosen lock knob (C) and turn adjusting knob (D) clockwise to lower and counterclockwise to raise the infeed table. After the infeed table is at the desired setting, tighten lock knob (C). **NOTE:** For best results, final positioning of the infeed table should always be made from the bottom to the up position.

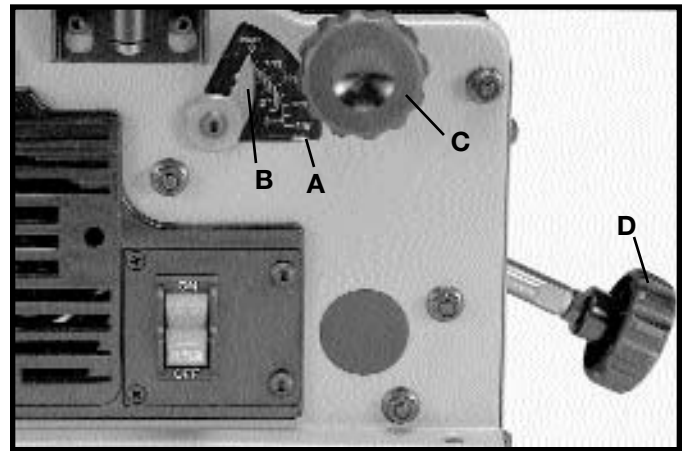

Fig. 24

FENCE ADJUSTMENTS

The fence can be moved across the table and can be tilted up to 45 degrees to the right, as follows:

1. To move the fence across the table, loosen lock lever (A) Fig. 25, slide the fence to the desired position on the table and tighten lever (A). **NOTE:** Lock lever (A) is spring loaded and can be repositioned by pulling up on the lever and repositioning it on the nut located underneath the lever.

2. To tilt the fence, loosen lever (B) Fig. 25, and tilt the fence to the desired angle. Then tighten lever (B). **NOTE:** Lever (B) is spring loaded and can be repositioned by pulling out on the lever and repositioning it on the nut located underneath the lever.

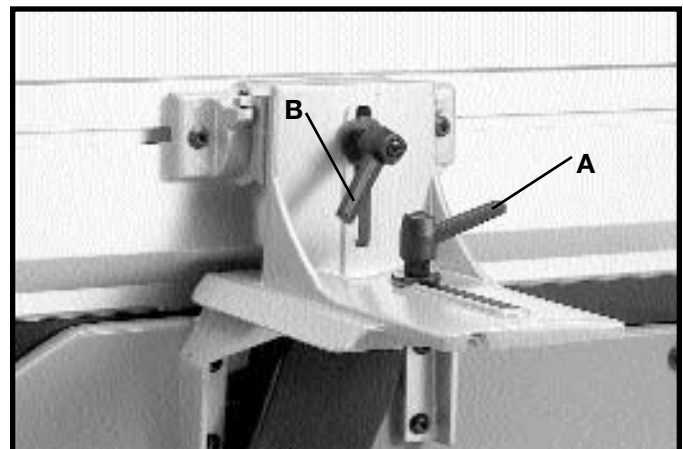

Fig. 25

3. The fence features adjustable positive stops at the most used fence positions of 90 degrees and 45 degrees to the right. To check and adjust the positive stops, proceed as follows:

4. Place a square (C) Fig. 26, on the table with one end of the square against the fence as shown. Adjust the fence until it is exactly 90 degrees to the table.

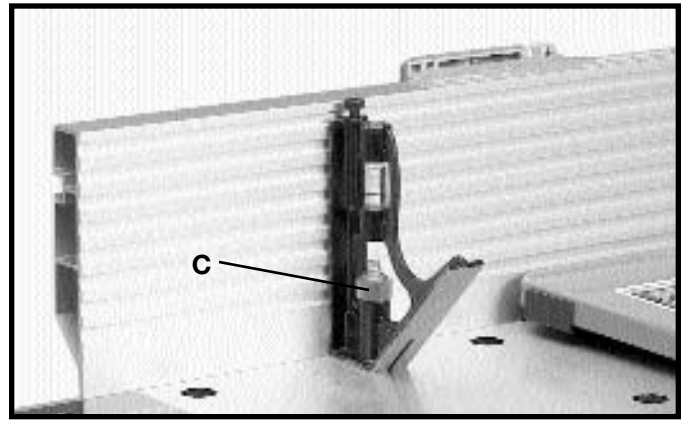

Fig. 26

5. Turn set screw (D) Fig. 27, until it contacts stop (E).

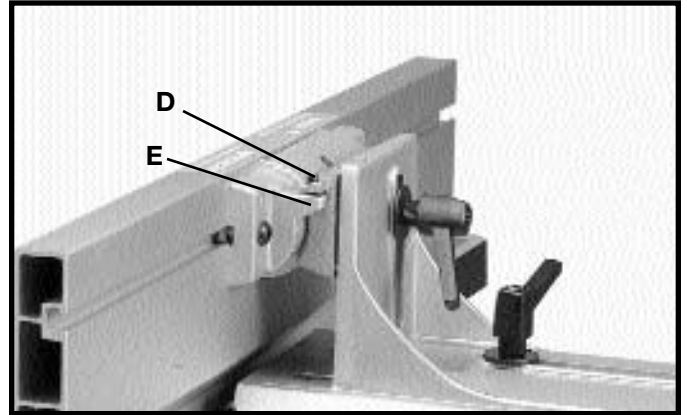

Fig. 27

6. Using a square (C) Fig. 28, tilt the table to the 45 degree position and make sure the fence is 45 degrees to the table. Adjust the fence if necessary.

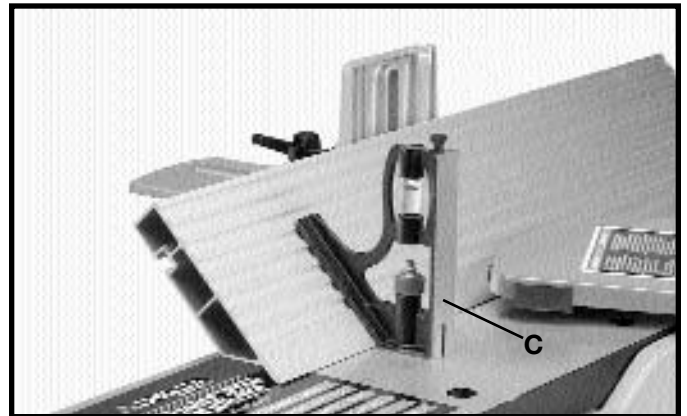

Fig. 28

7. Turn set screw (F) Fig. 29, until it contacts stop (G).

8. These positive stops enable you to rapidly position the table to the 90 and 45 degree settings.

CAUTION: MAKE SURE THE FENCE IS IN LEVEL CONTACT WITH THE SURFACE OF THE OUTFEED TABLE.

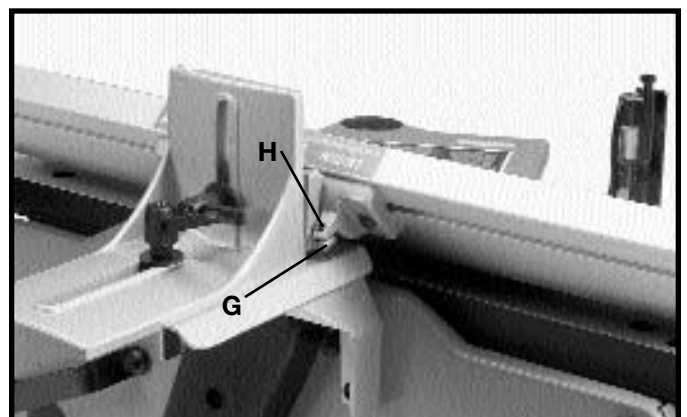

Fig. 29

ADJUSTING KNIVES

When it becomes necessary to adjust the knives due to replacement or wear, proceed as follows:

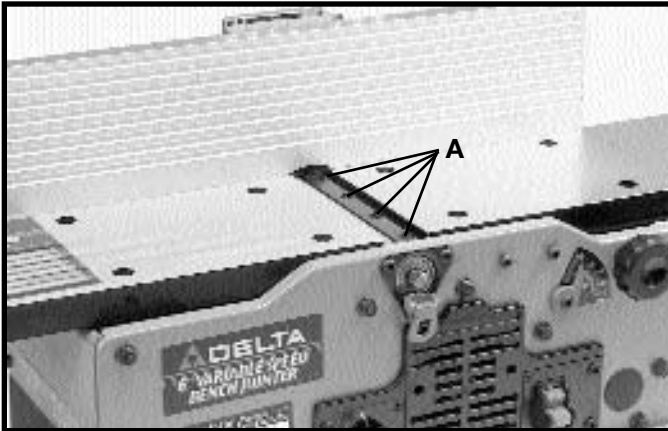

Fig. 30

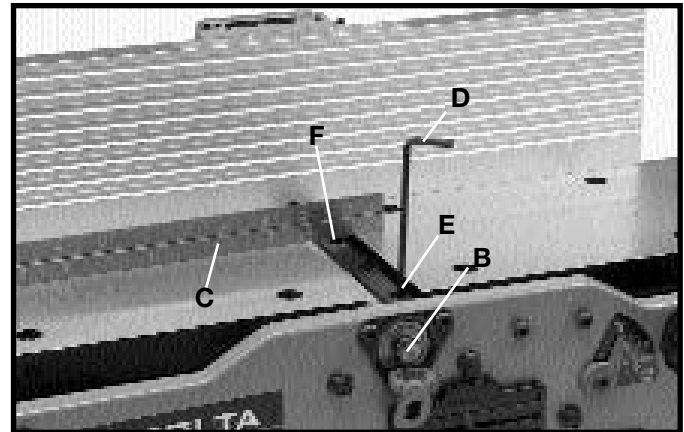

Fig. 31

1. DISCONNECT THE TOOL FROM THE POWER SOURCE AND REMOVE CUTTERHEAD GUARD.

2. Rotate cutterhead and loosen four screws (A) Fig. 30. **NOTE:** Do not overly loosen the screws (A). Loosen one half turn or only enough so knife can slide between locking plate and cutterhead.

3. Rotate cutterhead and engage cutterhead lock (B) Fig. 31, on cutterhead shaft as shown. This will position knives for proper adjustment to the outfeed table.

4. Place a straight edge (C) Fig. 31, on the outfeed table extending out over the knife as shown. Using wrench (D) supplied, turn screw (E) until knife just touches straight edge. Adjust knife at far end of cutterhead in the same manner turning screw (F). Tighten four screws (A) Fig. 30, after adjustment is made.

5. Adjust remaining knife in the same manner and **MAKE SURE CUTTERHEAD LOCK (B) IS DISENGAGED AFTER ADJUSTMENT IS COMPLETED AND REPLACE CUTTERHEAD GUARD.**

6. The following are examples of what will happen if the knives are not adjusted properly.

7. If the knives are set too low, the result will be as shown in Fig. 32, and the finished surface will be curved.

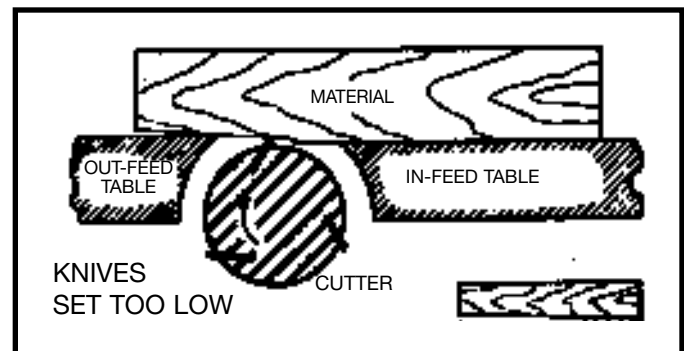

Fig. 32

8. If the knives are set too high, the work will be gouged at the end of the cut, as shown in Fig. 33.

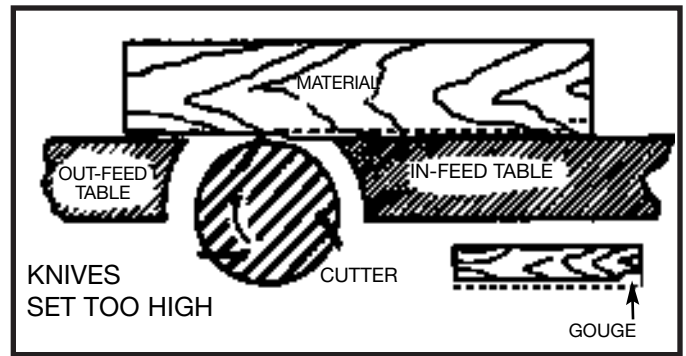

Fig. 33

9. As a final check, run a piece of work slowly over the knives for 6 to 8 inches. The wood should rest firmly on both tables as shown in Fig. 34, with no open spaces under the finished cut.

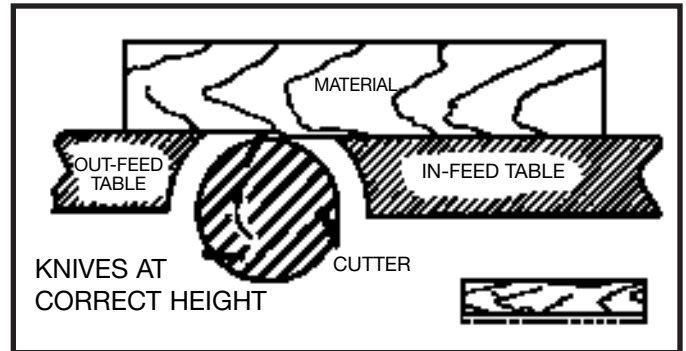

Fig. 34

CHIP AND DUST CHUTE

A chip and dust chute (A) Fig. 35, is provided on the outfeed end of the jointer base for efficient chip removal. **CAUTION: KEEP HANDS OUT OF CHIP AND DUST CHUTE AT ALL TIMES.**



Fig. 35

CORD STORAGE

A cord storage bracket (A) Fig. 36, is provided on jointer base for storage of the cord when machine is not in use.

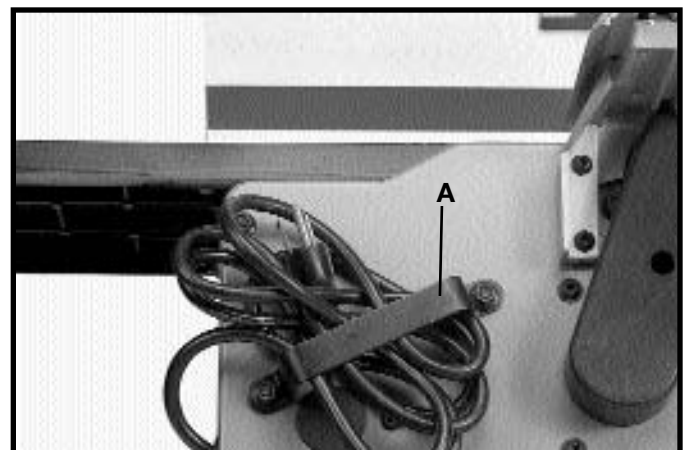

Fig. 36

PUSH BLOCKS

A set of push blocks (A) Fig. 37, is supplied with your jointer and should be used whenever possible to minimize all danger to your hands. Fig. 37, illustrates using the push blocks properly.

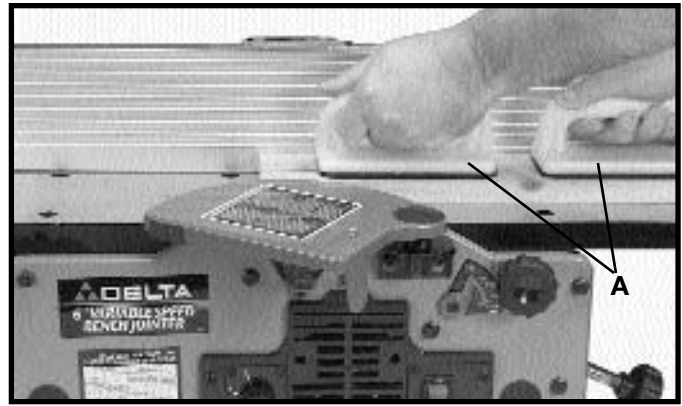

Fig. 37

OPERATION

The following directions will give the beginner a start on jointer operations. Use scrap pieces of lumber to check the settings and to get the feel of the operations before attempting regular work.

⚠ WARNING: ALWAYS USE CUTTERHEAD GUARD AND KEEP HANDS AWAY FROM CUTTERHEAD. USE PUSH BLOCKS WHENEVER POSSIBLE.

PLACEMENT OF HANDS DURING FEEDING

At the start of the cut, the left hand holds the work firmly against the infeed table and fence, while the right hand pushes the work toward the knives. After the cut is underway, the new surface rests firmly on the outfeed table as shown in Fig. 38. The left hand should then be moved to the work on the outfeed table, at the same time maintaining flat contact with the fence. The right hand presses the work forward, and before the right hand reaches the cutterhead it should be moved to the work on the outfeed table. **CAUTION: NEVER PASS HANDS DIRECTLY OVER THE CUTTERHEAD.**

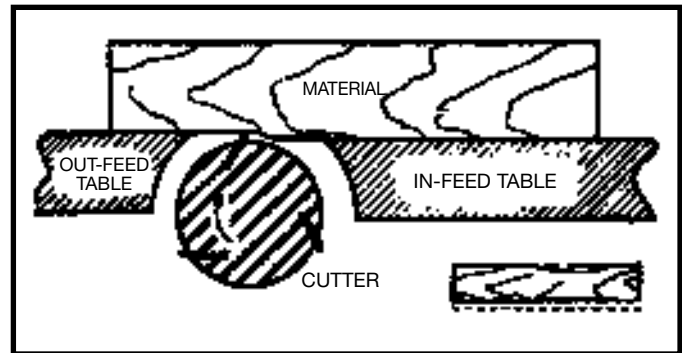

Fig. 38

JOINTING AN EDGE

This is the most common operation for the jointer. Set the guide fence square with the table. Depth of cut should be the minimum required to obtain a straight edge. Hold the best face of the piece firmly against the fence throughout the feed as shown in Fig. 39.

DO NOT PERFORM JOINTING OPERATIONS ON MATERIAL SHORTER THAN 10 INCHES, NARROWER THAN 3/4 INCH, OR LESS THAN 1/2 INCH THICK (REFER TO FIG. 39A).



Fig. 39

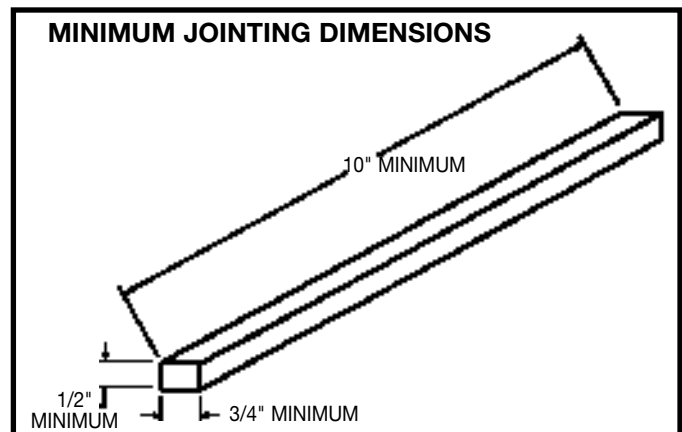

Fig. 39A

PLANING WARPED PIECES

If the wood to be planed is dished or warped, take light cuts until the surface is flat. Avoid forcing such material down against the table; excessive pressure will spring it while passing the knives, and it will spring back and remain curved after the cut is completed.

PLANING SHORT OR THIN WORK

When planing short or thin pieces, always use push blocks to minimize all danger to the hands. Fig. 40, illustrates using the Push Blocks properly.

DO NOT PERFORM PLANING OPERATIONS ON MATERIAL SHORTER THAN 10 INCHES, NARROWER THAN 3/4 INCH, WIDER THAN 6 INCHES, OR LESS THAN 1/2 INCH THICK (REFER TO FIG. 40A).

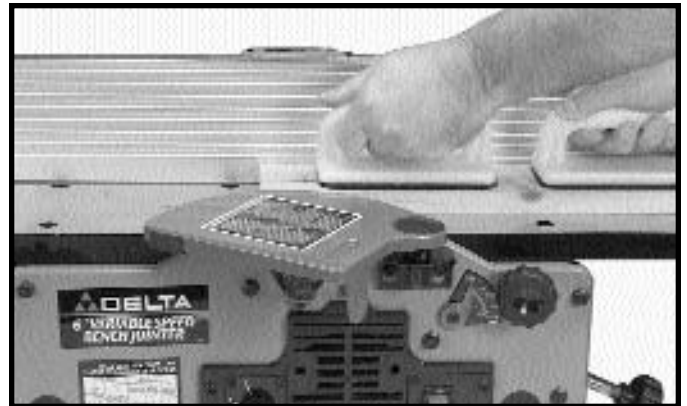

Fig. 40

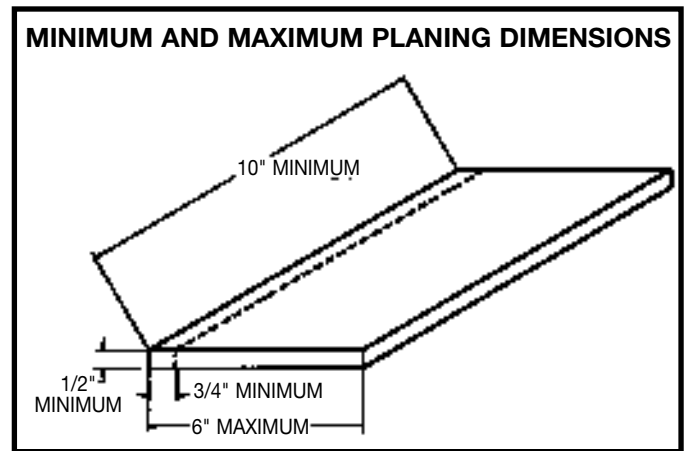

Fig. 40A

DIRECTION OF GRAIN

Avoid feeding work into the jointer against the grain as shown in Fig. 41. The result will be chipped and splintered edges. Feed with the grain as shown in Fig. 42, to obtain a smooth surface.

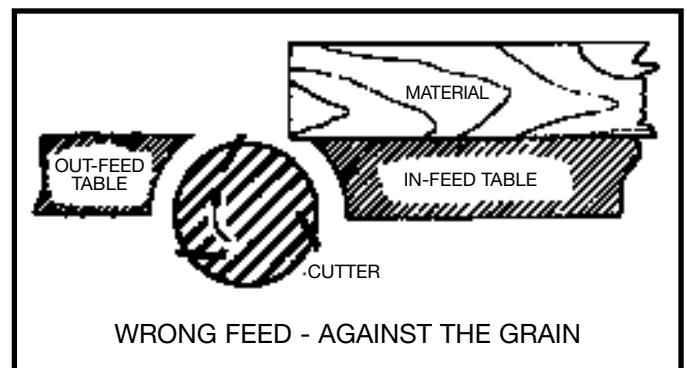

Fig. 41

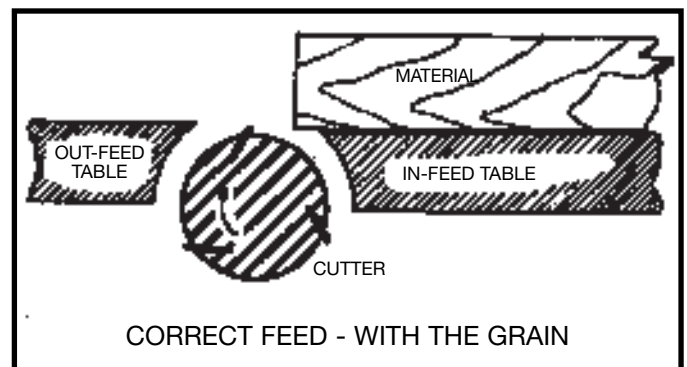

Fig. 42

MAINTENANCE

BELT REPLACEMENT

When it becomes necessary to replace the belt on your jointer, proceed as follows:

1. **DISCONNECT THE TOOL FROM THE POWER SOURCE.**
2. Remove screw (A) Fig. 43, using Allen wrench supplied, and remove belt guard (B).
3. Loosen three screws (C) Fig. 44, to release belt tension and remove belt (D) from pulleys.
4. Assemble new belt to the cutterhead and motor pulleys. Press down on motor pulley (E) Fig. 44, to tension belt and tighten three screws (C).
5. Replace belt guard (B) Fig. 44.

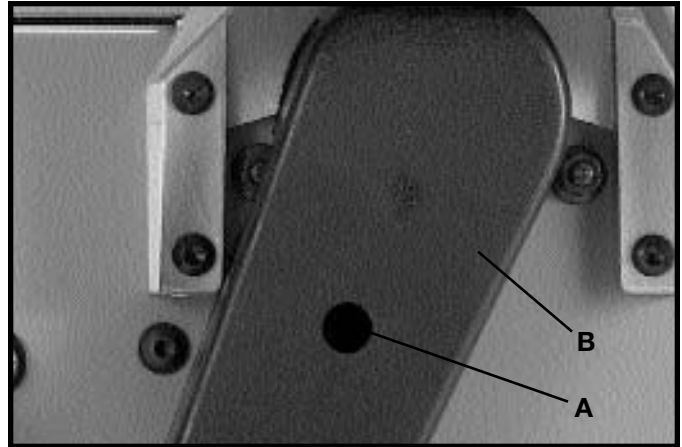

Fig. 43

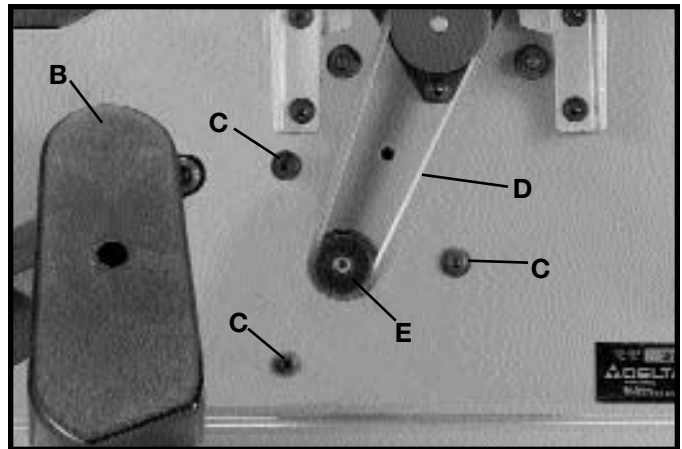



Fig. 44

ACCESSORIES

A complete line of accessories is available from your Delta Supplier, Porter-Cable • Delta Factory Service Centers, and Delta Authorized Service Stations. Please visit our Web Site www.deltamachinery.com for a catalog or for the name of your nearest supplier.

 **WARNING:** Since accessories, other than those offered by Delta, have not been tested with this product, use of such accessories could be hazardous. For safest operation, only Delta recommended accessories should be used with this product.

37-108 Push Blocks



PARTS, SERVICE OR WARRANTY ASSISTANCE

All Delta Machines and accessories are manufactured to high quality standards and are serviced by a network of Porter-Cable • Delta Factory Service Centers and Delta Authorized Service Stations. To obtain additional information regarding your Delta quality product or to obtain parts, service, warranty assistance, or the location of the nearest service outlet, please call 1-800-223-7278 (In Canada call 1-800-463-3582).



Delta Building Trades and Home Shop Machinery Two Year Limited Warranty

Delta will repair or replace, at its expense and at its option, any Delta machine, machine part, or machine accessory which in normal use has proven to be defective in workmanship or material, provided that the customer returns the product prepaid to a Delta factory service center or authorized service station with proof of purchase of the product within two years and provides Delta with reasonable opportunity to verify the alleged defect by inspection. Delta may require that electric motors be returned prepaid to a motor manufacturer's authorized station for inspection and repair or replacement. Delta will not be responsible for any asserted defect which has resulted from normal wear, misuse, abuse or repair or alteration made or specifically authorized by anyone other than an authorized Delta Service facility or representative. Under no circumstances will Delta be liable for incidental or consequential damages resulting from defective products. This warranty is Delta's sole warranty and sets forth the customer's exclusive remedy, with respect to defective products; all other warranties, express or implied, whether of merchantability, fitness for purpose, or otherwise, are expressly disclaimed by Delta.

NOTES

PORTER-CABLE DELTA SERVICE CENTERS (CENTROS DE SERVICIO DE PORTER-CABLE DELTA)

Parts and Repair Service for Porter-Cable/Delta Power Tools are Available at These Locations
(Obtenga Refaccion de Partes o Servicio para su Herramienta en los Siguientes Centros de Porter-Cable Delta)

ARIZONA

Tempe 85282 (Phoenix)
2400 West Southern Avenue
Suite 105
Phone: (602) 437-1200
Fax: (602) 437-2200

CALIFORNIA

Ontario 91761 (Los Angeles)
3949A East Guasti Road
Phone: (909) 390-5555
Fax: (909) 390-5554

San Leandro 94577 (Oakland)
3039 Teagarden Street
Phone: (510) 357-9762
Fax: (510) 357-7939

FLORIDA

Davie 33314 (Miami)
4343 South State Rd. 7 (441)
Unit #107
Phone: (954) 321-6635
Fax: (954) 321-6638

Tampa 33609
4538 W. Kennedy Boulevard
Phone: (813) 877-9585
Fax: (813) 289-7948

GEORGIA

Forest Park 30297 (Atlanta)
5442 Frontage Road,
Suite 112
Phone: (404) 608-0006
Fax: (404) 608-1123

ILLINOIS

Addison 60101 (Chicago)
311 Laura Drive
Phone: (630) 628-6100
Fax: (630) 628-0023

Woodridge 60517 (Chicago)
2033 West 75th Street
Phone: (630) 910-9200
Fax: (630) 910-0360

MARYLAND

Elkridge 21075 (Baltimore)
7397-102 Washington Blvd.
Phone: (410) 799-9394
Fax: (410) 799-9398

MASSACHUSETTS

Braintree 02185 (Boston)
719 Granite Street
Phone: (781) 848-9810
Fax: (781) 848-6759

Franklin 02038 (Boston)
Franklin Industrial Park
101E Constitution Blvd.
Phone: (508) 520-8802
Fax: (508) 528-8089

MICHIGAN

Madison Heights 48071 (Detroit)
30475 Stephenson Highway
Phone: (248) 597-5000
Fax: (248) 597-5004

MINNESOTA

Minneapolis 55429
4315 68th Avenue North
Phone: (763) 561-9080
Fax: (763) 561-0653

MISSOURI

North Kansas City 64116
1141 Swift Avenue
P.O. Box 12393
Phone: (816) 221-2070
Fax: (816) 221-2897

St. Louis 63119
7574 Watson Road
Phone: (314) 968-8950
Fax: (314) 968-2790

NEW YORK

Flushing 11365-1595 (N.Y.C.)
175-25 Horace Harding Expwy.
Phone: (718) 225-2040
Fax: (718) 423-9619

NORTH CAROLINA

Charlotte 28270
9129 Monroe Road, Suite 115
Phone: (704) 841-1176
Fax: (704) 708-4625

OHIO

Columbus 43214
4560 Indianola Avenue
Phone: (614) 263-0929
Fax: (614) 263-1238

Cleveland 44125
8001 Sweet Valley Drive
Unit #19
Phone: (216) 447-9030
Fax: (216) 447-3097

OREGON

Portland 97230
4916 NE 122 nd Ave.
Phone: (503) 252-0107
Fax: (503) 252-2123

PENNSYLVANIA

Willow Grove 19090
520 North York Road
Phone: (215) 658-1430
Fax: (215) 658-1433

TEXAS

Carrollton 75006 (Dallas)
1300 Interstate 35 N, Suite 112
Phone: (972) 446-2996
Fax: (972) 446-8157

Houston 77055
West 10 Business Center
1008 Wirt Road, Suite 120
Phone: (713) 682-0334
Fax: (713) 682-4867

WASHINGTON

Renton 98055 (Seattle)
268 Southwest 43rd Street
Phone: (425) 251-6680
Fax: (425) 251-9337

Authorized Service Stations are located in many large cities. Telephone **800-487-8665** or **731-541-6042** for assistance locating one. Parts and accessories for Porter-Cable Delta products should be obtained by contacting any Porter-Cable Delta Distributor, Authorized Service Center, or Porter-Cable Delta Factory Service Center. If you do not have access to any of these, call **888-848-5175** and you will be directed to the nearest Porter-Cable Delta Factory Service Center. Las Estaciones de Servicio Autorizadas están ubicadas en muchas grandes ciudades. Llame al **800-487-8665** ó al **731-541-6042** para obtener asistencia a fin de localizar una. Las piezas y los accesorios para los productos Porter-Cable Delta deben obtenerse poniéndose en contacto con cualquier distribuidor Porter-Cable Delta, Centro de Servicio Autorizado o Centro de Servicio de Fábrica Porter-Cable Delta. Si no tiene acceso a ninguna de estas opciones, llame al **888-848-5175** y le dirigirán al Centro de Servicio de Fábrica Porter-Cable Delta más cercano.

ALBERTA

Bay 6, 2520-23rd St. N.E.
Calgary, Alberta
T2E 8L2
Phone: (403) 735-6166
Fax: (403) 735-6144

BRITISH COLUMBIA

8520 Baxter Place
Burnaby, B.C.
V5A 4T8
Phone: (604) 420-0102
Fax: (604) 420-3522

MANITOBA

1699 Dublin Avenue
Winnipeg, Manitoba
R3H 0H2
Phone: (204) 633-9259
Fax: (204) 632-1976

ONTARIO

505 Southgate Drive
Guelph, Ontario
N1H 6M7
Phone: (519) 836-2840
Fax: (519) 767-4131

QUÉBEC

1515 ave.
St-Jean Baptiste,
Québec, Québec
G2E 5E2
Phone: (418) 877-7112
Fax: (418) 877-7123

1447, Begin
St-Laurent, (Montréal), Québec
H4R 1V8
Phone: (514) 336-8772
Fax: (514) 336-3505

The following are trademarks of PORTER-CABLE DELTA Corporation (Las siguientes son marcas registradas de PORTER-CABLE S.A.): BAMMER®, INNOVATION THAT WORKS®, JETSTREAM®, LASERLOC®, OMNIJIG®, POCKET CUTTER®, PORTA-BAND®, PORTA-PLANE®, PORTER-CABLE®, QUICKSAND®, SANDTRAP®, SAW BOSS®, SPEED-BLOC®, SPEEDMATIC®, SPEEDTRONIC®, STAIR-EASE®, THE PROFESSIONAL EDGE®, THE PROFESSIONAL SELECT®, TIGER CUB®, TIGER SAW®, TORQBUSTER®, WHISPER SERIES®, DURATRONIC™, FLEX™, FRAME SAW™, MICRO-SET™, MORTEN™, NETWORK™, RIPTIDE™, TRU-MATCH™, WOODWORKER'S CHOICE™.

Trademarks noted with ® are registered in the United States Patent and Trademark Office and may also be registered in other countries. Las Marcas Registradas con el signo de ® son registradas por la Oficina de Registros y Patentes de los Estados Unidos y también pueden estar registradas en otros países.