

IMPORTANT MANUAL Do Not Throw Away

WEED EATER

TRADEMARK ©

OPERATOR'S MANUAL:

▲ DANGER: Read the Operator's Manual and Follow All Warnings and Safety Instructions. Failure To Do So Can Result in Serious Injury.

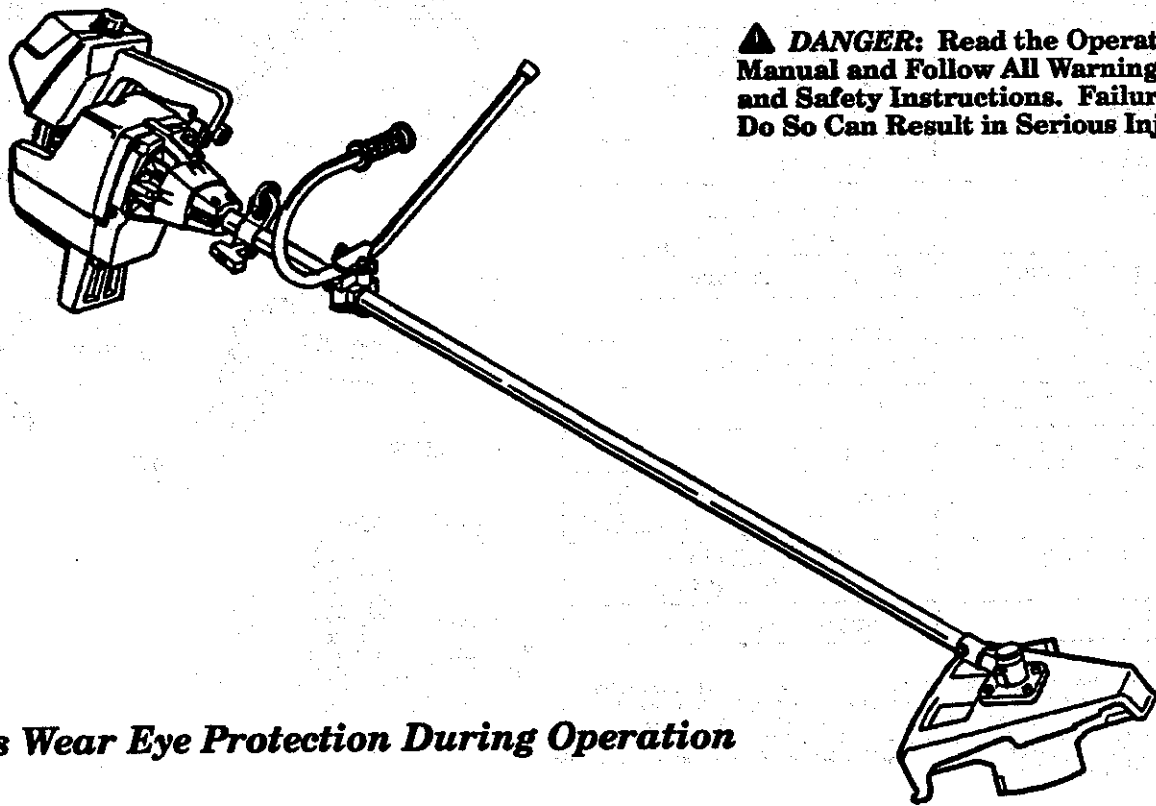

Always Wear Eye Protection During Operation

MODEL:

GTI™ 19

**GAS POWERED
LINE TRIMMER W/BLADE**

TABLE OF CONTENTS

<p>WARNINGS AND SAFETY INSTRUCTIONS .. 3</p> <p>KNOW YOUR UNIT 5</p> <p>ASSEMBLY 6</p> <p>ENGINE INFORMATION 11</p> <p style="padding-left: 20px;">A. Fueling Your Engine 11</p> <p style="padding-left: 20px;">B. Pre-Operation Checks 11</p> <p style="padding-left: 20px;">C. Starting Instructions 12</p> <p style="padding-left: 20px;">D. Operating Instructions 13</p> <p>USING YOUR TOOL AS A BRUSHCUTTER .. 14</p> <p style="padding-left: 20px;">A. Blade Safety 15</p> <p style="padding-left: 20px;">B. Guard Against Blade Thrust 15</p> <p style="padding-left: 20px;">C. Cutting Methods 16</p>	<p>USING YOUR TOOL AS A LINE TRIMMER</p> <p style="padding-left: 20px;">A. Trimmer Safety 17</p> <p style="padding-left: 20px;">B. Line Advance 17</p> <p style="padding-left: 20px;">C. Cutting Methods 17</p> <p style="padding-left: 20px;">D. Line Replacement 18</p> <p>ACCESSORIES 20</p> <p>GENERAL MAINTENANCE</p> <p style="padding-left: 20px;">A. Maintenance Safety 21</p> <p style="padding-left: 20px;">B. Starter Rope 21</p> <p style="padding-left: 20px;">C. Carburetor Adjustments 22</p> <p style="padding-left: 20px;">D. Air Filter 24</p> <p style="padding-left: 20px;">E. Flexible Drive Shaft Lubrication 24</p> <p style="padding-left: 20px;">F. Blade Sharpening 25</p> <p style="padding-left: 20px;">G. Trouble Shooting Chart 26</p>
---------------------------------------------------------------------------------------------------------------------------------------------------------------------------------------------------------------------------------------------------------------------------------------------------------------------------------------------------------------------------------------------------------------------------------------------------------------------------------------------------------------------------------------------------------------------------------------------------------------------------------------------------------------------------------------------------------------	-------------------------------------------------------------------------------------------------------------------------------------------------------------------------------------------------------------------------------------------------------------------------------------------------------------------------------------------------------------------------------------------------------------------------------------------------------------------------------------------------------------------------------------------------------------------------------------------------------------------------------------------------------------------------------------------------------------------------------------------------------------------------------------------------------------------------------------------------------------------

SPECIFICATIONS

ENGINE TYPE:	2-Cycle, Air Cooled
DISPLACEMENT:	30cc
ENGINE RPM:	Operating—7500 Idle—2600-3400
IGNITION:	Solid State
CARBURETOR:	Diaphragm All Position With Adjustable Fuel Mixture Jets
ENGINE "OFF":	Positive Switch
STARTER:	Auto Rewind
MUFFLER:	Temperature Limiting (not spark arresting)
CUTTING PATH:	18" (as line trimmer)
FUEL TANK:	400cc
SPARK PLUG:	Champion (CJ-14)
SPARK PLUG GAP:	.025"
MODULE AIR GAP:	.010" to .014"
LUBRICATION:	Gasoline/Oil Mixture - 40:1 (see "Fueling Your Engine")
CUTTING LINE:	.080" Dia. WEED LINE® Brand Line
BLADE	4 point 8" Weed Blade

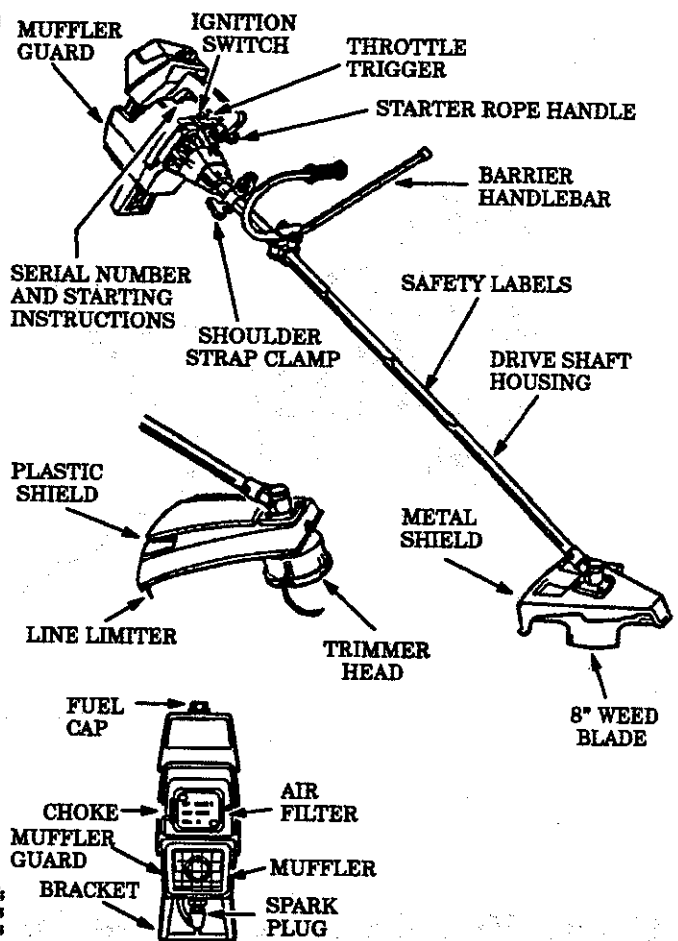

MANUFACTURED UNDER ONE OR MORE OF THE FOLLOWING U.S. PATENTS: 3,708,987; 3,826,088; 3,858,778; 4,035,912; 4,052,789; 4,054,993; 4,067,108; 4,104,797; 4,107,901; 4,112,853; 4,114,369; 4,124,938; 4,136,446; 4,156,313; 4,156,967; 4,161,828; 4,167,812; 4,169,572; 4, 183,128; 4,188,933; 4,311,004; 4,311,005; 4,236,312; 4,269,272; 4,269,675; 4,290,200; 4,362,974; 4,366,632; 4,382,256; 4,451,983; & 4,483,068. OTHER U.S. AND FOREIGN PATENTS PENDING.

SPECIAL NOTICE

For users on U.S. Forest Land and in some states, including California (Public Resources Codes 4442 and 4443), Idaho, Maine, Minnesota, New Jersey, Oregon, and Washington: Certain internal combustion engines operated on forest, brush, and/or grass-covered land in the above areas are required to be equipped with a spark arrester, maintained in effective working order, or the engine must be constructed, equipped, and maintained for the prevention of fire. Check with your state or local authorities for regulations pertaining to these requirements. Failure to follow these requirements is a violation of the law. **This unit is not factory-equipped with a spark arrester;** however, a spark arrester is available as an optional part. If a spark arrester is required in your area, contact your Authorized Service Dealer for the correct kit.

▲ WARNINGS AND SAFETY INSTRUCTIONS

(See Additional Safety Instructions throughout this Manual)

▲ DANGER – THIS POWER TOOL CAN BE DANGEROUS! This tool can cause serious injury including amputation or blindness to the operator and others. The warnings and safety instructions in this manual must be followed to provide reasonable safety and efficiency in using this tool. The operator is responsible for following the warnings and instructions in this manual and on the tool. Read the entire Operator's Manual before assembling and using this tool! Restrict the use of this power tool to persons who read, understand and follow the warnings and instructions in this manual and on the tool.

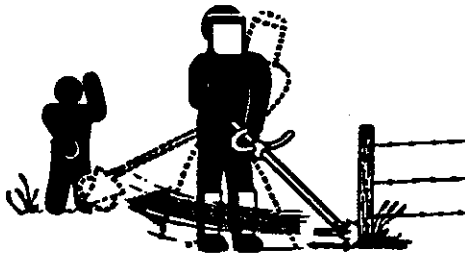

▲ DANGER

BLADE CAN THRUST VIOLENTLY AWAY FROM MATERIAL IT DOES NOT CUT.

- BLADE THRUST CAN CAUSE AMPUTATION OF ARMS OR LEGS.
- KEEP PEOPLE AND ANIMALS 30 FEET (10 METERS) AWAY.

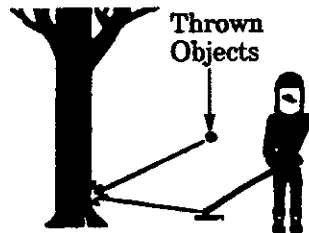

▲ WARNING

BLADE/TRIMMER LINE CAN THROW OBJECTS VIOLENTLY.

- YOU CAN BE BLINDED OR INJURED.
- WEAR EYE AND LEG PROTECTION.

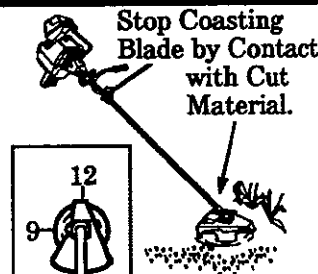
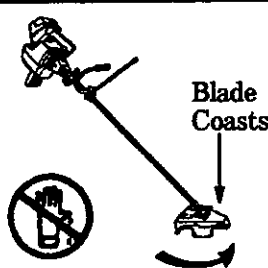

▲ WARNING

BLADE/TRIMMER LINE CAN THROW OBJECTS VIOLENTLY.

- THE BLADE CAN SERIOUSLY CUT YOU OR OTHERS.
- STOP THE BLADE WITH CUT MATERIAL.

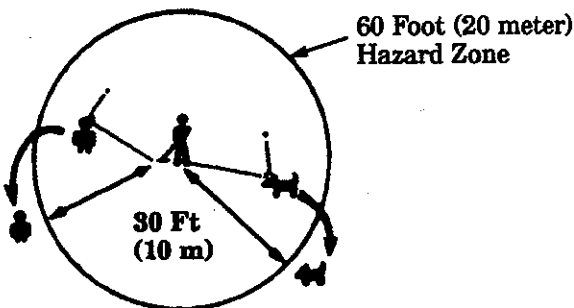

▲ WARNING

HAZARD ZONE FOR THROWN OBJECTS

- BLADE/TRIMMER LINE CAN THROW OBJECTS VIOLENTLY.
- OTHERS CAN BE BLINDED OR INJURED.
- KEEP PEOPLE AND ANIMALS 30 FEET (10 METERS) AWAY.



▲ WARNING

READ OPERATOR'S MANUAL.

- FOLLOW ALL WARNINGS AND INSTRUCTIONS.
- FAILURE TO DO SO CAN RESULT IN SERIOUS INJURY.

NOTES

The first part of the document discusses the importance of maintaining accurate records of all transactions. It emphasizes that proper record-keeping is essential for the success of any business and for the protection of the interests of all parties involved. The text also mentions the need for regular audits and the importance of having a clear system in place for recording and organizing financial data.

In addition, the document highlights the role of technology in modern accounting. It notes that the use of accounting software can significantly improve efficiency and accuracy in financial reporting. However, it also cautions that users must be trained properly and that data security is a top priority when implementing such systems.

The second part of the document focuses on the ethical responsibilities of accountants. It stresses that accountants have a duty to act with integrity and to provide unbiased and truthful information. The text discusses various ethical dilemmas that accountants may face and provides guidance on how to handle them in a professional and ethical manner.

Furthermore, the document touches upon the importance of communication in the accounting profession. It explains that accountants must be able to communicate complex financial information in a clear and concise manner to their clients and other stakeholders. Effective communication is key to building trust and ensuring that all parties understand the financial situation and the recommendations being made.

The document also addresses the issue of confidentiality. It states that accountants are often entrusted with sensitive financial information, and it is their responsibility to protect this information from unauthorized access and disclosure. This includes implementing strong security measures and adhering to strict confidentiality protocols.

Finally, the document concludes by reiterating the importance of continuous learning and professional development in the accounting field. It encourages accountants to stay up-to-date on the latest industry trends, regulations, and technologies to ensure they are providing the highest quality of service to their clients.

In summary, the document provides a comprehensive overview of the key aspects of the accounting profession, from record-keeping and technology to ethics and communication. It serves as a valuable resource for anyone interested in the field and offers practical advice on how to navigate the challenges and responsibilities of an accountant.

WARNINGS AND SAFETY INSTRUCTIONS....(Continued)

▲ OPERATOR SAFETY

1. Always wear a safety face shield or safety goggles. See "Accessories."
2. Always wear heavy, long pants, boots and gloves. Wearing safety leg guards is recommended. See "Accessories." Do not wear loose clothing, jewelry, short pants, sandals or go barefoot. Secure hair so it is above shoulder length. Being fully covered will help protect you from pieces of toxic plants such as poison ivy thrown by the tool which could be more of a hazard than touching the plant itself.
3. Do not operate this tool when you are tired, ill or under the influence of alcohol, drugs or medication.
4. Wear hearing protection if you use this tool for more than 1 1/2 hours per day.
5. Never start or run the engine inside a closed room or building. Breathing exhaust fumes can kill.
6. Keep handles free of oil and fuel.
7. Always use the handlebar and a properly adjusted shoulder strap with a blade. See "Assembly."

▲ TOOL SAFETY

8. Inspect entire tool before each use. Replace damaged parts. Check for fuel leaks. Make sure all fasteners are in place and securely fastened.
9. Throw away blades that are bent, warped, cracked, broken, or damaged in any other way. Replace trimmer head parts that are cracked, chipped, or damaged before using the tool.
10. Use only Weed Eater .080" diameter Weed Line. Never use wire, rope, string etc.
11. Install the required shield properly before using the tool. Use the metal shield for all weed blade use. Use the plastic shield for all line trimmer use.
12. Use only the specified blade or trimmer head. Make sure the trimmer head is properly installed and securely fastened. Refer to "Assembly."
13. Be sure blade or trimmer head stops turning when engine idles. See "Carburetor Adjustments."
14. Make carburetor adjustments with the drive shaft housing supported to prevent the blade or trimmer line from contacting any object. Hold the tool by hand; do not use the shoulder strap for support.
15. Keep others away when making carburetor adjustments.
16. Use only genuine Weed Eater accessories as recommended for this tool.

▲ FUEL SAFETY

17. Mix and pour fuel outdoors and where there are no sparks or flames.
18. Use a container approved for fuel.
19. Do not smoke or allow smoking near fuel or the tool or while using the tool.
20. Wipe up all fuel spills before starting engine.
21. Move at least 10 feet (3 meters) away from fueling site before starting engine.
22. Stop engine before removing fuel cap.
23. Empty the fuel tank before storing the tool. Use up fuel left in the carburetor by starting the engine and letting the engine run until it stops.

24. Store tool and fuel in an area where fuel vapors cannot reach sparks or open flames from water heaters, electric motors or switches, furnaces, etc.

▲ CUTTING SAFETY

25. Inspect the area to be cut before each use. Remove objects (rocks, broken glass, nails, wire, string, etc.) which can be thrown or become entangled in the blade or trimmer head.
26. Keep others including children, animals, bystanders and helpers outside the 60 foot (20 meter) Hazard Zone. Stop the engine immediately if you are approached.
27. Always keep engine on the right-hand side of your body.
28. Hold the tool firmly with both hands.
29. Keep firm footing and balance. Do not over-reach.
30. Keep blade or trimmer head below waist level.
31. Do not raise the engine above your waist. The blade or trimmer head can come dangerously close to your body.
32. Keep all parts of your body away from the blade, trimmer head, and muffler.
33. Cut from your right to your left.
34. Use only for jobs explained in this manual.

▲ MAINTENANCE SAFETY

35. Maintain the tool according to recommended procedures. Keep the blade sharp and the cutting line at the proper length.
36. Never start engine with the clutch shroud removed. The clutch can fly off and cause serious injury.
37. Disconnect the spark plug before performing maintenance (except for carburetor adjustments).
38. Make carburetor adjustments with the drive shaft housing supported to prevent the blade or trimmer line from contacting any object. Hold the tool by hand; do not use the shoulder strap for support.
39. Keep others away when making carburetor adjustments.
40. Use only genuine Weed Eater replacement parts as recommended.

▲ TRANSPORTING AND STORAGE

41. Hand carry the tool with the engine stopped and the muffler away from your body.
42. Allow the engine to cool, empty the fuel tank and secure the tool before storing or transporting in a vehicle.
43. Empty the fuel tank before storing the tool. Use up fuel left in the carburetor by starting the engine and letting the engine run until it stops.
44. Store tool and fuel in an area where fuel vapors cannot reach sparks or open flames from water heaters, electric motors or switches, furnaces, etc.
45. Store tool so the blade or line limiter cannot accidentally cause injury. The tool can be hung by the bracket below the engine or by drive shaft housing.
46. Store tool out of reach of children.

If situations occur which are not covered in this manual, use care and good judgment. Contact your Authorized Service Dealer if you need assistance.

KNOW YOUR UNIT

A. INTRODUCTION

Your Trimmer is a versatile product developed for large lawns and to make short work of a variety of lawn care tasks — trimming, scalping, mowing, and sweeping.

Special Features Include:

- ComforTouch® Anti-vibration System
- All-Position Carburetor
- Sensorfeed™ Cutting Head
- 18" Cutting Path
- 8 Inch, 4 Point Weed Blade
- Shoulder Strap w/Warning Decal
- Barrier Handlebar

B. UNPACKING INSTRUCTIONS

1. After removing the contents from the carton, check the parts against the list.
2. Examine the parts for damage. Do not use damaged parts.
3. Notify your WEED EATER dealer immediately if a part is missing or damaged.

NOTE: It is normal to hear the fuel filter rattle in an empty fuel tank.

C. CARTON CONTENTS

KEY NO.	(QTY)
1. Engine	1
2. Drive Shaft/Bearing Housing Assembly w/Safety Label	1
3. Handlebar	1
4. Plastic Shield - Trimmer Head	1
5. Trimmer Head	1
* 6. Metal Shield - Blade	1
* 7. Weed Blade - 8 inch, 4 point	1
8. Shoulder Strap w/Warning	1
— Operator's Manual (not shown)	1
— Loose Parts Bag (not shown)	1

LOOSE PARTS BAG CONTENTS:

9. Mounting Block - Handlebar	1
10. Mounting Block Cover - Handlebar	2
11. Grass Washer - Trimmer Head	1
12. Retention Plate - Metal Shield	1
* 13. Shoulder Strap Clamp	1
14. T-Handle - Shoulder Strap Clamp	1
15. Hex Wrench - 5/32"	1
16. Hex Wrench - 3/16"	1
A. Hex Socket Screw - Engine	2
B. Screw - Plastic Shield	4
C. Square Head Screw - T-Handle	1
D. Bolt - Handlebar/Metal Shield	8
* E. Flat Washer - Blade	1
* F. Beveled Washer - Blade	1
* G. Flange Hex Nut - Blade	1
H. Hex Nut - T-Handle	1
I. Lock Nut - Engine	2

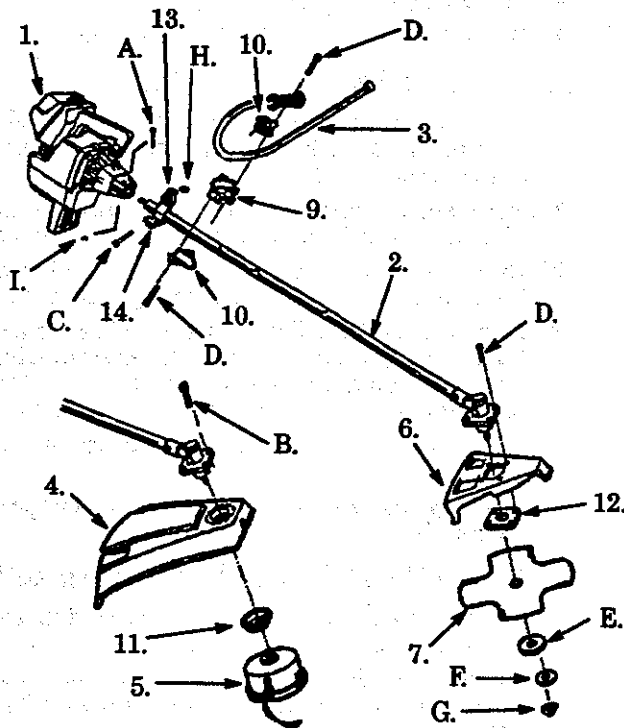

▲ WARNING
Parts marked with * are critical and must be supplied by Weed Eater. Failure to use the proper parts can cause the blade to fly off and seriously injure the operator or others.

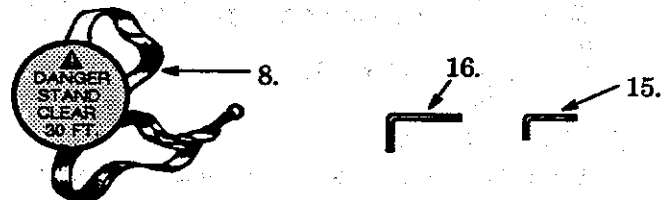

SAFETY NOTICE

Exposure to vibrations through prolonged use of gasoline powered hand tools could cause blood vessel or nerve damage in the fingers, hands, and wrists of people prone to circulation disorders or abnormal swellings. Prolonged use in cold weather has been linked to blood vessel damage in otherwise healthy people. If symptoms occur such as numbness, pain, loss of strength, change in skin color or texture, or loss of feeling in the fingers, hands, or wrists, discontinue the use of this tool and seek medical attention. An anti-vibration system does not guarantee the avoidance of these problems. Users who operate power tools on a continual and regular basis must monitor closely their physical condition and the condition of this tool.

ASSEMBLY

(If tool is received assembled, repeat all steps in this section to be sure assembly is correct and is adjusted for the operator.)

A. PREPARATION

This Operator's Manual has been developed to help you assemble the tool and to provide its safe operation. It is important that you read the entire manual to become familiar with the tool *before* you begin assembly.

1. Read your Operator's Manual

2. Tools you will need:

- Hex Wrench(s) provided with tool
- Adjustable Wrench
- Standard Screwdriver

B. HARDWARE USAGE

Refer to the Hardware reference letters below during assembly.

NOTE: This Hardware is packaged in the Plastic Bag.

(HARDWARE SHOWN ACTUAL SIZE)

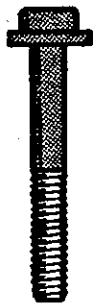

A.
Shroud
Screw



B.
Screw-
Plastic
Shield

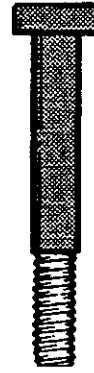

C.
Square
Head
Screw



D.
Screw-
Metal Shield and
Handlebar Clamp

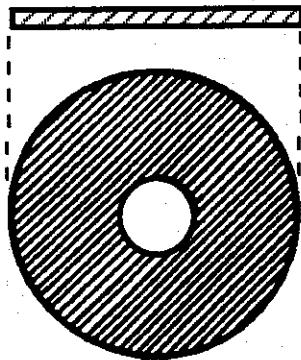

E.
Flat Washer

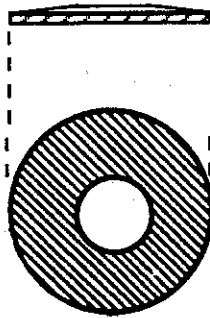

F.
Beveled Washer

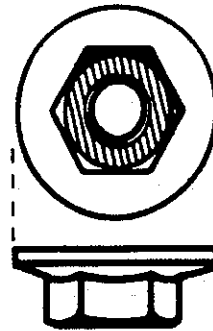

G.
Flange Hex Nut



H.
Lock Nut



I.
Lock Nut

Figure 1

C. ASSEMBLY STEPS

1. DRIVE SHAFT HOUSING (Figure 2)

- Place the two Screws "A." into the holes on the Clutch Shroud as shown in Figure 2.
- Position the Lock-Nuts "I." in the hex opening in the Clutch Shroud.
- Tighten the screws with the 5/32" hex wrench (provided) just enough to hold the hardware together while holding the lock-nuts with your other hand.
- Remove the packing cover from the Drive Shaft Housing if so equipped.

NOTE: Make sure the Flexible Drive Shaft does not fall out of the Drive Shaft Housing. Dirt on the

Shaft will significantly reduce the life of the tool. If the Flexible Drive Shaft falls out of the Housing, clean, re-lubricate, and re-install. See "Flexible Drive Shaft Lubrication" in the Maintenance section of this manual.

- Align the bottom groove on the Drive Shaft Housing with the ridge on the inner, lower wall of the Clutch Shroud opening. Figure 2.
- Turn the Arbor Shaft as necessary to align the square end of the Flexible Drive Shaft with the square inside the Clutch Shroud opening.
- Firmly push the Drive Shaft Housing into the Clutch Shroud opening until it bottoms out (about 1 1/2 inches).
- Tighten Screws "A." alternately until secure. Figure 2.

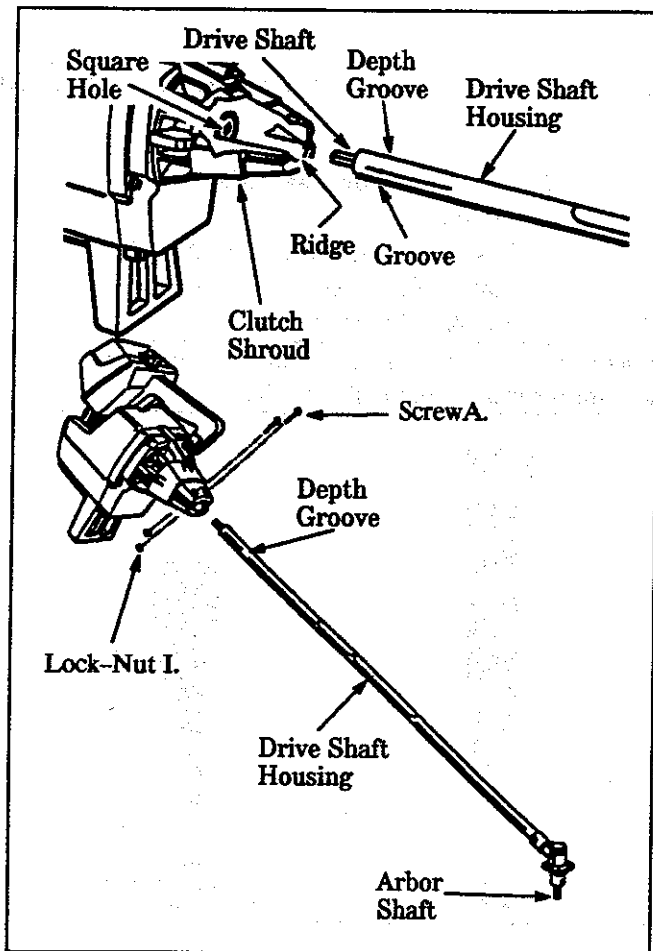

Figure 2

2. HANDLEBAR

▲ WARNING

The handlebar mounting block must be placed above the point of the arrow on the safety labels. The handlebar is a barrier to keep the blade away from the operator's feet.

- Position the Mounting Block on the Drive Shaft Housing above the arrow on the Safety Labels. Figure 3.
- Align the Handlebar with the straight barrier portion to the left and the curved portion to the right as shown in Figure 3.
- Position the short, straight section of the Handlebar in the Mounting Block.
- Place the two Covers as shown in Figure 3.
- Install the four screws "D." one at a time into the clamp assembly and tighten just enough to hold the parts together.
- Position the Handlebar for height as shown in Figure 4.
- Be sure the Handlebar is installed correctly, then tighten each screw securely with the large hex wrench. Figure 3.

▲ WARNING

The Barrier Portion of the Handlebar must be installed as shown in Figure 3 to provide a barrier between the operator and the spinning blade.

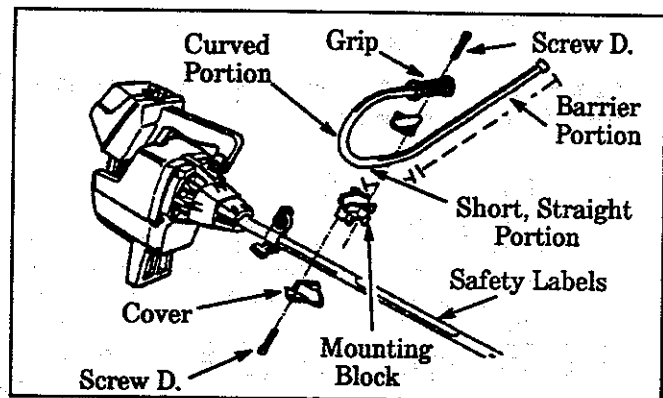
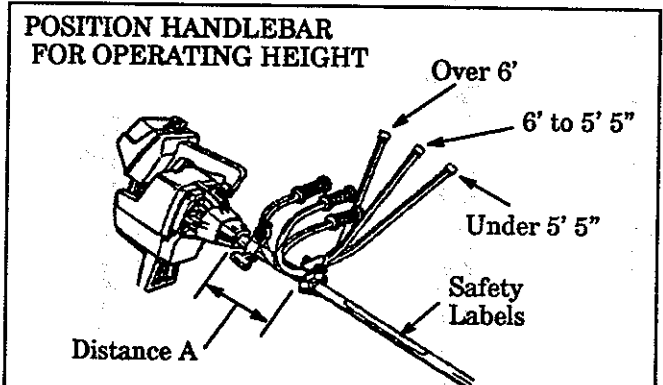

Figure 3



Operator's Height	Distance A
Less than 6 feet	4 inches
6 feet & over	2 inches

Figure 4

3. FOR LINE TRIMMER USE

▲ WARNING

The plastic shield must be properly installed for all line trimmer usage. The plastic shield provides partial protection from the risk of thrown objects to the operator and others and is equipped with a line limiter which cuts excess line to the proper length.

▲ WARNING

Failure to install the shield in the position shown in Figure 5 can result in serious injury to the operator. The length of the shield must be aligned with the length of the drive shaft housing. Direct the widest part of the shield toward the engine.

NOTE: If your unit is equipped as a blade trimmer, remove the Metal Shield and Blade before installing the Plastic shield and Trimmer Head.

- Remove the packing cover from the Arbor Shaft (if so equipped), then remove the dust cup.
- Place the Shield under the Gear Box and align screw holes. Figure 5.

CAUTION: The line limiter (on the underside of the shield) is sharp and can cut you.

- Insert the four Plastic Shield Screws "B." (one at a time) through the Gear Box into the shield.
- Tighten the Screws evenly and securely.

- e. Install the Dust Cup and Grass Washer over the Arbor shaft. Make sure the Grass Washer is against and curved over the dust cup. Figure 5 .
- f. Start threading the Trimmer Head onto the Arbor Shaft as shown in Figure 5 .
- g. Align the hole in the Dust cup with the hole in the center front of the Gear Box by turning the Dust Cup.
- h. Insert the small hex wrench (provided) into the aligned holes to keep the Arbor Shaft from turning. Figure 5 (inset).
- i. Tighten the Trimmer Head against the Washer and Dust Cup while holding the hex wrench.
- j. Remove the hex wrench.

NOTE: To remove the Trimmer Head, insert the hex wrench into the aligned holes in the Dust Cup and Gear Box. Unthread the Trimmer Head. Be sure to store the Grass Washer, Plastic Shield, 4 Shield Screws, and Hardware with the Trimmer Head for future use.

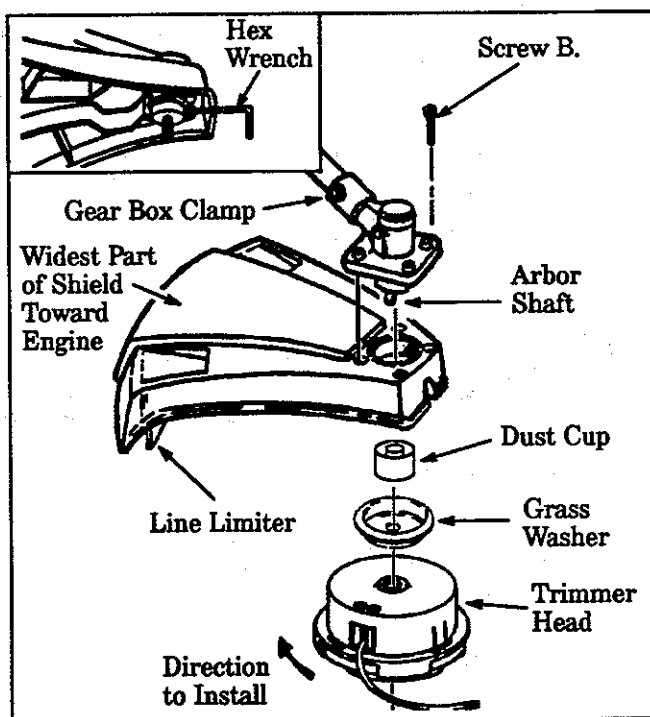

Figure 5

4. SHOULDER STRAP CLAMP

- a. Align Shoulder Strap Clamp between Handlebar Mounting Block and Engine. Figure 6 .
- b. Firmly push the Shoulder Strap Clamp onto the Drive Shaft Housing. Figure 6 . Be sure that the Shoulder Strap Clamp is installed with the hex shaped recession (on the clamp) facing the same side of the Drive Shaft Housing as the Barrier Portion of the Handlebar.
- c. Drop the threaded end of the square-head T-Handle Screw "C." through the opening in the top of the T-Handle. Figure 7 .
- d. Pull on the threaded end of the Screw to bring the square head of the Screw past the pin inside the T-Handle. Figure 7 .
- e. Seat the Nut "H." in the hex-shaped recession on the back side of the Shoulder Strap Clamp.
- f. Insert the threaded end of the T-Handle screw through the hole in the Shoulder Strap Clamp and tighten firmly by hand only.

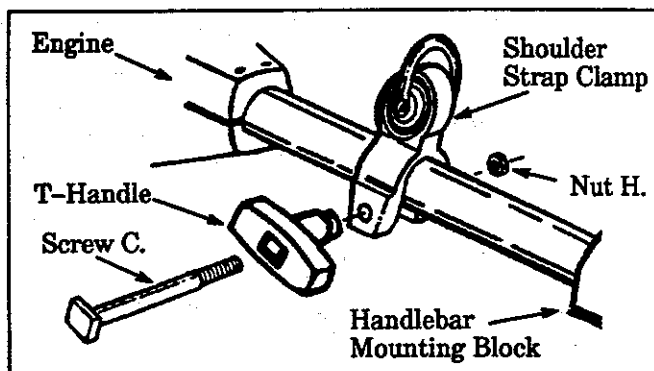

Figure 6

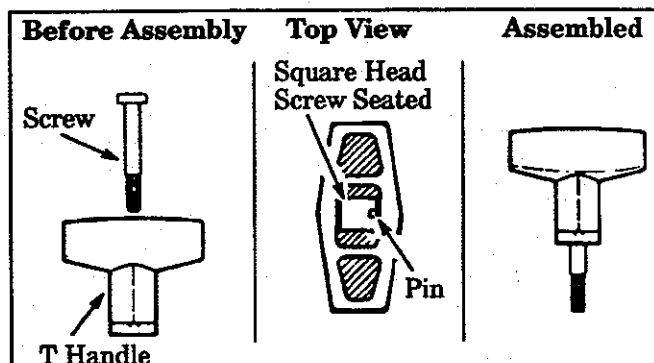

Figure 7

5. SHOULDER STRAP

⚠ WARNING

Proper shoulder strap and handlebar adjustments before starting the engine are required for safe and efficient use.

- a. Try on Shoulder Strap and adjust for fit and balance before starting the engine and beginning a cutting operation.
- b. Place Shoulder Strap on your left shoulder with the Danger Sign on your back and hook to the right side of your waist. Figure 8 .

NOTE: A one-half twist is built in the shoulder strap to allow the strap to rest flat on the shoulder.

- To make sure the strap rests flat on your body, place the double portion across your front and the single portion across your back.
- c. Adjust the Strap so that the hook will be about 10 inches below the waist when the hook is attached to the Shoulder Strap.
 - d. Fasten the Shoulder Strap hook to the clamp and lift the tool to the operating position. Figure 8 .
 - e. Check for the following:
 1. Left arm extended, hand holding handlebar grip.
 2. Right hand holding Top Handle, fingers on Throttle Trigger.
 3. Engine below waist level.
 4. Shoulder Strap pad centered on left shoulder.
 5. Danger sign centered on your back.
 6. Full weight of tool on left shoulder.
 7. Without operator bending over, the Blade or Trimmer Head is near and parallel to the ground and easily contacts material to be cut.

- f. Modify these initial adjustments as necessary for comfort and control but do not locate the Handlebar Mounting Block below the point of the arrow on the Safety Labels. Do not locate the Shoulder Strap Clamp in any position other than between the Engine and Handlebar Mounting Block.



Figure 8

6. FOR WEED BLADE USE

▲ DANGER

The metal shield and metal handlebar must be properly installed on the tool anytime the tool is used with the blade. The forward tip on the metal shield helps to reduce the occurrence of blade thrust which can cause serious injury such as amputation to the operator or bystanders.

▲ WARNING

Failure to install the shield in the position shown in Figures 9 and 8 can result in serious injury to the operator. The length of the shield must be aligned with the length of the drive shaft housing. Direct the widest part of the shield toward the engine.

NOTE: If your unit is equipped as a line trimmer, remove the trimmer head and plastic shield before installing the metal shield and blade. Be sure to store parts for future use.

- Remove the packing cover from the Arbor Shaft if so equipped.
- Install the Dust Cup over the Arbor Shaft.
- Position the Retention Plate on the underside of the Metal Shield and align screw holes. Make sure the flat side of the Plate is against the shield.
- Hold the Retention Plate in position and place the metal Shield under the Gear Box. Align screw holes. Figure 9.
- Insert the four Metal Shield Screws "D." (one at a time) through the Gear Box, Shield, and Retention Plate. Figure 9.

- Tighten the Screws evenly and securely with a hex wrench.
- Install the Blade over Arbor Shaft, making sure the hole in the center of the Blade is fitted around the raised center step on the Dust Cup. Figure 9.
- Install the large Flat Washer "E.", Beveled Washer "F.", and Hex Flange Nut "G." as shown in Figure 9. Be sure Beveled Washer "F" is installed as shown in Figure 9 (inset).
- Align the hole in the Dust Cup with the hole in the side of the Gear Box by turning the Arbor Shaft. Figure 9.
- Insert the large hex wrench (provided) into the aligned holes to keep the Arbor Shaft from turning. Figure 9 (inset, upper left).
- Tighten the Hex Flange Nut firmly with a wrench while holding hex wrench in position.
- Remove the hex wrench.
- Turn Blade by hand. If the Blade binds against the Shield, the Blade is not centered. Reinstall the Blade.
- Proceed to "Shoulder Strap" instructions, this section.

NOTE: To remove the Blade, insert the large hex wrench into aligned holes. Un-thread the Hex Flange Nut and remove parts. Be sure to store the Retention Plate, hex Flange Nut, Beveled Washer, Flat Washer, 4 Shield Screws, and Metal Shield with the Blade for future use.

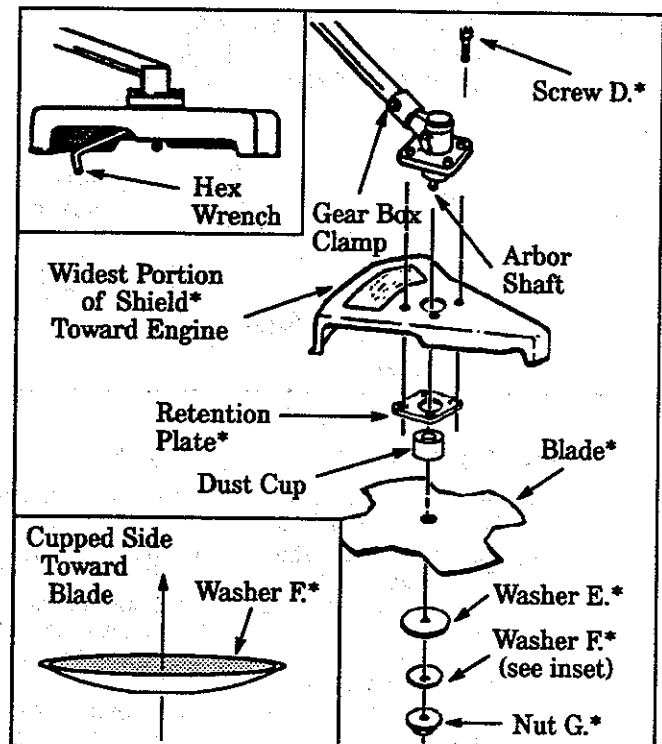

Figure 9

▲ WARNING

Parts noted with * are critical and must be supplied by Weed Eater. Failure to use proper parts can cause the blade to fly off and seriously hurt you or others.

ENGINE INFORMATION

A. FUELING YOUR ENGINE

1. FUEL SAFETY

- a. Use only recommended fuel mixtures.
- b. Mix and pour fuel outdoors and where there are no sparks or flames.
- c. Use a container approved for fuel.
- d. Do not smoke or allow smoking near fuel or the tool or while using the tool.
- e. Wipe up all fuel spills before starting the engine.
- f. Move at least 10 feet (3 meters) away from fueling site before starting engine.
- g. Stop engine before removing fuel cap.
- h. Empty fuel tank before storing tool. Use up fuel left in carburetor by starting engine and letting engine run until it stops.
- i. Store tool and fuel in an area where fuel vapors cannot reach sparks or open flames from water heaters, electric motors or switches, furnaces, etc.

2. FUEL MIXTURE

- a. Your tool is powered by a two-cycle engine which requires a fuel mixture of regular unleaded gasoline and a high quality engine oil specially made for 2-cycle, air cooled engines.
The internal design of the 2-cycle, air cooled engine requires lubrication of moving parts. Lubrication is provided when the recommended mixture of gasoline and oil is used.
- b. Genuine Poulan, Poulan Pro, or Weed Eater 40:1, 2-cycle air-cooled engine oil is strongly recommended for the protection of your unit. Extensive engineering tests have proven that Poulan, Poulan Pro, or Weed Eater 2-cycle air-cooled engine oil resists break-down at operating temperatures common to 2-cycle engines, resulting in dependable performance and longer engine life.
- c. Gasoline must be clean and not over two months old. After a short period of time, gasoline will chemically break down and form compounds that cause hard starting and damage in 2-cycle engines.

- d. The correct measure of gasoline to oil is very important. Too much oil in the mixture will foul the spark plug.

CAUTION: Too little oil or incorrect oil will cause the engine to overheat and seize.

- e. Always mix the fuel thoroughly in a container since gasoline and oil do not readily combine. Do not mix gasoline and oil directly in the fuel tank.

3. USE THE FOLLOWING:

Poulan, Poulan Pro, or Weed Eater 40:1, 2-cycle air-cooled engine oil is strongly recommended. Any other Poulan, Poulan Pro, or Weed Eater brand 2-cycle air-cooled engine oil is acceptable when mixed according to the instructions on the container.

If Poulan, Poulan Pro, or Weed Eater 2-cycle air-cooled engine oil is not available, use a good quality two cycle, air-cooled engine oil mixed at a ratio of 16:1 (8 oz. oil to 1 gallon gasoline).

4. DO NOT USE:

- a. NMMA OIL (National Marine Manufacturer's Association) formerly BIA oil
Does not have proper additives for air-cooled, 2-cycle engines and can cause engine damage.
- b. AUTOMOTIVE OIL
Does not have proper additives for air-cooled, 2-cycle engines and can cause engine damage.

5. HOW TO MIX FUEL AND FILL TANK

- a. Pour the proper measure of engine oil into an approved, marked container. Do not mix gasoline and oil directly in the fuel tank.
- b. Using a spout or funnel, fill the tank with regular unleaded gasoline.
- c. Reinstall the fuel cap securely.

NOTE: If fuel is already in the fuel container, add the proper measure of engine oil. Then, close the container tightly and shake it momentarily.

B. PRE-OPERATION CHECKS

▲ WARNING

Review all Warnings and Safety Instructions in this manual.

1. Before operating your tool, always:

- a. Inspect the entire tool before each use. Replace damaged parts. Check for fuel leaks and make sure all fasteners are in place and securely fastened.
- b. Throw away blades that are bent, warped, cracked, broken, or damaged in any other way. Replace trimmer head parts that are cracked, chipped, or damaged before using the tool.
- c. Use only Weed Eater .080" diameter Weed Line. Never use wire, rope, string, etc.
- d. Use only with the correct shield properly attached.

- e. Use only the specified blade or trimmer head. See "Specifications." Make sure the trimmer head is properly installed and securely fastened. Refer to "Assembly."
- f. Be sure blade or trimmer head stops turning when engine idles. See "Carburetor Adjustments."
- g. Make carburetor adjustments with the drive shaft housing supported to prevent the blade or trimmer line from contacting any object. Hold the tool by hand; do not use shoulder strap for support.
- h. Keep others away when making carburetor adjustments.
- i. Use only genuine Weed Eater accessories or attachments recommended for this tool.
- j. Clean air filter if dirty before operating tool. Refer to "Specifications," for air filter location.

C. STARTING INSTRUCTIONS

(For location of controls, refer to "Specifications.")

1. Before starting the Engine:

- Fuel engine. Move 10 feet (3 meters) away from fueling site.
- When using your unit as a line trimmer, extend line approximately 4 inches from trimmer head to provide adequate load on engine.

▲ DANGER

The blade or trimmer head will turn while starting engine.

- Rest Engine and Shield on ground, supporting blade or trimmer head off ground away from trees, bushes, onlookers, etc. Figure 10 .
 - When using a blade, place the shoulder strap on your shoulder. *Start engine before lifting tool to operating position or clipping Shoulder Strap to tool.*
- ### 2. For a Cold Engine or a Warm Engine after running out of fuel:
- Move Ignition switch to "On." Figure 11 .
 - Move Choke to "full" position. Figure 12 .
 - Grasp top handle and squeeze throttle trigger fully. *Keep throttle trigger fully squeezed until engine runs smoothly (through step "g.")*
 - Pull starter rope sharply until engine attempts to run, but no more than 8 pulls at full choke to avoid flooding the engine. **The "attempt to run" may be hard to hear. The operator must listen carefully.** After 8 pulls, proceed to step "e." even if the engine has not attempted to run.
 - Move Choke to "half" position. Figure 12 .
 - Pull the Starter Rope sharply until the engine runs, but no more than 5 pulls.

NOTE: If the engine does not start after 5 pulls, repeat steps "a." through "f."

- Allow engine to run 5 seconds, then push Choke to "off" position. Figure 12 . *Keep Throttle Trigger squeezed until engine runs smoothly.*

NOTE: If engine dies with Choke at "off" position, repeat steps "e." through "g."

NOTE: If engine does not start, pull Starter Rope 5 more pulls. If engine still does not run, it is probably flooded. Wait a few minutes and repeat procedure with Choke at "off" position. Figure 12 .

▲ WARNING

Avoid any bodily contact with the muffler when starting a warm engine. A hot muffler can cause serious burns.

3. For a Warm Engine:

- Move ignition switch to "On." Figure 11 .
- Move choke lever to the "Off" position.
- Grasp top handle and squeeze throttle trigger fully.
- Pull Starter Rope sharply until engine runs, but no more than 5 pulls. *Keep Trigger fully squeezed until engine runs smoothly.*

NOTE: If engine does not start after 5 pulls, it is probably flooded. Wait a few minutes and repeat procedure with Choke at "off" position. Figure 12 .

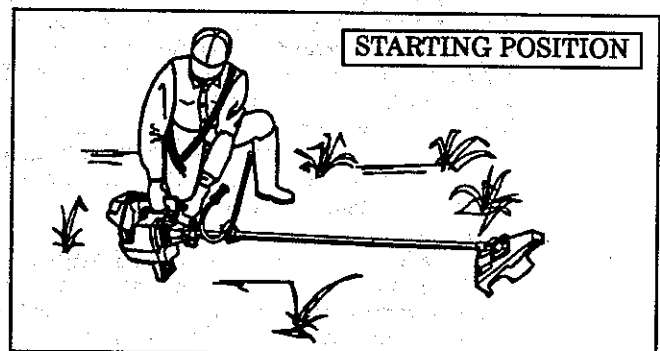

Figure 10

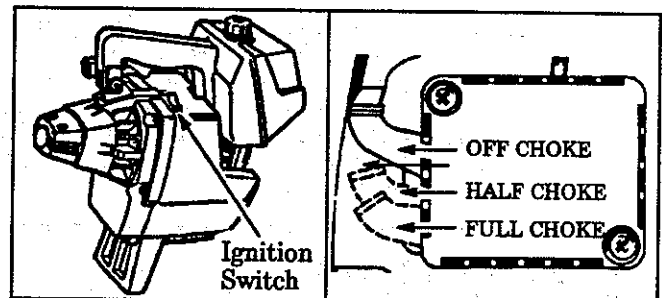

Figure 11

Figure 12

NOTES

D. OPERATING INSTRUCTIONS

1. **When using the Blade**, bring the engine to full throttle before entering the material to be cut. The Blade has maximum cutting power at full throttle and is less likely to bind, stall, or cause blade thrust, which can result in serious injury to the operator or others. Refer to the "Guard Against Blade Thrust" section.
2. **When using the Trimmer Head**, do not run the engine at a higher speed than necessary. The cutting line will cut efficiently when the engine is run at less than full throttle. At lower speeds, there is less engine noise and vibration. The cutting line will last longer and will be less likely to "weld" onto the spool.
3. **If the Blade or Trimmer Head does not turn when the engine is accelerated**, make sure the Drive Shaft Housing is properly seated in the Engine Shroud. Refer to the "Assembly-Drive Shaft Housing" section.
4. **Always release the Throttle Trigger and allow engine to return to idle speed when not cutting.**
5. **The Blade or Trimmer Head must not turn when the engine runs at idle speed.** If the Blade or Trimmer Head on your unit turns when the engine is at idle speed, refer to the "Trouble Shooting Chart."
6. **To stop engine:**
 - a. Release the Throttle Trigger.
 - b. Move Ignition Switch to the "Off" position. Figure 11.

- c. Stop the blade by allowing the "9 o'clock" position to contact cut material. Figure 13 (inset).

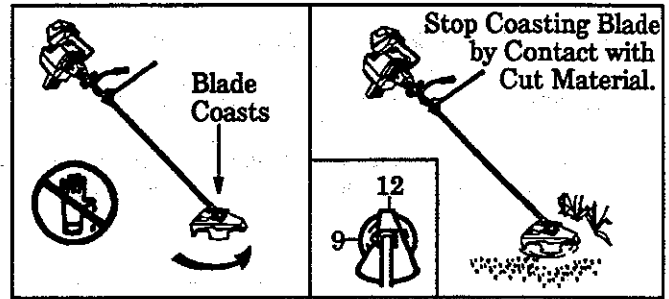

Figure 13

▲ WARNING

The blade continues to spin after the engine is turned off. The coasting blade can throw objects or seriously cut you if accidentally touched. Stop the blade by contacting the left-hand side of the coasting blade with material already cut.

▲ WARNING

Stop engine and blade before removing materials wrapped around the blade shaft to avoid injury.

▲ WARNING

The operator or others must not try to clear away cut material with the engine running or the blade turning to avoid serious injury.

NOTES

USING YOUR TOOL AS A WEEDCUTTER

(The 8 inch Weed Blade is designed to cut grass, weeds and woody brush up to 1/2 inch diameter.)

▲ DANGER - THIS POWER TOOL CAN BE DANGEROUS!

This tool can cause serious injury including amputation or blindness to the operator and others. The warnings and safety instructions in this manual must be followed to provide reasonable safety and efficiency in using this tool. The operator is responsible for following the warnings and instructions in this manual and on the tool. **Read the entire Operator's Manual before using this tool! Restrict the use of this power tool to persons who read, understand and follow the warnings and instructions in this manual and on the tool.**

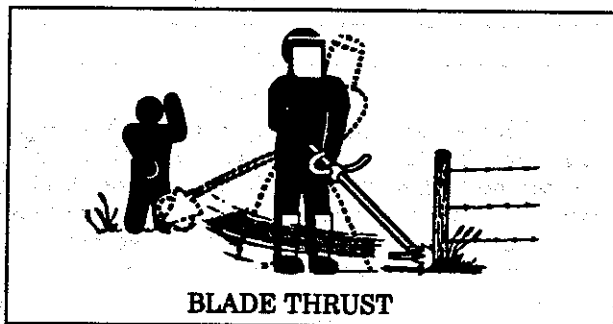

BLADE THRUST

▲ **DANGER - BLADE THRUST** When the spinning blade contacts anything it cannot cut, a dangerous reaction can occur causing the entire tool and operator to be thrust violently in any direction. This reaction is called *Blade Thrust*. As a result, the operator can lose control of the tool. **Use handlebar, shoulder strap, and keep shield in place. Make sure others are at least 30 feet (10 meters) away. Keep blade sharp. Cut at full throttle and from your right to left. Keep hands, feet and tool in proper position; refer to "Guard Against Blade Thrust."**

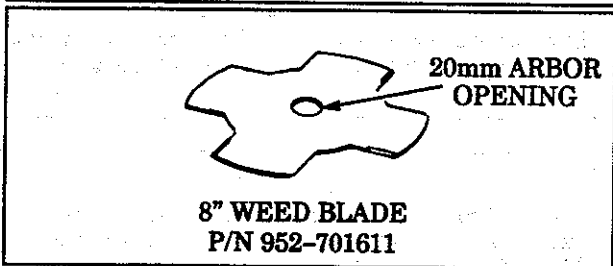

8" WEED BLADE
P/N 952-701611

▲ DANGER - PROPER BLADE

Use only the 4 point, 8 inch Weed Blade and proper hardware as shown. The use of any other parts can result in serious injury. **Do not use any accessory or attachment other than those recommended by the manufacturer for use with this tool.** Blades that are bent, warped, cracked, broken, or damaged can fly apart and cause serious injury. **Do not use. Throw away.**

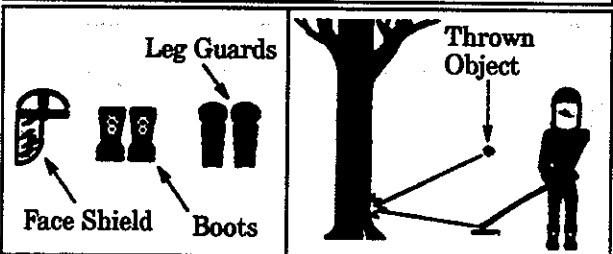

▲ WARNING - THROWS OBJECTS

The rapidly moving blade causes objects to be thrown violently. The shield will not provide complete protection to the operator or others. The operator must wear a safety face shield or goggles. Always wear safety leg guards and boots. Keep others at least 30 feet away.

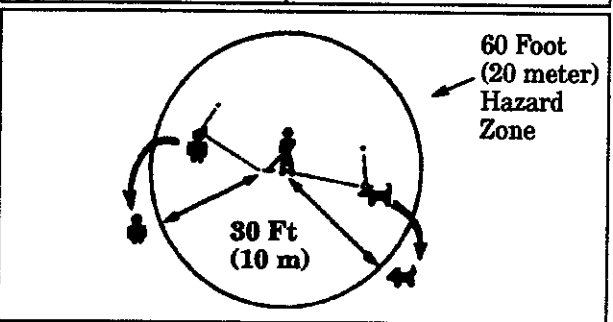

▲ WARNING - HAZARD ZONE

This tool will throw objects and cut. **Keep others including children, animals, bystanders, and helpers at least 30 feet (10 meters) away from the operator and tool. Stop the engine and blade immediately if you are approached.**

NOTE: In areas where other people and animals are present, such as near sidewalks, streets, houses, etc., it is strongly recommended that the operator use the buddy system; that is, have another person serve as a "look out," keeping himself and others at least 30 feet (10 meters) away from the operator.

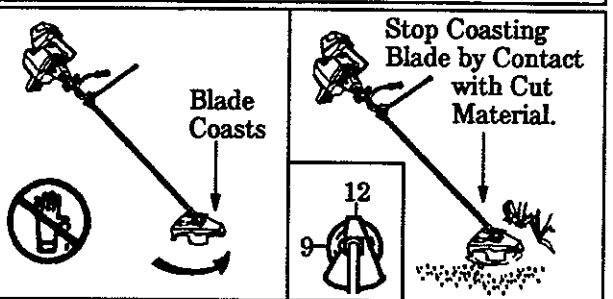

▲ WARNING - COASTING BLADE

The blade continues to spin after the engine is stopped or the throttle is released. The coasting blade can thrust, throw objects, or seriously cut you if accidentally touched. **Stop the blade by leaving it in contact with material already cut. Use the "9 o'clock" position as the point of contact.**

A. BLADE SAFETY

1. OPERATOR

- a. Always wear a safety face shield or goggles. See "Accessories."
- b. Always wear heavy, long pants, boots, gloves and safety leg guards. See "Accessories." Do not wear loose clothing, jewelry, short pants, sandals or go barefoot. Secure hair so it is above shoulder length.
- c. Do not operate this tool when you are tired, ill or under the influence of alcohol, drugs or medication.
- d. Always use the handlebar and a properly adjusted shoulder strap. See "Assembly."
- e. Do not swing the tool with such force that you are in danger of losing your balance.
- f. Never start or run the engine inside a closed room or building. Breathing exhaust fumes can kill.
- g. Keep handles free of oil and fuel.

2. TOOL

- a. Inspect the entire tool before each use. Replace damaged parts. Check for fuel leaks and make sure all fasteners are in place and securely fastened.
- b. Be sure the metal shield is properly attached. The metal shield *must* be installed for all blade usage.

- c. Make sure the blade is properly installed and securely fastened. Refer to "Assembly."
- d. Be sure the blade stops turning when the engine idles. See "Trouble Shooting Chart."
- e. Make carburetor adjustments with the drive shaft housing supported to prevent the blade from contacting any object. Hold tool by hand; do not use the shoulder strap for support.
- f. Keep others away when making carburetor adjustments.

3. CUTTING

- a. Inspect the area to be cut before each use. Remove objects (rocks, broken glass, nails, wire, string, etc.) which can be thrown or become entangled in the blade.
- b. Always keep the engine on the right side of your body. Hold the tool firmly with both hands.
- c. Keep firm footing and balance. Do not over-reach.
- d. Keep blade below waist level.
- e. Do not raise the engine above your waist. The blade can come dangerously close to your body.
- f. Cut at full throttle.
- g. Cut from your right to left.
- h. Use only for jobs explained in this manual. Do not use the blade as an edger. The shield does not provide adequate protection.

B. GUARD AGAINST BLADE THRUST

- *Blade Thrust* is a reaction that only occurs when using a bladed tool. This reaction can cause serious injury such as amputation. Carefully study this section. It is important that you understand what causes *blade thrust*, how you can reduce the chance of *blade thrust* occurrence, and how you can remain in control of the tool if *blade thrust* occurs.
- The forward tip on the shield helps to reduce the occurrence of *blade thrust* but cannot prevent the occurrence. The operator must follow the warnings and safety instructions in this section to lessen the chance of *blade thrust* occurring and to maintain control of the tool if the reaction does occur.

1. **WHAT CAUSES BLADE THRUST?** *Blade Thrust* can occur when the spinning blade contacts an object that it cannot cut. This contact causes the blade to stop for an instant and then suddenly move or "thrust" away from the object that was hit. The "thrusting" reaction can be violent enough to cause the operator to be propelled in any direction and lose control of the tool. The uncontrolled tool can cause serious injury if the blade contacts the operator or others. Figure 14.

2. **WHEN BLADE THRUST OCCURS.** *Blade thrust* can occur without warning if the blade snags, stalls, or binds. This is more likely to occur in areas where it is difficult to see the material being cut. By using the tool properly, the occurrence of *blade thrust* will be reduced and the operator will be less likely to lose control.

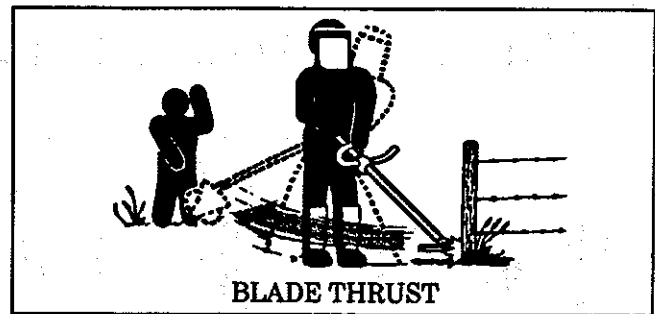

Figure 14

3. REDUCE THE CHANCE OF BLADE THRUST.

- a. Cut only grass, weeds and woody brush up to 1/2 inch diameter. Do not let the blade contact material it cannot cut such as stumps, rocks, fences, metal, etc., or clusters of hard, woody brush having a diameter greater than 1/2 inch.
- b. Keep the blade sharp. A dull blade is more likely to snag.
- c. Cut only a full throttle. The blade has maximum cutting power at full throttle and is less likely to bind or stall.
- d. "Feed" the blade deliberately and not too rapidly. The blade can thrust away if it is fed too rapidly.
- e. Cut only from your right to left. Swinging the tool in the same direction as the blade spins increases the cutting action.

4. MAINTAIN CONTROL

- a. Use the shoulder strap and keep a firm grip on the tool with both hands. A properly adjusted shoulder strap will support the weight of the tool, freeing your arms and hands to control and guide the cutting motion.
- b. Keep feet comfortably spread apart and braced for the possibility of a sudden, rapid thrust of the tool. Do not overreach. Keep firm footing and balance.
- c. Keep the blade below waist level. It will be easier to maintain control of the tool.
- d. Do not raise the engine above your waist as the blade can come dangerously close to your body.
- e. Do not swing the tool with such force that you are in danger of losing your balance.

C. CUTTING METHODS

1. Establish a rhythmic cutting procedure.
 - a. Plant feet firmly, comfortably apart.
 - b. Cut while swinging the upper part of your body from right to left.
 - c. Move forward to the next area to be cut after the return swing and plant feet once more.
2. Use the 8 o'clock to 10 o'clock position for cutting. Figure 15.
3. Stop the engine and blade, then unclip the shoulder strap from the tool before clearing cut material.
4. To reduce the chance of material wrapping around the blade, follow these steps:
 - a. Cut at full throttle.
 - b. Swing the tool into material to be cut from your right to left.
 - c. Avoid the material just cut as you make the return swing.

▲ WARNING
Stop engine and blade before removing materials wrapped around the blade shaft to avoid injury.

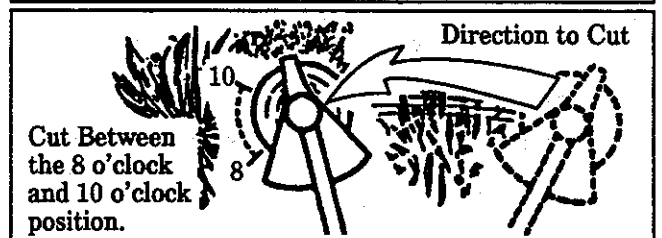
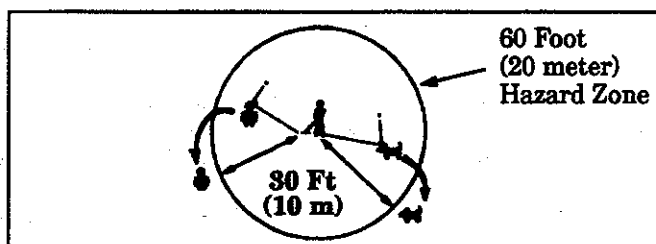
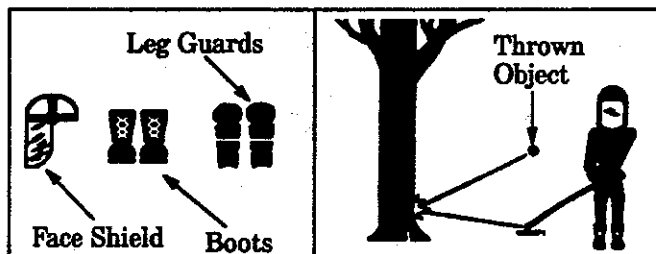

Figure 15

▲ WARNING
The operator or others must not try to clear away cut material with the engine running or the blade turning to avoid serious injury.

USING YOUR TOOL AS A LINE TRIMMER



▲ WARNING—THROWS OBJECTS
The rapidly moving line causes objects to be thrown violently. The shield will not provide complete protection to the operator or others. The operator must wear a safety face shield or goggles. Always wear heavy, long pants and boots. Keep others at least 30 feet (10 meters) away.

▲ WARNING – HAZARD ZONE
This tool will throw objects and cut. Keep others including children, animals, bystanders and helpers at least 30 feet (10 meters) away from the operator and tool. Stop the engine if you are approached.

▲ WARNING – DAMAGED TRIMMER HEAD
Trimmer head parts that are chipped, cracked or damaged in any other way can fly apart and cause serious injury. Do not use. Replace damaged parts before using the tool.

A. TRIMMER SAFETY

1. OPERATOR

- Always wear a face safety shield or goggles. See "Accessories."
- Always wear heavy, long pants, boots, and gloves. See "Accessories." Do not wear loose clothing, jewelry, short pants, sandals or go barefoot. Secure hair so it is above shoulder length.
- Do not operate this tool when you are tired, ill or under the influence of alcohol, drugs or medication.
- Do not swing the tool with such force that you are in danger of losing your balance.
- Never start or run the engine inside a closed room or building. Breathing exhaust fumes can kill.
- Keep handles free of oil and fuel.

2. TOOL

- Inspect the entire tool before each use. Replace damaged parts. Check for fuel leaks and make sure all fasteners are in place and securely fastened.
- Use only .080" diameter WEED LINE. Never use wire or rope, string, etc.
- Be sure the plastic shield is properly attached. The plastic shield *must* be installed for all line trimmer usage.
- Make sure the trimmer head is properly installed and securely fastened. Refer to "Assembly."

- Be sure trimmer head stops turning when engine idles. See "Carburetor Adjustments."
- Make carburetor adjustments with the drive shaft housing supported to prevent the trimmer line from contacting any object. Hold tool by hand; do not use the shoulder strap for support.
- Keep others away when making carburetor adjustments.
- Use only genuine Weed Eater accessories or attachments as recommended.

3. CUTTING

- Inspect the area to be cut before each use. Remove objects (rocks, broken glass, nails, wire, string, etc.) which can be thrown or become entangled in the trimmer head.
- Always keep the engine on the right-hand side of your body.
- Hold the tool firmly with both hands.
- Keep firm footing and balance. Do not over-reach.
- Keep the trimmer head below waist level.
- Do not raise the engine above your waist.
- Keep all parts of your body away from the trimmer line and muffler when the engine is running.
- Use only for jobs explained in this manual.

B. LINE ADVANCE

- The trimmer line advances automatically as the line wears and reduces the cutting path.
- The line will wear faster and will advance more frequently when cutting against hard surfaces such as rocks, bricks, concrete, metal fences, etc., than when cutting against woody objects such as trees or wooden fences.
- If line does not advance properly:
 - Operate the engine at full throttle and allow the line to strike a hard surface such as concrete or the ground.
 - If line is 4" or less, stop the engine and check for line binding or tangling on the spool. See "Trimmer Head" in the Maintenance Section for re-winding instructions.
- Always keep the shield in place when the tool is being operated. Figure 16.

▲ WARNING

Use only .080" diameter WEED LINE. Other sizes of line will not advance properly. Do not use other materials such as wire, string, rope, etc. Wire can break off during cutting and become a dangerous missile that can possibly cause serious injury.

▲ WARNING

Use minimum speed and do not crowd the line when cutting around hard objects (rock, gravel, fence posts, etc), which can damage the trimmer head, become entangled in the line, or be thrown causing a serious hazard.

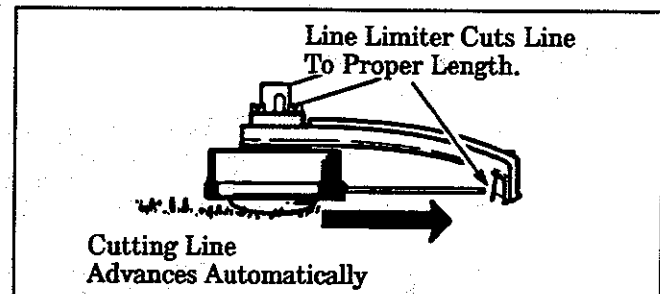

Figure 16

C. CUTTING METHODS

- The tip of the line does the cutting. You will achieve the best performance and minimum line wear by not crowding the line into the cutting area. The right and wrong way are shown in Figure 17.
- The line will easily remove grass and weeds from around walls, fences, trees and flower beds, but it also can cut the tender bark of

trees or shrubs and scar fences. To help avoid damage especially to delicate vegetation or trees with tender bark, use less than full throttle, and keep a 3 inch distance away. Keep in mind that the line will advance suddenly to a longer length when it wears down to 4-5 inches.

- **For trimming or scalping, use less than full throttle to prevent line breakage and excessive line usage, especially:**
 - during light duty cutting.
 - near objects around which the line can wrap such as small posts, trees or fence wire.
- **For mowing or sweeping, use full throttle for a good clean job.**

▲ WARNING

Always wear eye protection. Never lean over the trimmer head. Rocks or debris can ricochet or be thrown into eyes and face and cause blindness or other serious injury.

1. **TRIMMING** - Figure 17 . Hold the bottom of the trimmer head about 3 inches above the ground and at an angle. Allow only the tip of the line to make contact. Do not force the trimmer line into the work area.
2. **SCALPING** - FIGURE 18 . The scalping technique removes unwanted vegetation. Hold the bottom of the trimmer head about 3 inches above the ground and at an angle. Allow the tip of the line to strike the ground around trees, posts, monuments, etc. *This technique increases line wear.*
3. **MOWING**-Figure 19 . Your trimmer is ideal for mowing in places conventional lawn mowers cannot reach. In the mowing position, keep the line parallel to the ground. Avoid pressing the head into the ground as this can scalp the ground and damage the tool.
4. **SWEEPING**- Figure 20 . The fanning action of the rotating line can be used for a quick and easy clean up. Keep the line parallel to and above the surfaces being swept and move the tool from side to side.

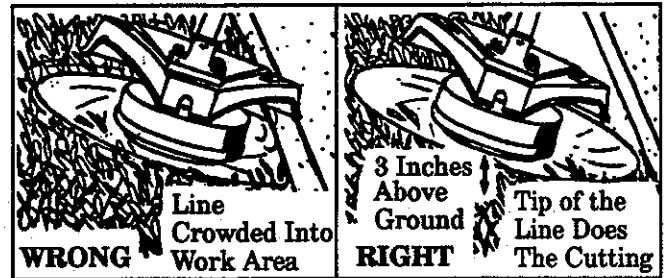

Figure 17

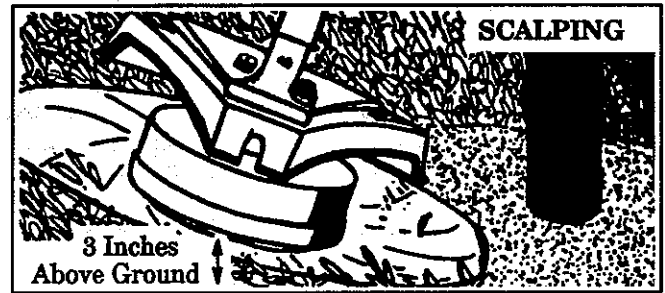

Figure 18

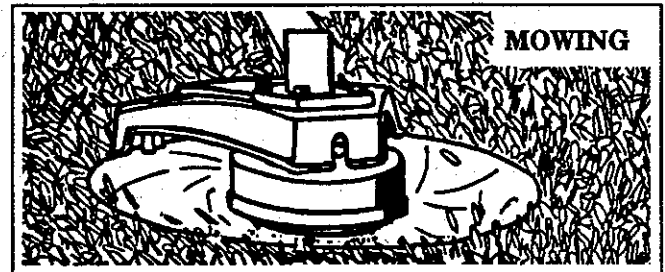

Figure 19

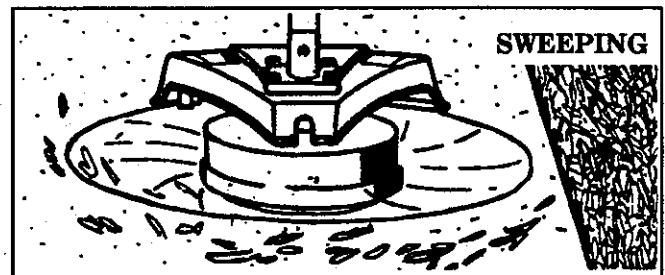

Figure 20

D. LINE REPLACEMENT

- **For proper line feed:**
 - Use only genuine Weed Eater pre-wound spools and .080" diameter WEED LINE. Use of other types of spools or lines can result in excessive breakage, line welding and improper line feed.
 - Pre-wound spools offer the most convenient method for replacing line as well as optimum performance.
- **Always clean dirt and debris from the spool and hub when performing any type maintenance.**

1. Installing Spool w/Line

- a. Hold the Trimmer Head as shown in Figure 21 . Press the Lock Tab and turn Cover counter-clockwise.
- b. Remove the Cover and Spool. Figure 22 .
- c. Clean dirt and debris from all parts.

▲ WARNING

Trimmer head parts that are chipped, cracked or damaged in any way can fly apart and cause serious injury. Do not use. Replace damaged parts before using the tool.

- d. Inspect all Trimmer head parts for damage. Replace damaged parts.
- e. Insert about 6 inches of Line from the inside of the Hub through the Line Exit Hole to the outside to keep the Line from backing into the Head. Figure 23 .
- f. Route the Line behind the Balancing Pin (Figure 23) while carefully placing the Spool in the Hub.
- g. Pull on the Line again from outside the Hub. If the Line can be pulled from the assembled head, it is not properly routed around the Balancing

Pin and will feed continuously when the Trimmer Head turns. Remove Cover and re-route Line as shown in Figure 23 .

h. Reinstall Cover:

- Align the four Catches on the Hub with the cutouts in the Cover. Figure 24 .
- Press the Cover onto the Hub.
- Turn Cover clockwise. Figure 21 .

i. Check to make sure all four Catches and the Lock Tab are properly fastened as shown in Figures 23 & 25 , then test the Cover by trying to turn it counterclockwise.

2. Installing Line on Spool

- a. Follow "Installing Spool w/Line," steps "a.-d."
- b. Remove any Line remaining on the Spool.
- c. Use a 40 foot length of .080" dia. Weed Line.
- d. Insert 1/16" to 1/8" of the end of the Line through one of the holes in the rim of the Spool. Allow no more than 1/8" line to extend beyond the rim to avoid interference with line release action. Figure 25 .
- e. Wind the Line onto the Spool in the direction shown by the arrow on the Spool and as tightly and evenly as possible so the line will feed properly. Figure 25 .

CAUTION: The trimmer head will not function properly if the spool is filled beyond the notches around the outside edge of the spool.

f. Follow "Installing Spool w/Line" steps "e.-g."

▲ WARNING

All four catches must be fastened and the lock tab latched onto the cover. If installed improperly, the cover can fly off and become a dangerous missile.

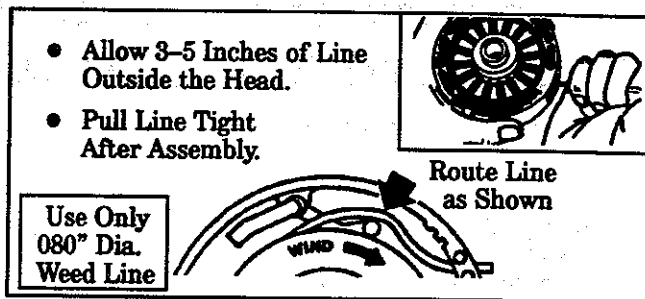

Figure 23

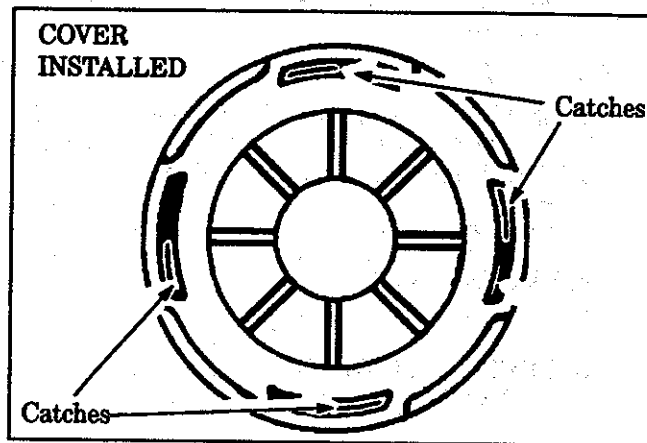

Figure 24

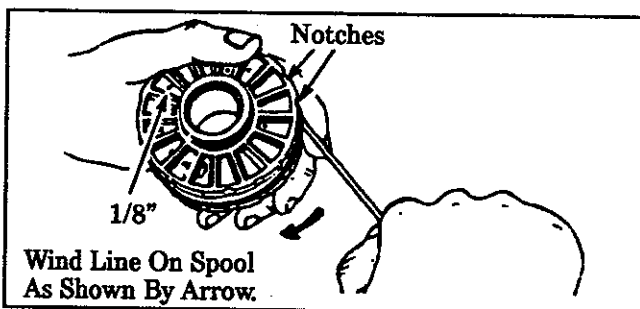

Figure 25

3. Trouble Shooting the Trimmer Line

- **Does not advance, or breaks while cutting:**
 - Improperly routed in head.
 - Improperly wound onto spool.
 - Line size incorrect.
 - Too little line outside head.
- **Pulls back into head:**
 - Too little line outside of head.
- **Welds onto spool:**
 - Line size incorrect.
 - Incorrect spool.
 - Crowding line against material being cut.
 - Cutting at higher speeds than necessary.
- **Releases continuously:**
 - Wound beyond notches on spool.
 - Improperly routed in head.
 - Line size incorrect.
- **Usage is excessive:**
 - Improperly routed in head.
 - Line size incorrect.
 - Cutting at high speeds around hard objects.
 - Crowding line against material being cut.

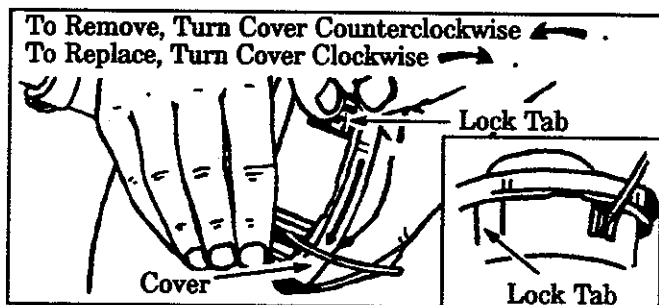

Figure 21

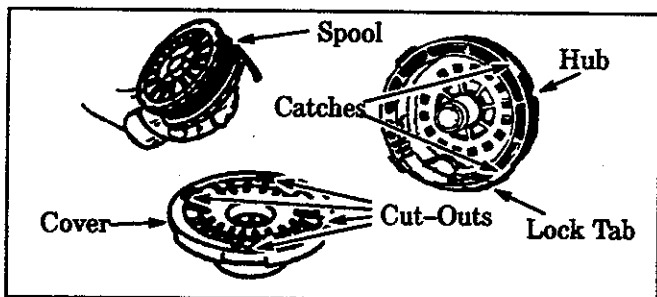

Figure 22

WEED EATER ACCESSORIES

ITEM	STOCK NO.
SAFETY FACE SHIELD	952-701601
SAFETY GLASSES	952-006537
SAFETY LEG GUARDS	952-701600
REPLACEMENT WEED BLADE (8 INCH)	952-701611
WEED EATER 40:1 2-CYCLE ENGINE OIL	
—3.2 oz.	952-030133
—8 oz.	952-030128
FUEL CAP	952-701583
SENSORFEED AUTOMATIC TRIMMER HEAD	952-701608
SENSORFEED REPLACEMENT SPOOL W/LINE	952-701607
REPLACEMENT .080" WEED LINE	
—80 Ft.	952-701534
—200 Ft.	952-701595
—400 Ft.	952-701590
FLEX SHAFT LUBE	952-701570
AIR FILTER	952-701614
SPARK PLUG	530-030077
OPERATOR'S MANUAL	530-067320
ILLUSTRATED PARTS LIST	530-067322

GENERAL MAINTENANCE

A. MAINTENANCE SAFETY

1. Maintain the tool according to recommended procedures. Keep the cutting line at the proper length.
2. Never start the engine with the clutch shroud removed. The clutch can fly apart and cause serious injury.
3. Disconnect the spark plug before performing maintenance except for carburetor adjustments.
4. Make carburetor adjustments with drive shaft housing supported to prevent blade or trimmer line from contacting any object. Hold the tool by hand; do not use the shoulder strap for support.
5. Keep others away when making carburetor adjustments.
6. Be sure blade or trimmer head stops turning when engine idles. See "Carburetor Adjustments."
7. Replace blade or trimmer head parts that are cracked, chipped or damaged before using the tool.
8. Use only Weed Eater® .080" diameter Weed Line. Never use wire, rope, string, etc.
9. Use only genuine Weed Eater® replacement parts as recommended.
10. Inspect the entire tool. Replace damaged parts. Check for fuel leaks and make sure all fasteners are in place and securely fastened.

B. STARTER ROPE

▲ DANGER

Never start the engine with the clutch shroud removed. The clutch will fly apart and cause serious injury.

▲ WARNING

Do not remove the retaining tab and screw to remove pulley. The spring beneath the pulley is under tension and can fly out and cause serious injury. If any part of pulley housing assembly is damaged other than the rope, do not use the tool. Take it to your Authorized Service Dealer.

1. Disconnect Spark Plug Wire. Figure 26 .
2. Remove the Top Handle Mounting Screw and Nut, and remove the steel Spacer from the Rubber Bushing on the Handle Mount. Figure 26 .
3. Remove the four clutch shroud screws with the small hex wrench provided. Figure 26 .
4. Separate the Clutch Shroud from the Engine. Figure 26 .

▲ DANGER

Use only a hand tool to remove the clutch. Do not use any type of motorized tool or strike the clutch in any way. Otherwise, the clutch will fly apart and cause serious injury.

5. Hold the "Flats" of the clutch with an adjustable wrench as shown in Figure 27 (inset) and remove the Nut counterclockwise with a 9/16" socket wrench.

NOTE: Clutch will slide off the crankshaft intact. Do not disassemble clutch.

6. Remove the Beveled Washer, Clutch, and Large Flat Washer as shown in Figure 27 .
7. Remove the Pulley Housing from the Engine. Figure 27 .
8. Remove Rope Retaining Screw and remove any remaining rope. (Figure 28).

9. Hold Pulley Housing as shown in Figure 28 . Hand turn the Pulley clockwise as far as it will go. Then, turn the Pulley counterclockwise until the Pulley Notch is aligned with the Housing Notch next to the Retaining Tab and Screw. Figure 28 .
10. Next, turn the Pulley one complete turn counterclockwise until the notches are aligned again.

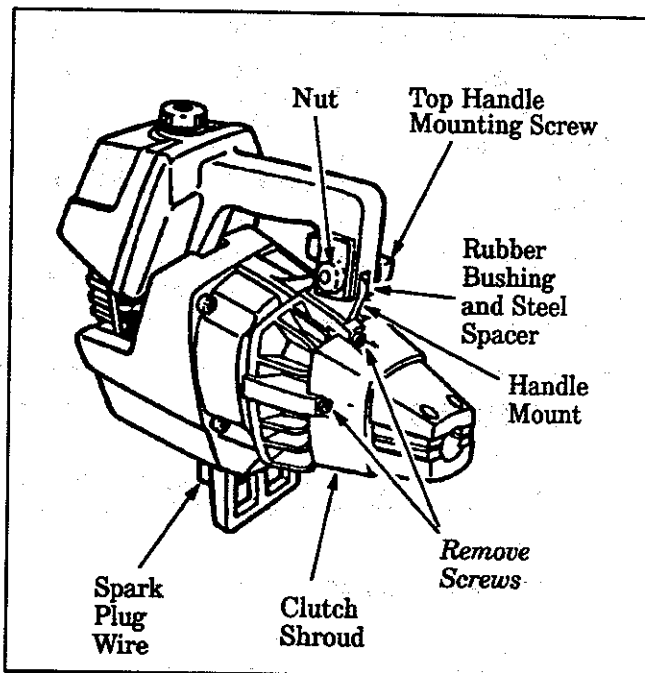

Figure 26

11. Insert the small hex wrench into the hole formed by the Notches to hold the Pulley in position. Figure 28 (inset-upper left).
12. Use a 42" length of replacement Rope.
13. Move 10 feet (3 meters) away from the fuel tank with the replacement rope. Use a match and melt both ends of the Rope to prevent fraying.
14. Pull the melted ends through a thick, clean rag while the Rope is still hot to obtain smooth, pointed ends.

15. Insert one end of the Rope through the Handle and secure with a knot. Leave a 3/16" tail behind the knot. Figure 28 (inset-upper right).
16. Insert the other end of the Rope through the Rope Exit Hole into the inside of the Housing, into the Pulley and up through the Pulley Hole. Figure 28.
17. Wrap the Rope counterclockwise around the Pulley Ratchet and tuck loose end under the Rope at the Pulley Hole. Figure 28. Leave a 1 inch tail laying between the retainer rib and the Rope Retaining Screw/Post. Figure 28.
18. Thread Rope Retainer Screw into the Rope Retaining Post. Tighten screw until the washer is snug against the either the rope or the screw post. Pull firmly on rope to tighten it against the pulley ratchet. Figure 28.

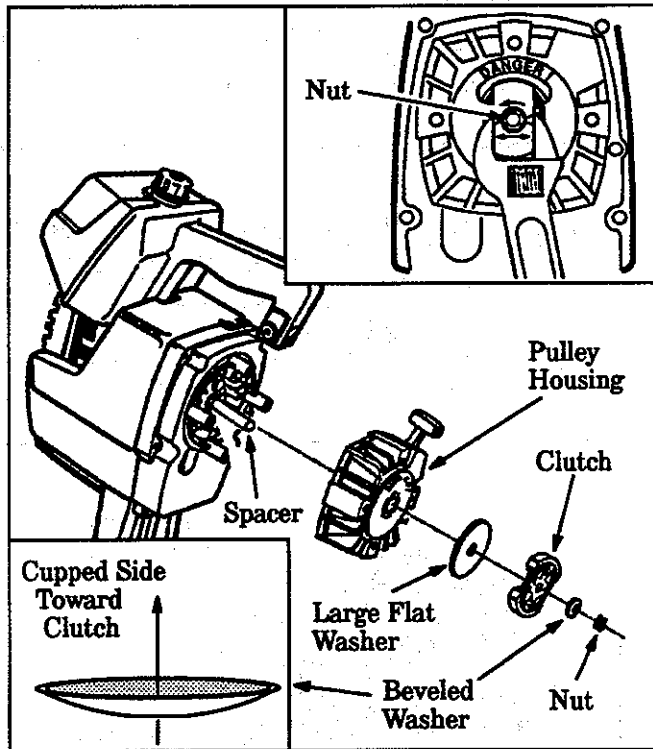

Figure 27

19. Hold the Rope taut at the Rope Exit Hole so the Pulley will not move. Remove hex wrench.
20. Slowly feed rope into the pulley housing.
21. Make sure Spacer is in place as shown in Figure 27, then reverse steps 1 through 7 to re-assemble.

CAUTION: When reinstalling the clutch, install the beveled washer as shown in Figure 27 (inset, lower left) and tighten the nut until the beveled washer is flattened against the clutch. Over or under tightening the nut can cause engine damage.

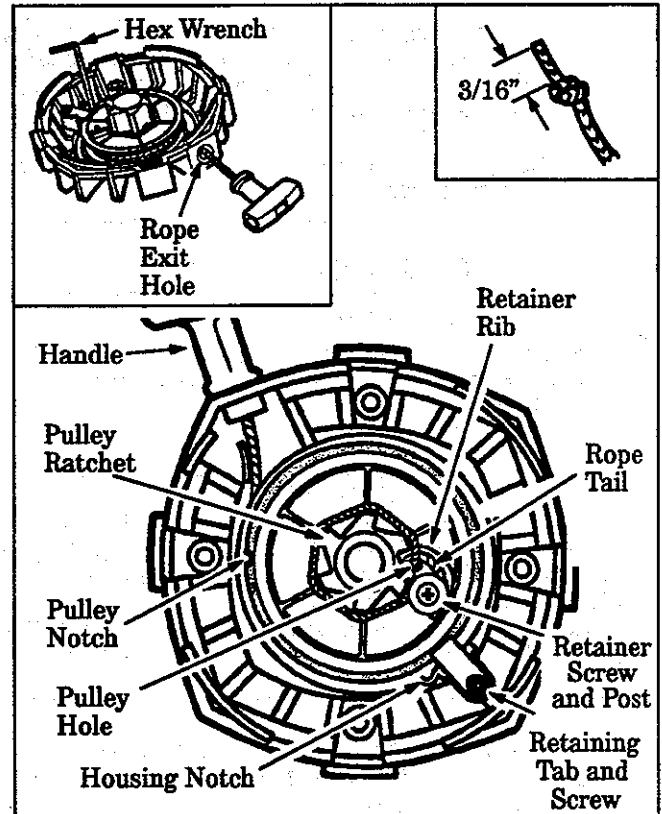

Figure 28

C. AIR FILTER

NOTE: A dirty air filter decreases the life and performance of the engine and increases fuel consumption.

1. Use Air Filter #952-701614.
2. Clean the Air Filter:
 - Always after 5 tanks of fuel or 5 hours of operation, which ever is less.
 - More frequently, in dusty conditions.
 - a. Loosen the two Screws on the Air Filter Cover enough to remove the Cover from the Engine. Figure 29.
 - b. Remove the Air Filter from the Cover. Figure 29.
 - c. Wash Filter in soap and water.
 - d. Squeeze Filter dry and replace in Cover.

CAUTION: Do not clean the air filter in gasoline or other flammable substances to avoid creating a fire hazard.

- e. Reinstall the Air Filter Cover, making sure the choke Exit Slot (Figure 29) is placed over the Choke Lever.

CAUTION: Make sure the air filter is fitted into the corners of the cover to keep dust from entering the engine and causing engine damage.

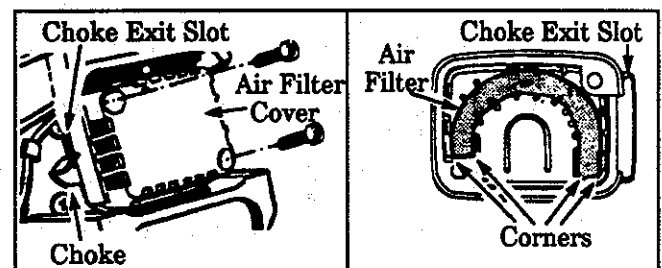

Figure 29

D. CARBURETOR ADJUSTMENTS

NOTE: This is a complicated task. Read all warnings and instructions thoroughly before starting adjustments. If you do not think that you completely understand all warnings and instructions, let your Service Dealer perform these adjustments.

▲ DANGER

Make carburetor adjustments with drive shaft housing supported to prevent blade or trimmer line from contacting any object. Hold the tool with your hand; do not use optional shoulder strap for support.

▲ WARNING

Keep others away when making carburetor adjustments.

▲ WARNING

Serious injury to the operator and others can occur if the carburetor is not properly adjusted.

- Poor engine performance can be a result of other causes such as dirty air filter, carbon build-up on muffler outlets, etc. See "Trouble Shooting Chart" before proceeding with carburetor adjustments.
- The carburetor has been carefully adjusted at the factory. However, the operator must be sure that adjustments are made when any of the conditions occur as mentioned on the next page in "Trouble Shooting Suggestions".
- Very small adjustments can affect engine performance. It is important to turn the screw a very small amount per adjustment and test performance before making further adjustments. Each adjustment should be no more than the width of the slot in the adjusting screw.
- This is a complicated task. Follow instructions in sequence as indicated.

1. TROUBLE SHOOTING SUGGESTIONS

- Engine will not continue to run at idle position. See "Idle Speed Adjustment" and "Low Speed Mixture Adjustment."
- Blade or Trimmer Head continues to spin when the engine idles. See "Idle Speed Adjustment" and "Deceleration Check."
- Engine dies or hesitates when it should accelerate. See "Acceleration Check."
- Loss of cutting power which cannot be corrected by cleaning the air filter. See "High Speed Mixture Adjustment."
- Engine does not return to idle from full throttle within 2 seconds. See "Deceleration Check."
- Engine will not run. See "Trouble Shooting Chart." Then, if the carburetor requires adjustment, begin with "Basic Carburetor Settings."

▲ WARNING

The blade or trimmer line will be spinning during most of this procedure. Wear your protective equipment and observe all safety instructions.

2. BASIC CARBURETOR SETTINGS

NOTE: In most cases, your engine can be made to run properly with minor carburetor adjustments. Refer to "Trouble Shooting Suggestions" in the left column for the condition you are experiencing and follow the instructions. The basic carburetor settings are provided below.

- a. Turn the Low speed Mixture Screw and the High speed Mixture Screw (Figure 30) clockwise until they stop. Do not turn the screws until they are tight as damage to the needle seats can occur.
- b. Turn the Low Speed Mixture and High Speed Mixture Screws between three-quarters and one full turn counterclockwise.
- c. Follow instructions "Preparation," through "High Speed mixture Adjustment."

3. ADJUSTING PROCEDURE

a. PREPARATION

1. Use a fresh fuel mix. See "Fueling Your Engine."
2. Make sure the line extends to the length allowed by the line limiter to provide correct load on engine.
3. Start the engine. Cut grass for 3 minutes to warm engine. The engine must be at operating temperature before carburetor adjustments can be performed correctly.

b. IDLE SPEED ADJUSTMENT

1. Allow engine to idle.
2. Adjust Idle Speed Screw (Figure 30) until the engine continues to run without stalling and without the blade or trimmer head moving.
 - Turn screw clockwise to increase engine speed if the engine stalls or dies.
 - Turn screw counterclockwise to slow engine down and/or to keep blade or trimmer head from turning.
3. Follow instructions in "Acceleration Check" and "Deceleration Check."
4. No further adjustments are necessary if the blade or trimmer head does not turn at idle speed and if performance is satisfactory.

▲ WARNING

Recheck idle speed after each adjustment. The blade or trimmer head must not turn at idle speed to avoid serious injury to the operator and others.

c. ACCELERATION CHECK

1. Allow engine to idle.
2. Squeeze Trigger fully
 - a. If performance is satisfactory, proceed to "d. Deceleration Check."
 - b. If the engine does not accelerate smoothly, turn the Low speed mixture Screw (Figure 30) counterclockwise a small amount (no more than the width of the slot in the adjusting screw).
3. Repeat step "2." until smooth acceleration is obtained.

NOTE: It may be necessary to repeat "Idle Speed Adjustment" through "Acceleration Check," to obtain correct adjustments.

4. Follow instructions in "Deceleration Check."

d. DECELERATION CHECK

1. Allow engine to idle, then squeeze Throttle Trigger fully.
2. Allow engine to run at full speed for about 1 second.
3. Release the Throttle Trigger to the idle position and listen to the deceleration of the engine. It must return to idle smoothly and within 1 to 2 seconds.
 - a. If performance is satisfactory, proceed to step "4."
 - b. If the engine slowly or erratically returns to idle or idles erratically, repeat "Idle Speed Adjustment" or continue through Low Speed Mixture and High Speed Mixture Adjustments to obtain proper deceleration.
4. Recheck idle speed.

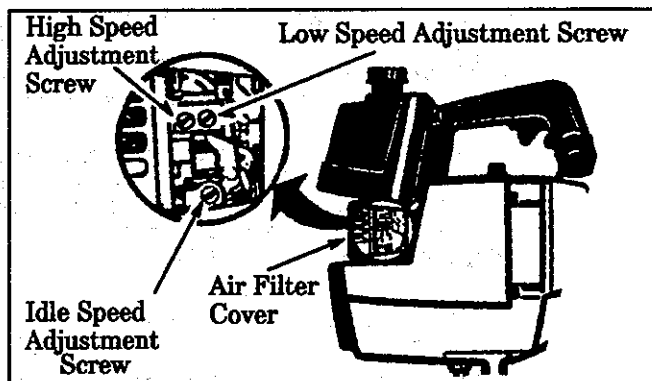

Figure 30

e. LOW SPEED MIXTURE ADJUSTMENT

1. Allow engine to idle.
2. Turn the Low speed Mixture Screw (Figure 30) slowly clockwise until the speed starts to drop. Note this position.
3. Turn the Low speed mixture Screw counterclockwise until the speed increases and then starts to drop again. Note this position.
4. Set the Low speed Mixture Screw at the midpoint between the two positions.
5. Follow instructions in "Acceleration Check" and "Deceleration Check,"

f. HIGH SPEED MIXTURE ADJUSTMENT

CAUTION: Do not operate engine at full throttle for prolonged periods while making high speed adjustments as damage to the engine can occur.

1. Support the drive shaft housing so the blade or trimmer line is off the ground and will not make contact with any object.
2. Allow engine to idle, then squeeze Throttle Trigger fully.

NOTE: Perform steps "3." through "5.," at full throttle.

3. Turn High Speed Mixture Screw (Figure 30) very slowly clockwise until engine speed is reduced.
4. Turn High Speed Mixture Screw very slowly counterclockwise. Stop when the engine begins to run roughly.
5. Turn the screw slowly the minimum amount clockwise until the engine runs smoothly.
6. Follow instructions in "Acceleration Check" and "Deceleration Check".

CAUTION: If the engine does not operate according to these instructions after repeating the adjusting steps, do not use the tool. Take it to your Authorized Service Dealer.

E. FLEXIBLE DRIVE SHAFT LUBRICATION

- Lubricate the Flexible Drive Shaft:
 - After each ten (10) hours of operation.
 - Before operating if the tool has been stored for 90 days or longer.
- Use Flex Shaft Lube #952-701570.

▲ WARNING

If engine has just been operated, avoid touching the muffler. A hot muffler can cause serious burns.

CAUTION: Lay the flexible drive shaft on a clean surface. Avoid laying the shaft on the floor, ground or on any other surface that may have dirt or debris. Even after wiping the shaft, grease residue can pick up dirt particles that can cause damage or premature failure.

CAUTION: Take care to avoid injury to your hands and fingers with broken wires when checking for damage or wiping the flexible drive shaft. A cloth will not prevent broken wires from puncturing or tearing your skin.

1. Remove the Gear Box Clamp Screw and the Locating Screw from the Gear Box. Figure 31.
2. Remove the Gear Box from the Drive Shaft Housing. Figure 31.
3. Remove the Flexible Drive Shaft from the drive Shaft Housing. Figure 32.
4. Check Flexible Drive Shaft for broken wires, twists or kinks, and replace if damage is found.
5. Using a clean cloth, wipe the surface of the Flexible Drive Shaft thoroughly to remove any old grease. Figure 33.
6. Apply a uniform coat of lube to the entire surface of the Flexible Drive Shaft.
7. Inject the remaining contents of the tube into the top of the Drive Shaft Housing.
8. Replace Flexible Drive Shaft in the Drive Shaft Housing. Figure 32.
9. Reassemble the Gear Box to the Drive Shaft Housing. Tighten screws securely.

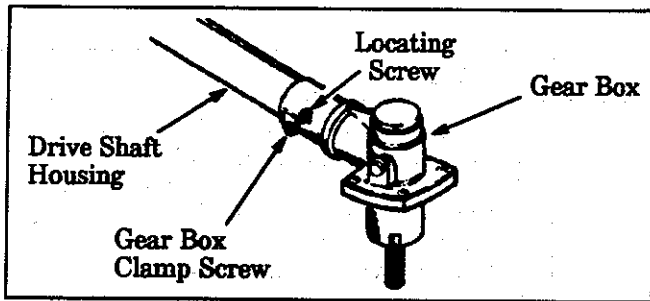

Figure 31

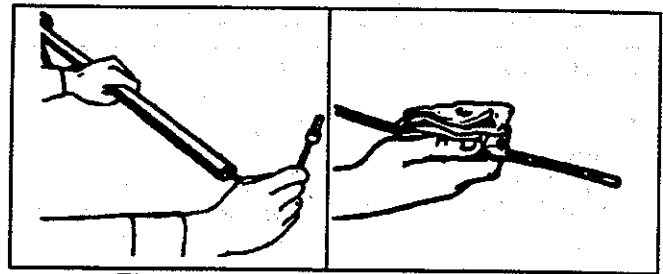

Figure 32

Figure 33

F. BLADE SHARPENING

▲ WARNING

Always stop the engine before sharpening a blade. The blade will continue to spin after the engine stops or after the throttle trigger has been released. Make sure the blade has stopped coasting and disconnect the spark plug before performing work on the blade.

1. The Weed Blade is reversible. When the cutting edge on one side becomes dull, turn the blade over. When both sides of cutting edges become dull, the blade may be resharpened.
2. Check blades for flatness periodically. Lay the blade on a flat surface and inspect the blade for flatness before sharpening. Throw away a blade that is not flat.
3. File or grind each edge in the same manner to maintain a balanced blade as shown. Figure 34.

▲ WARNING

Always replace a blade that is bent, warped, cracked, broken, or damaged in any other way. Never attempt to straighten and re-use a damaged blade. Use only the specified replacement blade.

CAUTION: Wear protective gloves when handling or performing maintenance on the blade to help avoid injury.

▲ WARNING

To prevent the blade from cracking or flying apart after sharpening, do not file within 1/4 inch of the radii shown in Figure 34.

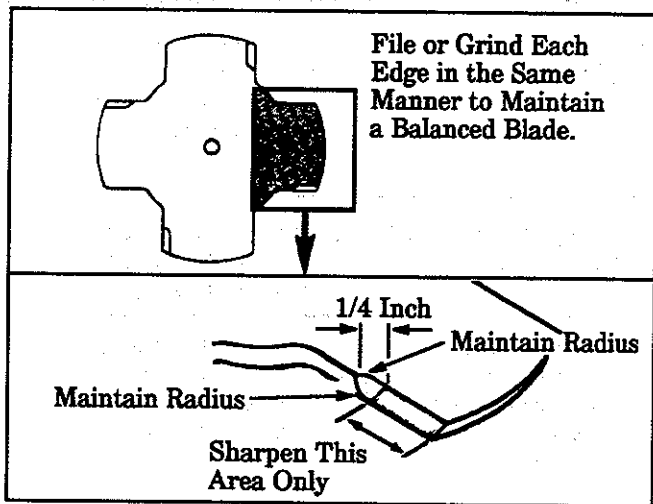

Figure 34

NOTES

G. TROUBLE SHOOTING CHART

SYMPTOM	CAUSE	REMEDY
Engine will not start or will run only for a few seconds after starting.	<ol style="list-style-type: none"> 1. Fuel tank empty. 2. Engine flooded. 3. Spark plug not firing. 4. Fuel not reaching carburetor. 5. Carburetor requires adjustment. 6. None of the above. 	<ol style="list-style-type: none"> 1. Fill tank with correct fuel mixture 2. See "Starting Instructions." 3. Install new plug/check ignition system. 4. Clean fuel filter; inspect fuel line. 5. See "Carburetor Adjustments." 6. Contact your Service Dealer.
Engine will not idle properly.	<ol style="list-style-type: none"> 1. Idle speed set too fast or too slow. 2. Low speed mixture requires adjustment. 3. None of the above. 	<ol style="list-style-type: none"> 1. See "Carburetor Adjustments." 2. See "Carburetor Adjustments." 3. Contact your Authorized Service Dealer.
Engine will not accelerate, lacks power, or dies under a load.	<ol style="list-style-type: none"> 1. Air filter dirty. 2. Spark plug fouled. 3. Carburetor requires adjustment. 4. Muffler outlets plugged. 5. None of the above. 	<ol style="list-style-type: none"> 1. Clean or replace air filter. 2. Clean or replace spark plug and re-gap. 3. See "Carburetor Adjustments." 4. Contact your Authorized Service Dealer. 5. Contact your Authorized Service Dealer.
Engine smokes excessively.	<ol style="list-style-type: none"> 1. Air filter dirty. 2. Fuel mixture incorrect. 3. High speed mixture requires adjustment. 	<ol style="list-style-type: none"> 1. Clean or replace air filter. 2. See "Fueling Your Unit." 3. See "Carburetor Adjustments."
Engine runs hot.	<ol style="list-style-type: none"> 1. Fuel mixture incorrect. 2. High speed mixture set too low (Lean). 3. Spark plug incorrect. 4. None of the above. 	<ol style="list-style-type: none"> 1. See "Fueling Your Unit." 2. See "Carburetor Adjustments." 3. Replace with correct plug. 4. Contact your Authorized Service Dealer.
Cutting attachment turns at idle speed.	<ol style="list-style-type: none"> 1. Carburetor requires adjustment. 2. Throttle Cable binding. 3. Clutch requires repair. 	<ol style="list-style-type: none"> 1. See "Carburetor Adjustments." 2. Contact your Authorized Service Dealer. 3. Contact your Authorized Service Dealer.
Cutting attachment stops under a load or does not turn when engine is accelerated.	<ol style="list-style-type: none"> 1. Drive Shaft not engaged. 2. Drive shaft broken. 3. Carburetor requires adjustments. 4. Clutch requires repair. 	<ol style="list-style-type: none"> 1. See "Assembly," "Drive Shaft Housing." 2. Contact your Authorized Service Dealer. 3. See "Carburetor Adjustments." 4. Contact your Authorized Service Dealer.
Line does not advance or breaks while cutting.	<ol style="list-style-type: none"> 1. Line improperly routed in head. 2. Line improperly wound onto spool. 3. Line size incorrect. 4. Too little line outside head. 5. Dirt accumulated on cover cut-outs. 	<ol style="list-style-type: none"> 1. Remove cover. Check line routing. 2. Rewind line tightly and evenly. 3. Use only .080" dia. WEED LINE Brand Line. 4. Remove cover. Pull 4" of line to outside. 5. Clean cover cut-outs.
Line welds onto spool.	<ol style="list-style-type: none"> 1. Line size incorrect. 2. Incorrect spool. 3. Crowding line against material being cut. 4. Cutting at higher speed than necessary. 	<ol style="list-style-type: none"> 1. Use only .080" dia. WEED LINE Brand Line. 2. Use proper spool. 3. Cut with tip of line. 4. Reduce cutting speed.
Line releases continuously.	<ol style="list-style-type: none"> 1. Line wound beyond notches on spool. 2. Line improperly routed in head. 3. Line size incorrect. 	<ol style="list-style-type: none"> 1. Rewind line tightly and evenly. 2. Remove cover. Check line routing. 3. Use only .080" trimmer line.
Line usage is excessive.	<ol style="list-style-type: none"> 1. Line improperly routed in head. 2. Line size incorrect. 3. Cutting at high speed around hard objects. 4. Crowding line against material being cut. 	<ol style="list-style-type: none"> 1. Remove cover. Check line routing. 2. Use only .080" dia. WEED LINE Brand Line. 3. Reduce speed around hard objects. 4. Cut with tip of line.
Line pulls back into head.	<ol style="list-style-type: none"> 1. Too little line outside of head. 	<ol style="list-style-type: none"> 1. Remove cover. Pull 4" of line to outside.
Excessive vibration.	<ol style="list-style-type: none"> 1. Handle spring(s) out of position. 	<ol style="list-style-type: none"> 1. Reinstall anti-vibration spring onto spring post.

NOTES

1. The first part of the document discusses the importance of maintaining accurate records of all transactions.

2. It is essential to ensure that all entries are supported by proper documentation and receipts.

3. The second section covers the various methods used to collect and analyze financial data.

4. These methods include direct observation, interviews, and the use of specialized software.

5. The third part of the document details the procedures for conducting field research and data collection.

6. It emphasizes the need for thorough planning and organization before beginning the research process.

7. The fourth section discusses the challenges and limitations of different research approaches.

8. Understanding these limitations is crucial for selecting the most appropriate method for a given study.

9. The fifth part of the document provides a comprehensive overview of data analysis techniques.

10. These techniques range from basic statistical analysis to more advanced qualitative methods.

11. The sixth section focuses on the interpretation and reporting of research findings.

12. It highlights the importance of clear communication and the use of appropriate visual aids.

13. The seventh part of the document discusses the ethical considerations that must be taken into account.

14. Researchers must ensure that their work is conducted in a fair and unbiased manner.

15. The eighth section covers the final steps of the research process, including the preparation of a final report.

16. It provides guidance on how to structure the report and present the results effectively.

17. The ninth part of the document discusses the dissemination of research findings to the relevant community.

18. This can be done through various channels, including conferences, journals, and public reports.

19. The tenth and final section of the document provides a summary of the key points discussed.

20. It emphasizes the value of research in understanding complex social and economic issues.

21. The document concludes by encouraging researchers to continue their work and contribute to the field.

PARTS AND SERVICE

Your Poulan/Weed Eater product has been expertly engineered and carefully manufactured to rigid quality standards. As with all mechanical products, some adjustments or part replacement may be necessary during the life of your unit.

FOR SERVICE OR REPLACEMENT PARTS:

1. Consult your dealer/place of purchase.
2. Consult the yellow pages of your phone directory for the name of the nearest Poulan/Weed Eater Master Service Dealer (under "saws" for Chain Saws or under "lawnmowers" for Trimmers, Brushcutters, and Blowers).
3. For replacement parts, have available the following information:
 - a. Description of the tool.
 - b. Model Number.
 - c. Part Number or description of part.

NOTE: Poulan/Weed Eater Division provides parts and service through its authorized distributors and dealers; therefore, all requests for parts and service should be directed to your local dealer(s). The philosophy of Poulan/Weed Eater Division is to continually improve all of its products. If the operating characteristics or the appearance of your product differs from those described in this Operator's Manual, please contact your local Poulan/Weed Eater Dealer for updated information and assistance. Always update your tool when improvements are made available, especially those related to safety. Parts and repair service are not available directly from Poulan/Weed Eater Division White Consolidated Industries, Inc.

POULAN/WEED EATER
DIVISION WHITE CONSOLIDATED INDUSTRIES, INC.
Shreveport, Louisiana 71139-9329

530-067320-5-06/27/91

©1991 Poulan/Weed Eater Division White Consolidated Industries, Inc.