



CUTECH



User Manual

Read this manual before using machine to avoid serious injury and damage

40600H-CT 13" SPIRAL CUTTERHEAD PLANER



For technical support, email support@cutechtools.us or call at **858-886-7333**
VER. 21.05.20

TABLE OF CONTENTS

INTRODUCTION

SECTION 1	Warranty	3
SECTION 2	Product Specifications	4
SECTION 3	Feature Identification	4
SECTION 4	General Safety	5
SECTION 5	Product Safety	8
SECTION 6	Grounding Instructions	10
SECTION 7	Unpacking & Inventory	12
SECTION 8	Assembly	13
SECTION 9	Adjustments	15
SECTION 10	Operations	19
SECTION 11	Maintenance	22
SECTION 12	Troubleshooting	24
SECTION 13	Parts List	25

INTRODUCTION

This user manual is intended for use by anyone working with this machine. It should be kept available for immediate reference so that all operations can be performed with maximum efficiency and safety. Do not attempt to perform maintenance or operate this machine until you have read and understand the information contained in this manual. The drawings, illustrations, photographs, and specifications in this user manual represent your machine at time of print. However, changes may be made to your machine or this manual at any time with no obligation to CUTECH.

WARRANTY

2 YEAR LIMITED WARRANTY

CUTECH warrants its machinery to be free of defects in workmanship and materials for a period of two (2) years from the date of the original purchase by the original owner. This warranty applies to products sold in the United States only. The warranty does not apply to any product used for professional or commercial production purposes nor for industrial or educational applications. Such cases are covered by our 1 year Limited Warranty with the Conditions and Exceptions.

Warranty does not include failures, breakage or defects deemed after inspection by an Authorized Service Center or our agent to have been directly or indirectly caused by or resulting from improper use, lack of or improper maintenance, misuse or abuse, negligence, accidents, damage in handling or transport, or normal wear and tear of any part or component. Examples are consumables such as inserts and knives or wear items like drive belts, bearings or brushes. Additionally, warranty is void if repairs or alterations are made to the machine by an unauthorized service center without the direct consent of CUTECH.

To file a claim of warranty or to find a service center, call 858-886-7333 or email support@cutechtools.us. Warranty applies to the original buyer only and may not be transferred. You will need to furnish with your claim a copy of the original sales receipt as proof of purchase and the serial number from the machine.

The defective units should be returned Freight prepaid to CUTECH's Authorized Service Center for inspection. If the warranty claim is considered to be invalid due to exclusions listed above, CUTECH will at your direction dispose of or return the product. In the event you choose to have the product returned, you will be responsible for the handling and shipping cost of the return.

CUTECH furnishes the above warranties in lieu of all other warranties, express or implied. CUTECH shall not be liable for any special, indirect, incidental, punitive or consequential damages, including without limitation loss of profits arising from or related to the warranty, the breach of any agreement or warranty, or the operation or use of its machinery, including without limitation damages arising from damage to fixtures, tools, equipment, parts or materials, direct or indirect loss caused by any other part, loss of revenue or profits, financing or interest charges, and claims by and third person, whether or not notice of such possible damages has been given to CUTECH. Not responsible for damages of any kind for any delay by or failure of CUTECH to perform its obligations under this agreement or claims made a subject of a legal proceeding against CUTECH more than one (1) year after such cause of action first arose.

The validity, construction and performance of this Warranty and any sale of machinery by CUTECH shall be governed by the law of the State of California, without regard to conflicts of laws provisions of any jurisdiction. Any action related in any way to any alleged or actual offer, acceptance or sale by CUTECH or any claim related to the performance of and agreement including without limitation this Warranty, shall take place in the federal or state courts in San Diego, California.

CUTECH reserves the right to change the specification without prior notice.

PRODUCT SPECIFICATIONS

Feed speed F/min	26 FPM
Cutterhead speed RPM	10,000
Motor RPM	23000+/-10% (No Load)
Cutterhead diameter	2"
Max planer capacity	6" x 13"
Max depth of cut @ 6"	1/8"
Max depth of cut @ 13"	1/16"
Minimum Length of Stock	7"
Minimum Thickness of Stock	1/8"
Cutter inserts qty	26 (2 sided)
Motor power input	115 V, 60 Hz, AC Only, 15 Amp
Shipping Weight	66 lbs.
Shipping Dimensions	26" W x 16" D x 21" H
Dust Port Opening	2 1/2" or 4"

FEATURE IDENTIFICATION

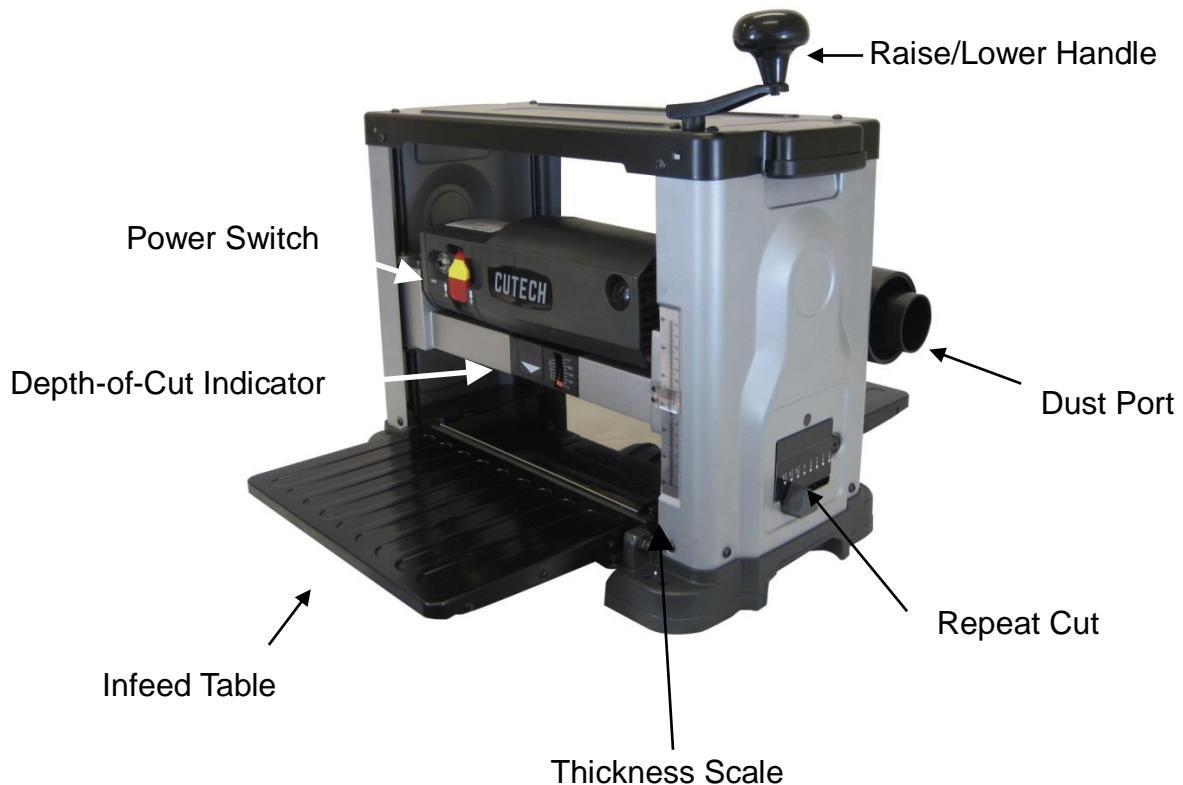

GENERAL SAFETY

NOTE: The **WARNING!** and **CAUTION!** symbols indicate a potentially hazardous situation which, if not avoided, COULD result in death or serious injury. READ THIS MANUAL completely before assembling and operating this machine.

WARNING! TO AVOID serious injury, death, or damage to the machine, please read, understand, and follow, all Safety and Operating Instructions before assembling and operating this machine. This manual is not totally comprehensive. It does not and can not convey every possible safety and operational problem which may arise while using this machine. The manual will cover many of the basic and specific safety procedures needed in an industrial environment.

All federal and state laws, and any regulations having jurisdiction covering the safety requirements for use of this machine, take precedence over the statements in this manual. Users of this machine must adhere to all such regulations.

WARNING! Exposure to the dust created by power sanding, sawing, grinding, drilling and other construction activities may cause serious and permanent respiratory or other injury, including silicosis (a serious lung disease), cancer, and death. Avoid breathing the dust, and avoid prolonged contact with dust. The dust may contain chemicals known to the State of California to cause cancer, birth defects or other reproductive harm.

Some examples of these chemicals are:

- Lead from lead-based paints.
- Crystalline silica from bricks, cement and other masonry products.
- Arsenic and chromium from chemically-treated lumber.

Always operate tool in well ventilated area and provide for proper dust removal. Use a dust collection system along with an air filtration system whenever possible. Always use properly fitting NIOSH/OSHA approved respiratory protection appropriate for the dust exposure, and wash exposed areas with soap and water.

WARNING! ALWAYS wear eye protection. Any machine can throw debris into the eyes during operations, which could cause severe and permanent eye damage. Everyday eyeglasses are NOT safety glasses. ALWAYS wear Safety Goggles (that comply with ANSI standard Z87.1) when operating power tools.

WARNING! ALWAYS wear hearing protection. Plain cotton is not an acceptable protective device. Hearing equipment should comply with ANSI S3.19 Standards.

WARNING! ALWAYS wear a NIOSH/OSHA approved dust mask to prevent inhaling dangerous dust or airborne particles.

GENERAL SAFETY (cont.)

ALWAYS keep the work area clean, well lit, and organized. DO NOT work in an area that has slippery floor surfaces from debris, grease, and wax.

CAUTION! ALWAYS unplug the machine from the electrical receptacle when making adjustments, changing parts or performing any maintenance.

AVOID ACCIDENTAL STARTING. Make sure that the power switch is in the "OFF" position before plugging in the power cord to the electrical receptacle.

WARNING! AVOID a dangerous working environment. DO NOT use electrical tools in a damp environment or expose them to rain or moisture.

WARNING! CHILDPROOF THE WORKSHOP AREA by removing switch keys, unplugging tools from the electrical receptacles, and using padlocks.

CAUTION! DO NOT use electrical tools in the presence of flammable liquids or gasses.

DO NOT FORCE the machine to perform an operation for which it was not designed. It will do a safer and higher quality job by only performing operations for which the machine was intended.

WARNING! DO NOT stand on a machine. Serious injury could result if it tips over or you accidentally contact any moving part.

DO NOT store anything above or near the machine.

WARNING! DO NOT operate any machine or tool if under the influence of drugs, alcohol, or medication.

EACH AND EVERY time, check for damaged parts prior to using any machine. Carefully check all guards to see that they operate properly, are not damaged, and perform their intended functions.

Check for alignment, binding or breakage of all moving parts. Any guard or other part that is damaged should be immediately repaired or replaced.

WARNING! Ground all machines. If any machine is supplied with a 3-prong plug, it must be plugged into a 3-contact electrical receptacle. The third prong is used to ground the tool and provide protection against accidental electric shock. DO NOT remove the third prong.

CAUTION! Keep visitors and children away from any machine. DO NOT permit people to be in the immediate work area, especially when the machine is operating.

GENERAL SAFETY (cont.)

KEEP protective guards in place and in working order.

CAUTION! MAINTAIN your balance. DO NOT extend yourself over the tool. Wear oil resistant rubber soled shoes. Keep floor clear of debris, grease, and wax.

MAINTAIN all machines with care. ALWAYS KEEP machine clean and in good working order. KEEP all blades and tool bits sharp.

NEVER leave a machine running, unattended. Turn the power switch to the OFF position. DO NOT leave the machine until it has come to a complete stop.

REMOVE ALL MAINTENANCE TOOLS from the immediate area prior to turning the machine ON.

WARNING! STAY ALERT, watch what you are doing, and use common sense when operating any machine. DO NOT operate any machine tool while tired or under the influence of drugs, alcohol, or medication. A moment of inattention while operating power tools may result in serious personal injury.

WARNING! USE ONLY recommended accessories. Use of incorrect or improper accessories could cause serious injury to the operator and cause damage to the machine. If in doubt, DO NOT use it.

THE USE of extension cords is not recommended for 230V equipment. It is better to arrange the placement of your equipment and the installed wiring to eliminate the need for an extension cord. If an extension cord is necessary, refer to the chart in the Grounding Instructions section to determine the minimum gauge for the extension cord. The extension cord must also contain a ground wire and plug pin.

CAUTION! Wear proper clothing, DO NOT wear loose clothing, gloves, neckties, or jewelry. These items can get caught in the machine during operations and pull the operator into the moving parts. Users must wear a protective cover on their hair, if the hair is long, to prevent it from contacting any moving parts.

SAVE these instructions and refer to them frequently and use them to instruct other users.

NOTE: Information regarding the safe and proper operation of this tool is also available from the

following sources:

Power Tool Institute
1300 Summer Avenue
Cleveland, OH 44115-2851
www.powertoolinstitute.org

American National Standards Institute
23 West 43rd Street, 4th Floor
New York, NY 10036
www.ansi.org

National Safety Council
1121 Spring Lake Drive
Itasca, IL 60143-3201

ANSI 01.1 Safety Requirements for
Woodworking Machines and the
U.S. Department of Labor Relations
www.osha.gov

PRODUCT SAFETY

1. Serious personal injury may occur if normal safety precautions are overlooked or ignored. Accidents are frequently caused by lack of familiarity or failure to pay attention. Obtain advice from supervisor, instructor, or another qualified individual who is familiar with this machine and its operations.
2. Every work area is different. Always consider safety first, as it applies to your work area. Use this machine with respect and caution. Failure to do so could result in serious personal injury and damage to the machine.
3. Prevent electrical shock. Follow all electrical and safety codes, including the National Electrical Code (NEC) and the Occupational Safety and Health Regulations (OSHA). All electrical connections and wiring should be made by qualified personnel only
4. **WARNING!** TO REDUCE the risk of electrical shock. DO NOT use this machine outdoors. DO NOT expose to rain. Store indoors in a dry area.
5. STOP using this machine, if at any time you experience difficulties in performing any operation. Contact your supervisor, instructor or machine service center immediately.
6. Safety decals are on this machine to warn and direct you to how to protector yourself or visitors from personal injury. These decals MUST be maintained so that they are legible. REPLACE decals that are not legible.
7. DO NOT leave the unit plugged into the electrical outlet. Unplug the unit from the outlet when not in use and before servicing, performing maintenance tasks, or cleaning.
8. **WARNING!** DO NOT handle the plug or planer with wet hands
9. USE only accessories as described in this manual and recommended by CUTTECH.
10. DO NOT pull the planer by the power cord. NEVER allow the power cord to come in contact with sharp edges, hot surfaces, oil or grease.
11. ALWAYS turn the power switch "OFF" before unplugging the planer. DO NOT unplug the planer by pulling on the power cord. ALWAYS grasp the plug, not the cord.
12. REPLACE a damaged cord immediately. DO NOT use a damaged cord or plug.
13. DO NOT use the planer as a toy. DO NOT use near or around children.

PRODUCT SAFETY (cont.)

14. ENSURE that the machine sits firmly before using. If the machine wobbles or is unstable, correct the problem by attaching to a bench top prior to operation.
15. This machine is designed to process wood ONLY.
16. **WARNING!** NEVER position fingers or thumbs near the infeed/ outfeed rollers or cutterhead.
17. Long pieces of stock should ALWAYS be supported with some type of fixture.
18. DO NOT operate planer with dull or damaged blades.
19. MAKE CERTAIN that the planer is properly adjusted prior to use.
20. DO NOT try and remove excessive amounts of wood in one single pass.
21. INSPECT all stock before planing, ensuring that there are no foreign objects embedded in the wood, loose knots, or knots that may become loose during operation.
22. **WARNING!** DO NOT attempt to remove jams until power is disconnected and all moving parts have come to a complete stop.
23. MAKE SURE that there is adequate operating space on both the infeed and outfeed sides of the planer before operating.
24. **WARNING!** DO NOT attempt to plane wood that is less than 7" long or less than 3/16" thick.

GROUNDING INSTRUCTIONS

WARNING! This machine **MUST BE GROUNDED** while in use to protect the operator from electric shock. In the event of a malfunction or breakdown, **GROUNDING** provides the path of least resistance for electric current and reduces the risk of electric shock. The plug **MUST** be plugged into a matching electrical receptacle that is properly installed and grounded in accordance with **ALL** local codes and ordinances.

If a plug is provided with your machine **DO NOT** modify the plug. If it will not fit your electrical receptacle, have a qualified electrician install the proper connections to meet all electrical codes local and state. **ALL** connections must also adhere to **NEC** and **OSHA** mandates.

WARNING! **IMPROPER ELECTRICAL CONNECTION** of the equipment-grounding conductor can result in risk of electric shock. The conductor with the green insulation (with or without yellow stripes) is the equipment-grounding conductor. **DO NOT** connect the equipment-grounding conductor to a live terminal if repair or replacement of the electric cord or plug is necessary.

Check with a qualified electrician or service personnel if you do not completely understand the grounding instructions, or if you are not sure the tool is properly grounded.

WARNING! Electrocutation or fire could result if this machine is not grounded properly or if the electrical configuration does not comply with local and state electrical codes.

MAKE CERTAIN the machine is disconnected from power source before starting any electrical work.

MAKE SURE the circuit breaker does not exceed the rating of the plug and receptacle.

The motor supplied with your machine is a 115 volt, 60 hertz, single phase motor. Never connect the green or ground wire to a live terminal. A machine with a 115 volt plug should only be connected to an outlet having the same configuration as the plug.

WARNING! To reduce the risk of fire or electrical shock, use the proper gauge of extension cord. When using an extension cord, be sure to use one heavy enough to carry the current your machine will draw.

The smaller the gauge-number, the larger the diameter of the extension cord is. If in doubt of the proper size of an extension cord, use a shorter and thicker cord. An undersized cord will cause a drop in line voltage resulting in a loss of power and overheating.

CAUTION! **USE ONLY** a 3-wire extension cord that has a 3-prong grounding plug and a 3-pole receptacle that accepts the machine's plug. If you are using an extension cord outdoors, be sure it is marked with the suffix "W-A" ("W" in Canada) to indicate that it is acceptable for outdoor use.

GROUNDING INSTRUCTIONS (cont.)

Make certain the extension cord is properly sized, and in good electrical condition. Always replace a worn or damaged extension cord immediately or have it repaired by a qualified person before using it.

Protect your extension cords from sharp objects, excessive heat, and damp or wet areas.

MINIMUM RECOMMENDED GAUGE FOR EXTENSION CORDS (AWG)				
115 VOLT OPERATION ONLY				
	25' LONG	50' LONG	100' LONG	150' LONG
0 to 6 Amps	18 AWG	16 AWG	16 AWG	14 AWG
6 to 10 Amps	18 AWG	18 AWG	14 AWG	12 AWG
10 to 12 Amps	16 AWG	16 AWG	14 AWG	12 AWG

UNPACKING & INVENTORY

Check shipping carton and machine for damage before unpacking. Carefully remove packaging materials, parts and machine from shipping carton. Always check for and remove protective shipping materials around motors and moving parts. Lay out all parts on a clean work surface.

Remove any protective materials and coatings from all of the parts and the planer. The protective coatings can be removed by spraying WD-40 on them and wiping it off with a soft cloth. This may need to be redone several times before all of the protective coatings are removed completely.

After cleaning, apply a good quality paste wax to any unpainted surfaces including the infeed, outfeed, and center tables. Make sure to buff out the wax before assembly.

Compare the items to inventory figures and verify that all items are accounted for. If at all possible, retain shipping carton for warranty service if ever needed.

If any parts are missing, do not attempt to plug in the power cord and run the machine. The machine should only be turned "ON" after all the parts have been obtained and installed correctly.

NOTE: Some parts may have been installed at the factory. Please check before calling. For missing parts, contact CUTTECH at **858-886-7333**.



- | | |
|-------------------------|-------|
| 1. DUST PORT | 1 pc |
| 2. HEX WRENCH 4mm x 100 | 1 pc |
| 3. TORX WRENCH | 1 pc |
| 4. RAISE / LOWER HANDLE | 1 pc |
| 5. HEX SCREW M5*P0.8*20 | 1 pc |
| 6. SWITCH SAFETY KEY | 1 pc |
| 7. DUST PORT KNOB | 2 pcs |

ASSEMBLY

WARNING! MAKE CERTAIN THAT THE MACHINE IS DISCONNECTED FROM THE POWER SOURCE.

ATTACHING DEPTH ADJUSTMENT HANDLE

Attach the raise/lower adjustment handle to the shaft located on top of the planer and fasten in place with 1 Hex Socket Head screw. Tighten screw using supplied hex wrench. SEE FIG 1.



FIG 1

ATTACHING DUST PORT

1. Facing the rear of the machine, locate the dust port on the cutterhead assembly by turning 2 dust port knobs. SEE FIG 2.



FIG 2

ASSEMBLY (cont.)

2. To minimize sawdust accumulation on your work piece, attach either a 2-1/2 in. or a 4 in. vacuum hose to the dust port.
3. The dust port must be snapped shut completely or chips may fly out of the front of the planer.
4. The dust port can be opened to allow chips to flow out the back of the planer when a vacuum system is not used. SEE FIG 3.



FIG 3

SECURING PLANER TO A TABLE OR WORKBENCH

During operation, if there is any tendency for the planer to tip over, slide or walk, the planer **MUST** be secured to a supporting surface such as a workbench or table. Four holes are provided (2 are shown at A below) to securely mount the planer. The surface you are mounting the planer to should be perfectly flat. SEE FIG 4.



FIG 4

ADJUSTMENTS

WARNING! MAKE CERTAIN THAT THE MACHINE IS DISCONNECTED FROM THE POWER SOURCE BEFORE ANY ADJUSTMENTS ARE MADE.

LEVELING EXTENSION TABLES

The extension tables must be level with the planer table. To check the extension tables and adjust if necessary:

1. Lay a straight edge (A) on the planer table (C) with one end of the straight edge over the infeed table (B). SEE FIG 5.
2. Check to make sure that the infeed table is level with the planer table.
3. If an adjustment is necessary, raise table, loosen lock nuts (D) and adjust Hex Head Screws (E) on each side of the table until the infeed table is level with the planer table. This will adjust the outer edge of the table.
4. Recheck for level and repeat adjustment if necessary.
5. Repeat this process for leveling the outfeed table.

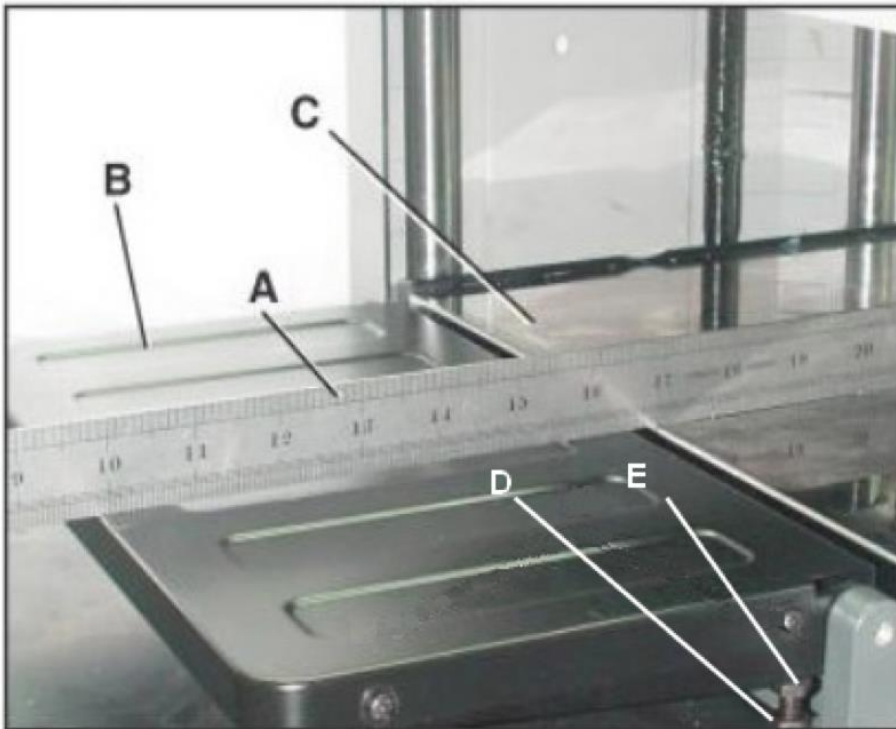

FIG 5

ADJUSTMENTS (cont.)

RAISING AND LOWERING HEAD ASSEMBLY

The head assembly consists of the cutterhead, knives, feed rollers, cutterhead guard, and the motor. Raising and lowering of the head assembly controls the depth of cut on the planer.

To adjust:

1. To raise the head assembly (A), turn the adjusting handle (B) clockwise. SEE FIG 6.
2. To lower the head assembly, turn the adjusting handle counterclockwise.

NOTE: One revolution of the handle will move the cutterhead up or down approximately 1/16". You can confirm this by referencing the scale (C) on the front right side of the planer.

FIG 6

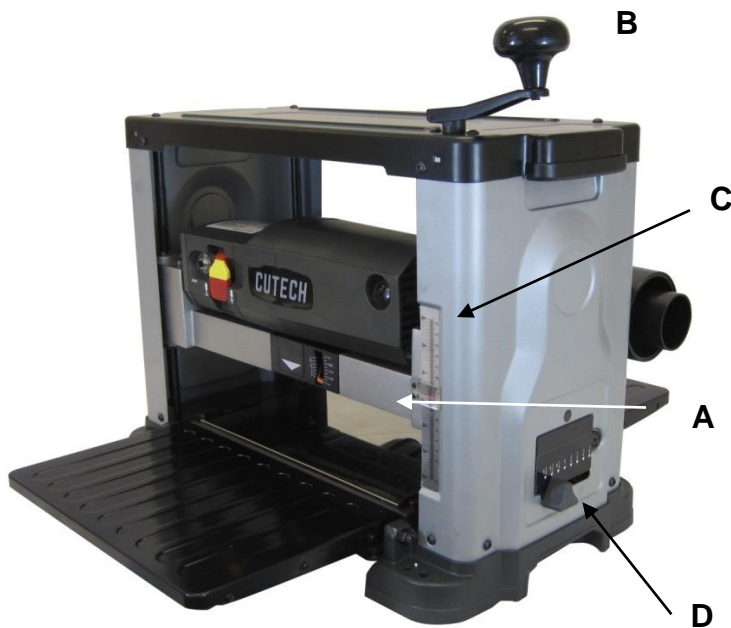

NOTE: The Repeat Cut Thickness Indicator (D), located on the bottom right side of the planer, provides a simple way to preset the finished thickness of a work piece. Slide the indicator to the desired finished thickness. Use this feature when thickness planing multiple work pieces to ensure a uniform thickness of all work pieces. See page 20 for more information. Do not attempt to lower the cutterhead assembly below the preset level as damage will occur.

ADJUSTMENTS (cont.)

ADJUSTING / REPLACING KNIVES FOR 40600H-CT SPIRAL CUTTERHEAD

WARNING! MAKE CERTAIN THAT THE MACHINE IS DISCONNECTED FROM THE POWER SOURCE BEFORE ANY ADJUSTMENTS ARE MADE.

WARNING! *** Be VERY CAREFUL when handling the knives or cutter tips as they are EXTREMELY SHARP and can cause serious injury!!! ***

This 13" cutterhead is equipped with 26 indexable cutter inserts. Each cutter insert can be rotated to reveal one of its two cutting edges. Therefore, if one cutting edge becomes dull or damaged, simply rotate it 90° to reveal a fresh cutting edge.

In addition, each cutter insert has a reference dot on one corner. As the cutter insert is rotated, the reference dot location can be used as an indicator of which edges are used and which are new. When the reference dot revolves back around to its starting position, the cutter should be replaced.

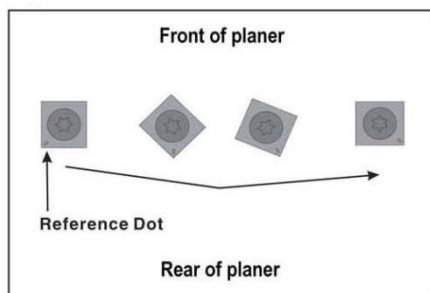

WARNING! NEVER GRASP CUTTERHEAD BY HAND AS THIS WILL RESULT IN SERIOUS INJURY!

To rotate or change cutter tip inserts:

1. Face the rear of the machine. Remove the Dust Port. Refer back to the section labeled ATTACHING DUST PORT in the ASSEMBLY section page 13 for information on removal.
2. Use the handle to lower the cutterhead assembly down to about 2" on the scale.
3. Insert the supplied Hex wrench through the hole located on the side of the machine above the Repeat Cut slider. Rotate the cutterhead to a position where a cutter tip is visible. SEE FIG. 7. next page. (You may have to raise or lower cutterhead to be able to insert the Hex wrench into the cutterhead)
4. While holding the hex wrench to prevent cutterhead rotation, remove the cutter tip screw using the provided Torx T-wrench allowing the tip to be removed.
5. Carefully clean all dust and dirt off the cutter tip and the cutterhead seat. Replace or rotate the cutter insert so a fresh sharp edge is facing outward. If available, use pitch remover to be sure all wood residue is off the cutterhead, cutter insert, and screws, before attempting to rotate or replace them. Using a shot of compressed air is also helpful. Be sure to wear safety glasses when using compressed air.
6. Lubricate the Torx screw threads with light machine oil and wipe the excess oil off the threads. Install cutter tip insert and torque the Torx screw to 48-50 inch/ pounds.

ADJUSTMENTS (cont.)



FIG 7

Note: Proper cleaning of tips and cutterhead is critical to achieving a smooth finish. Dirt or dust trapped between the cutter insert and cutterhead will slightly raise the cutter insert, and make noticeable marks on your work piece the next time you plane.

THICKNESS SCALE ADJUSTMENT

The thickness scale, located on the right of the planer, shows the thickness of the finished work piece. To make sure the scale is set properly, run a piece of wood through the planer and measure the thickness of the wood. If the scale is out of alignment, loosen the two round head screws (A) holding the scale indicator (B) and adjust the thickness indicator to the correct setting. Make sure to re-tighten the two screws once the adjustment is complete. SEE FIG 8.

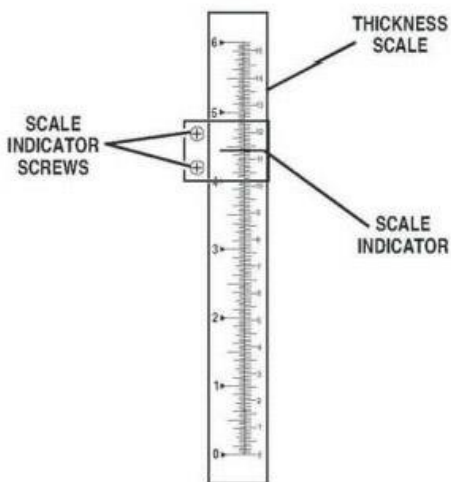

FIG 8

OPERATIONS

NOTE: This operations section was designed to give instructions on the basic operations of this planer. However, it is in no way comprehensive of every planer operation. It is strongly recommended that you read books, trade magazines, or get formal training to maximize the potential of your planer while minimizing the risks.

NOTE: This planer is designed to process wood ONLY.

POWER SWITCH

The planer is turned on by flipping the switch into the up position and it is turned off by flipping the switch in the down position. This planer is also equipped with a special lockout toggle switch that prevents unauthorized use. To prevent unauthorized use of the planer, simply pull out the yellow key (A) located on the face of the switch. SEE FIG 9.



FIG 9

DEPTH-OF-CUT INDICATOR

The Depth-Of-Cut Indicator, located on the front of the machine, is a convenient way to quickly determine how much material is being planed off in one pass.

1. With the machine OFF, insert your work piece just under the cut scale (A). SEE FIG 10.
2. Crank the raising / lowering handle until the button (B) comes in contact with the work piece. As you rotate the raise / lower handle, the needle on the depth of cut scale will move showing how much material will be removed in that pass.

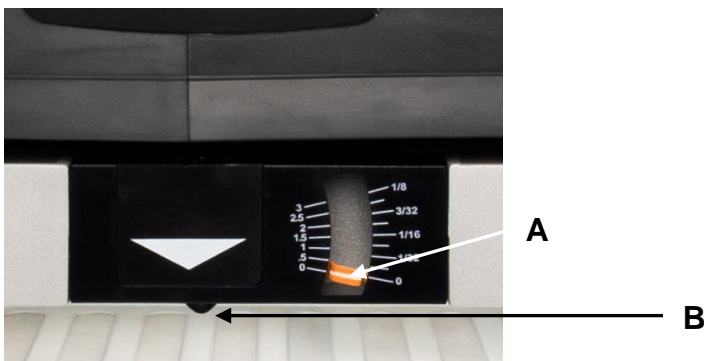

FIG 10

OPERATIONS (cont.)

REPEAT CUT PRESET

The REPEAT CUT preset, located on the right side of the planer, provides a simple way to preset the finished thickness of a work piece. The indicator can be set to various thicknesses. Move the lever to the desired finished thickness. Use this feature when thickness planing multiple work pieces to ensure a uniform thickness of all work pieces. SEE FIG 11.

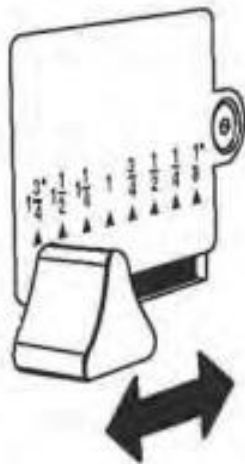

FIG 11

NOTE: When lowering the head assembly, ensure the REPEAT CUT preset is in the lowest desired thickness position. Failure to do so may result in excess downward pressure by the cutterhead assembly onto the mechanism and cause damage to the adjustment rod and upper frame.

OPERATIONS (cont.)

GETTING PREPARED

It is always a good idea to use a piece of scrap wood for your first planing attempt. Also, before each use of the planer, make it a habit of checking for loose fasteners, fittings or hardware. Turn the planer ON and allow it to reach full speed. Pay close attention to any excessively loud noises that may be coming from the planer or any excessive vibration. If either occurs, shut down the planer immediately checking again for loose hardware. Go through the ASSEMBLY and ADJUSTMENTS sections again if necessary.

BASIC OPERATION

WARNING! To avoid serious personal injury, NEVER stand directly in line with the front or rear of the planer. If an object is thrown from the planer, it will travel in this direction.

1. Stand to either the left or right side of the planer.
2. Flip the switch to the ON position.
3. Lift the work piece onto the infeed table by grabbing the edges of the board at the middle of the length. NOTE: For longer pieces, be sure to use additional supports or stands.
4. Push slightly on the board to start feed and allow the feed rollers to pull the board through the planer. Once the feed rollers start to pull the work piece through, let go of the board and allow the rollers to do their job. DO NOT push or pull on the work piece once the rollers have engaged.
5. Move to one side of the rear of the planer and receive the planed work piece by grabbing the edges of the wood like you did when feeding the work piece in.
6. It normally takes several passes of varying depths to achieve a smooth finish, so repeat this process as many times as necessary. Remember the less you take off in a pass, the smoother the finish will be, but you may still need to finish the surface by sanding.

THICKNESS PLANING

Thickness planing sizes the work piece to a desired thickness, while at the same time creating a smooth and level surface. The thickness of each cut will depend on the type of wood, width of the work piece, and condition of the lumber (i.e. dryness, grain composition, straightness, etc). Always make thin test cuts on a scrap piece of wood prior to performing final cuts.

GENERAL TIPS AND GUIDELINES

1. Thickness planing always works best when at least one side of the work piece has a flat surface. If both sides of the work piece are rough, feed one face of the board through the planer until the entire surface is flat.
2. ALWAYS plane both sides of the work piece to reach the desired thickness.
3. DO NOT plane work pieces less than 1/8" thick, less than 3/4-in wide, or shorter than 7-in.
4. It is not recommended to continuously use the planer at its maximum depth of cut (1/16") and at its full width (13") as this will shorten the life of the motor.
5. Light cuts create a smoother finish than heavier cuts.
6. If a smooth cut is not obtained, see TROUBLESHOOTING GUIDE on page 26.

OPERATIONS (cont.)

AVOIDING SNIPE

Snipe, gouging or depression of the board at the ends, can occur when the board is not properly supported. For work pieces longer than 4 ft, greater care must be taken to reduce the problem because the additional length of the work piece translates into more unsupported weight pulling down on the end of the board. This unsupported weight will work against keeping the stock flat. Make sure to use supports or stands whenever long pieces are being planed to avoid this problem. Since snipe occurs at the end of the boards, it is good practice to start with a work piece that is slightly longer than what you need so that you can simply cut off the ends if necessary. Also see TROUBLESHOOTING for further information.

MAINTENANCE

WARNING! MAKE CERTAIN THAT THE MACHINE IS DISCONNECTED FROM THE POWER SOURCE BEFORE PERFORMING ANY MAINTENANCE PROCEDURES

Your planer should provide you with a long time of service provided you take the time to perform the following maintenance operations.

CLEANING

Sawdust buildup and other debris can cause the tool to plane incorrectly. Periodic cleaning and waxing is needed for accurate, precision planing. Any moving parts should be cleaned regularly with a penetrating oil and lubricated with a light coating of medium weight machine oil

CAUTION! With the machine unplugged, blow off motor with low pressure air to remove dust or dirt. Air pressure above 50 P.S.I. should not be used as high-pressured air may damage insulation. The operator should always wear a respirator and eye protection when using compressed air. Do not allow chips and dust to accumulate under the machine. Keep area clean and in safe order.

Having clean feed rollers is essential for optimal results. Check feed rollers after each use for buildup of pitch, gum, or resin, and be sure to clean off with a non-flammable tar and pitch remover that is not harmful to rubberized surfaces.

Periodically clean, wax, and buff the tables. This will aid in the prevention of improper feeding of the work piece.

HARDWARE TIGHTNESS

Periodically check all clamps, nuts, bolts, and screws, for tightness and condition. Stop the machine and recheck the cutterhead screw and knives, or tips, for tightness after about 50 hours of operation. Recheck periodically.

MAINTENANCE (cont.)

BRUSH REPLACEMENT

Brush life will vary depending on the load placed on the motor. The brushes should be inspected every 10-15 hours of use. To inspect or replace:

1. Remove the brush holders, one of which is shown at (A). The other is located in the same position on the rear of the motor assembly. The Brush Holder can be removed using a flat blade screwdriver. SEE FIG 12



FIG 12

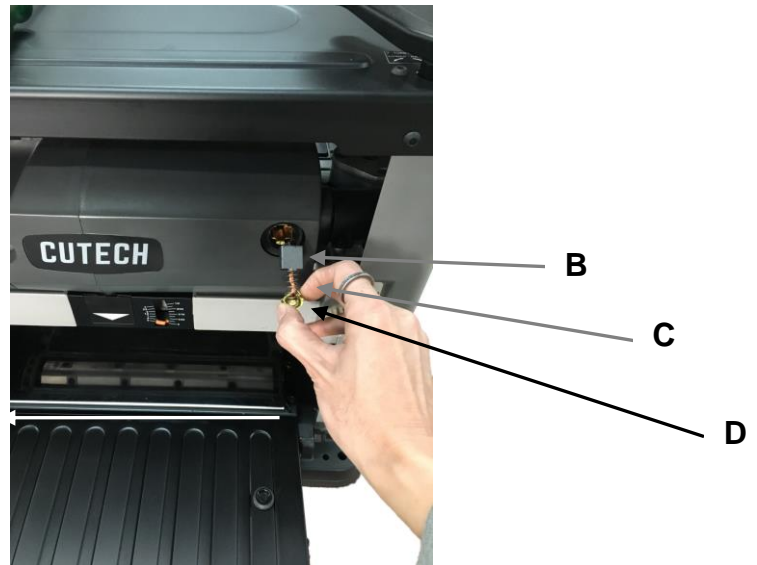

FIG 13

2. Once the brush has been removed, inspect the carbon (B), the spring (C), and the wire (D). SEE FIG 13.
3. If the carbon of either brush is worn down to 3/16" or less, both brushes should be replaced. Also if the spring or wire are burned or damaged in any way, both brushes should be replaced.

TROUBLESHOOTING GUIDE

Motor and Machine Operation

PROBLEM	LIKELY CAUSE	SOLUTION
Snipe (depressions at end of work piece)	Dull Blades Infeed or outfeed tables out of adjustment. Residue on rollers.	Replace or rotate tips. Readjust tables. Feed scrap of same thickness before and after work piece. Clean rollers.
Torn grain.	Too deep or shallow blade setting. Work piece being fed against grain. Dull cutter blades	Reduce or increase the depth of cut. Feed other end of board first. Replace or turn blades. Try skewing board when feeding. VERY slightly dampen work piece.
Fuzzy/rough grain.	High wood moisture content. Dull blades Too deep a blade setting.	Dry wood before planing. Replace or turn blades Reduce depth of cut
Board thickness does not match depth scale indicator.	Depth scale incorrectly set.	Adjust depth scale.
Will not start.	Not plugged in. Blown circuit. Lockout key removed.	Check the power source. Replace fuse, reset breaker, or call electrician. Replace lockout key.
Interrupted operation	Unit overloaded. Circuit overloaded.	Reduce load. Operate on circuit separate from other appliances or motors or connect to circuit with adequate amp rating.
Planer not feeding properly	Too much material being removed. Knives or tips dull. Build up on tables. Build up on rollers.	Reduce cut depth. Replace knives or tips. Clean tables and apply paste wax. Clean rollers with a cleaner safe for rubber surfaces.

PARTS

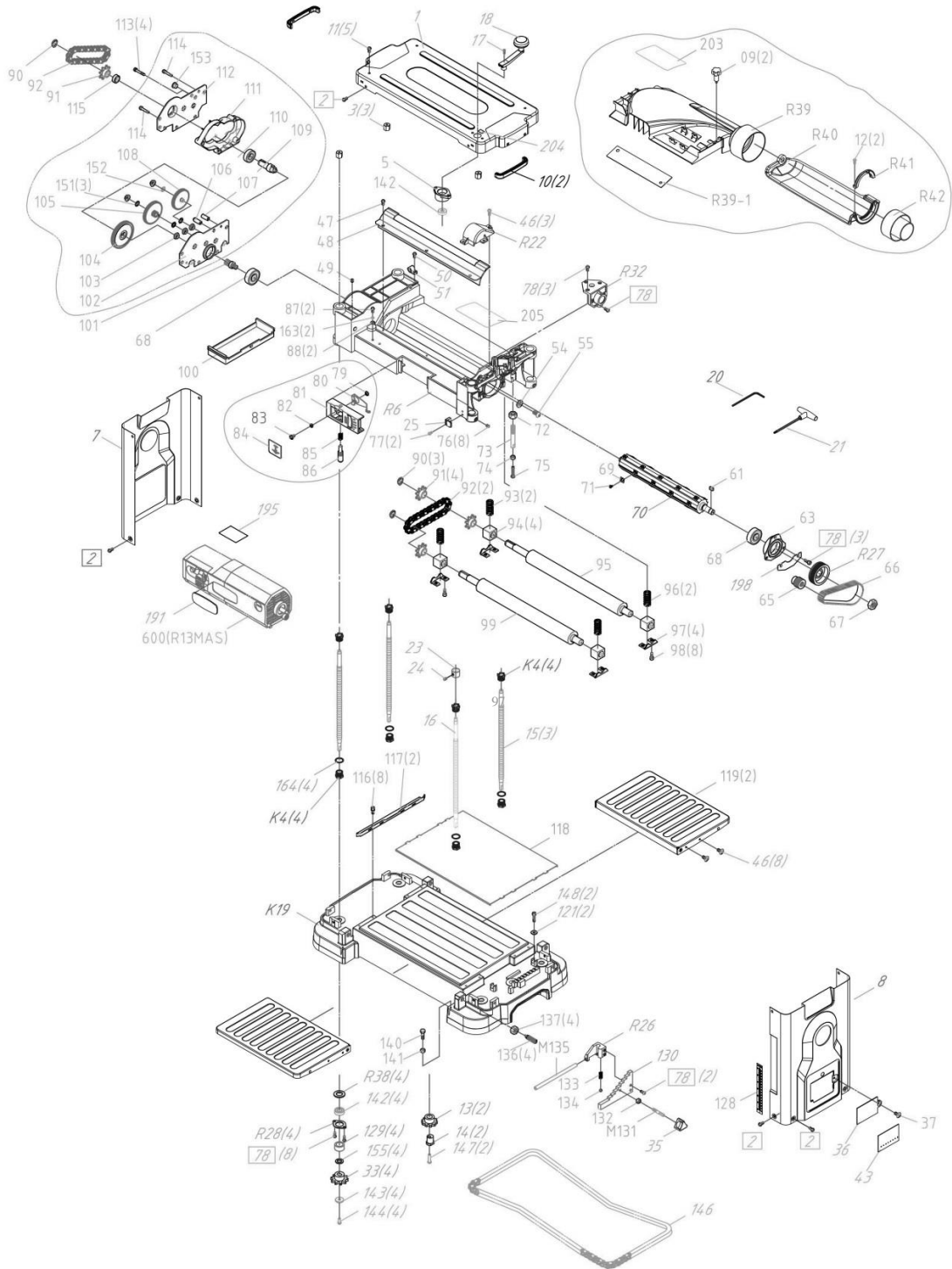

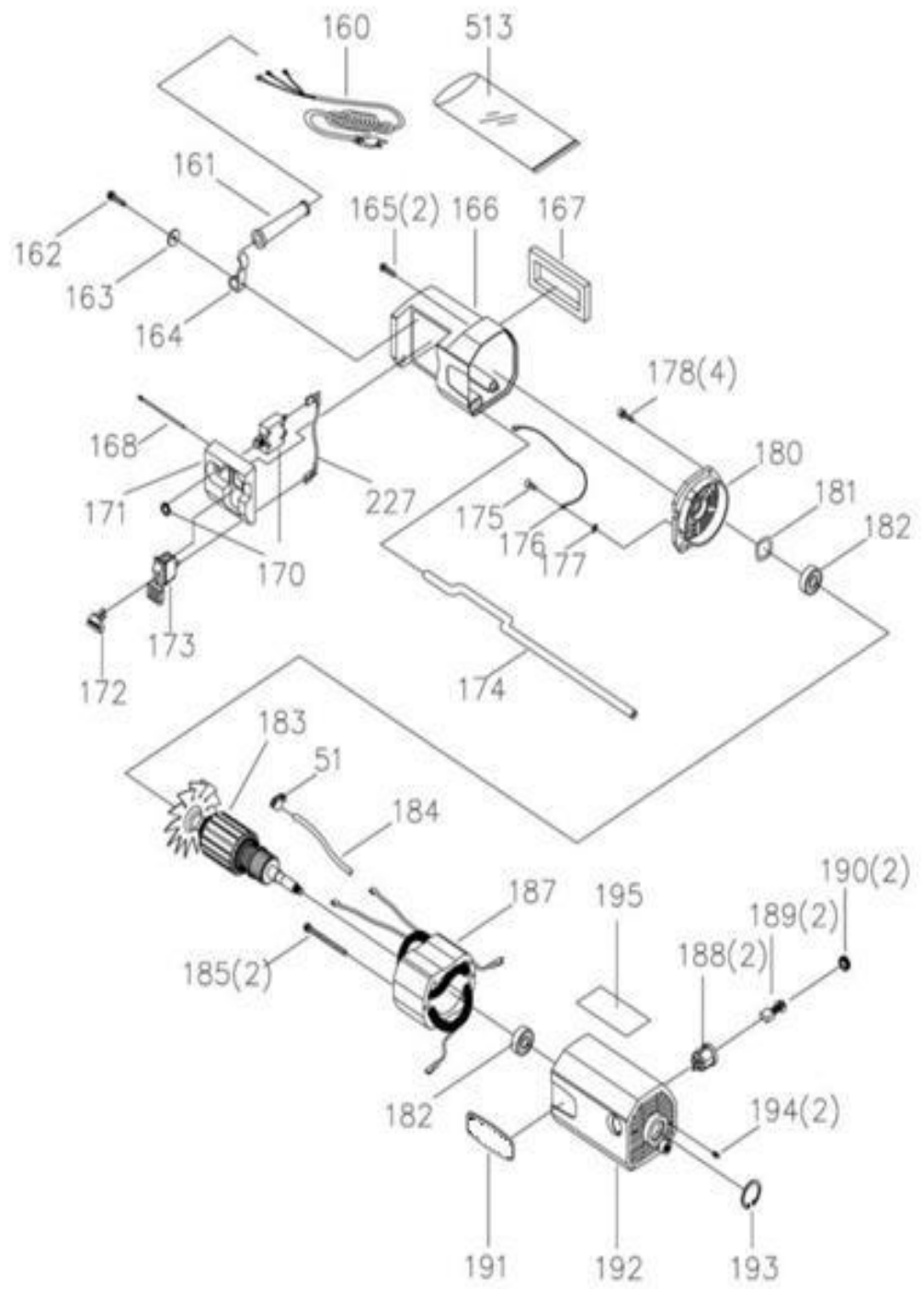

Item no.	Description	Size	Q'ty
1	TOP COVER		1
2	SCR HEX SOC BUT HD	M6xP1.0x8L	12
3	LEAD SCREW BUSHING		3
K4	ELEVATION NUT		8
5	BEARING RETAINER		1
6	UPPER FRAME		1
7	LEFT SIDE PANEL		1
8	RIGHT SIDE PANEL		1
9	KNOB		2
10	HANDLE BAR		2
11	SCR HEX SOC BUT HD	M6xP1.0x10L	5
12	SCR PAN CR TAP	M3xP1.0x16L	2
13	IDLER		2
14	IDLER SHAFT		2
15	SPINDLE		3
16	HEIGHT ADJ SPINDLE		1
17	HEX SOC HD SCR	M5xP0.8x20L	1
18	HAND KNOB ASM		1
18-1	SPINDLE LEVER KNUCKLE		1
18-2	HAND KNOB UPPER		1
18-3	HAND KNOB LOWER		1
18-4	SCREW	M8*P1.25*35L	1
18-5	PLATE	T=1.8 mm	1
18-6	SPRING PIN	3 x 24mm	1
K19	BASE		1
20	HEX WRENCH	4mmX100L	1
21	TORX WRENCH	T25	1
R22	BELT GUARD		1
23	SPACER		1
24	NYLOCK SCR SOC SET CUP PT		1
25	POINTER	H=17.5	1

Item no.	Description	Size	Q'ty
R26	BLOCK GUARD		1
R27	CUTTERHEAD PULLEY		1
R28	PLATE		4
R32	HANDWHEEL BRACKET		1
33	CHAIN WHEEL		4
35	KNOB		1
36	RIGHT SIDE PANEL COVER		1
37	SCREW	M6XP1.0X12L	1
R38	SPECIAL WASHER	12.5x § 25.8x2t	4
R39*	DUST HOOD		1
46	PHILLIPS SCREW	M4XP0.7X10L	11
47	SCREW	M5XP0.8X8L	3
48	CHIP DEFLECTOR		1
49	SCREW	M5XP0.8X8L	1
50	SCREW	M5XP0.8X10L	1
51	CORD CLAMP	GCL-5/16 S	1
54	WASHER	8.5x § 18x2t	1
55	HEX SOCKET BUTTON SCREW	M8xP1.25x20L	1
61	KEY	5X12L	1
63	RETAINER BEARING		1
65	MOTOR PULLEY		1
66	V-BELT	135J6	1
67	HEX NUT	M16XP2.0L.H	1
68	BALL BEARING	6203ZZ	2
69	CUTTER INSERT		26
70	HELICAL CUTTERHEAD		1
71	TORX SCREW	M5xP0.8x9.6L	26
72	HEX NUT	M10 X14XP1.5	1
M73	THICKNESS ADJUST ROD		1
74	HEX NUT	M5XP0.8	1
75	ADJUST SCREW	M5XP0.8X25L	1

Item no.	Description	Size	Q'ty
76	SCREW	M5XP0.8X6L	8
77	PHILLIPS BUTTON SCREW	M3XP0.5X22L	2
78	HEX SOCKET BUTTON SCREW	M5xP0.8x12L	18
79*	DEPTH OF CUT	M4	1
87	SCR PAN CR TYTT	M5X8L	2
88	LOCKWASHER EXT	M5	2
89	GEAR BOX		*1
90	C-RING	STW15	3
91	CHAIN WHEEL		4
92	CHAIN		2
93	SPRING		2
94	BLOCK BEARING		4
95	OUTFEED ROLLER		1
96	SPRING		2
97	PLATE RETAINER		4
98	SCR HEX SOC CAP	M5XP0.8X10L	8
99	INFEED ROLLER		1
100*	GEAR BOX		1
101	GEAR (12T)	12T	1
115	SPACER	15x § 20x7	1
116	SCR SEMS W/WASH	M5XP0.8X10L	8
117	RAIL GUIDE		2
118	PLATE WEAR		1
119	EXTENSION TABLE		2
121	WASHER	5.3x § 12x1.5t	2
128	SCALE		1
129	SPACER	10.5x § 18x12t	4
130	STEP BLOCK		1
M131	STEP BLOCK PIN		1
132	HEX NUT	M6XP1.0	1
133	SPRING	7.62X § 15.75X § 0.7	1

Item no.	Description	Size	Q'ty
134	STEEL BALL	10MM	1
M135	PIVOT ROD		1
136	ADJUST SCREW	M10xP1.5	4
137	HEX NUT	M10xP1.5	4
140	HEX SCREW	M6XP1.0X25L	4
141	HEX NUT	M6XP1.0	4
142	BALL BEARING	6000zz	5
143	WASHER	4.2x § 15x2t	4
144	SCR HEX SOC CAP	M4XP0.7X12L	4
146	CHAIN		1
147	HEX SOC BUTTON SCREW	M5XP0.8X25L	2
148	SCR HEX SOC CAP	M5XP0.8X16L	2
153	PLUG		1
155	WASHER		4
163	SPRING WASHER		2
164	WASHER	19.8x § 23.5x0.8t	4
191	LOGO LABEL		1
195	SPEC LABEL		1
198	SIDE PLATE		1
600*	MOTOR/SWITCH ASM		*1