

D-CUT[®]

OPERATION MANUAL

D-CUT Flooring Cutter LX-080

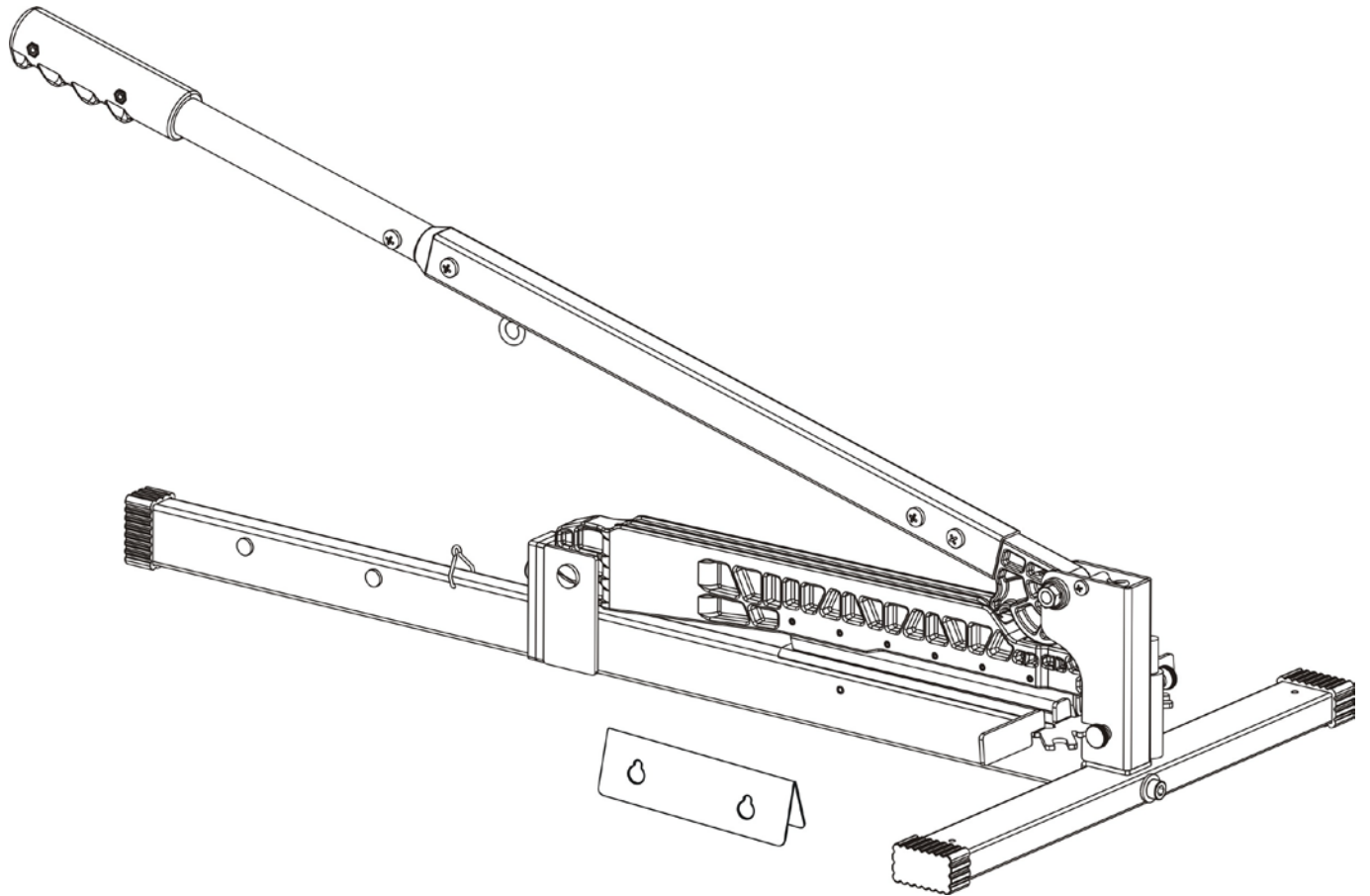



WARNING: FAILURE TO FOLLOW THESE RULES MAY RESULT IN SERIOUS INJURY! USING THIS MACHINE WITH RESPECT AND CAUTION WILL CONSIDERABLY LESSEN THE POSSIBILITY OF PERSONAL INJURY.

SAFETY RULES FOR THE FLOORING CUTTER

- 1. READ AND UNDERSTAND THIS INSTRUCTION MANUAL BEFORE OPERATING THE D-CUT MULTI-FLOORING CUTTERS.**
2. If you are not thoroughly familiar with the operation of D-Cut Multi-flooring Cutter, obtain advice from a qualified instructor or call 800-982-3434 USA
3. Stay alert. Do not operate while under the influence of drugs, alcohol, or medication.
4. Always wear safety approved eye protection with side shields(ANSI Z87.1)
5. Keep work area free of debris.
6. Keep children and unauthorized persons away from the D-Cut Multi-flooring Cutter and work area.
7. Make sure tool is secure. Operate only on a firm substrate or solid stand.
8. Use the right tool. Do not force the D-Cut Multi-flooring Cutter or use it for a job for which it was not designed; use only on approved materials.
9. Keep the tungsten steel blade sharp. A cracked blade will not perform properly. Note: Our blade does not need re-sharpening.
10. Always keep hands away from blade while operating or carrying the cutter.
11. Do not alter or misuse this tool. The D-Cut Multi-flooring Cutter is precision built; modifications not specified in this manual may result in a dangerous and unsafe environment.
12. Maintain the D-Cut Multi-flooring Cutter with care. Keep Blade sharp and clean. Follow instructions for changing accessories.
13. Use only recommended accessories. The use of improper accessories may be hazardous and cause injuries.
14. Never leave the D-Cut Multi-flooring Cutter unattended. Secure the handle with the lock chain when not in use.



SET UP

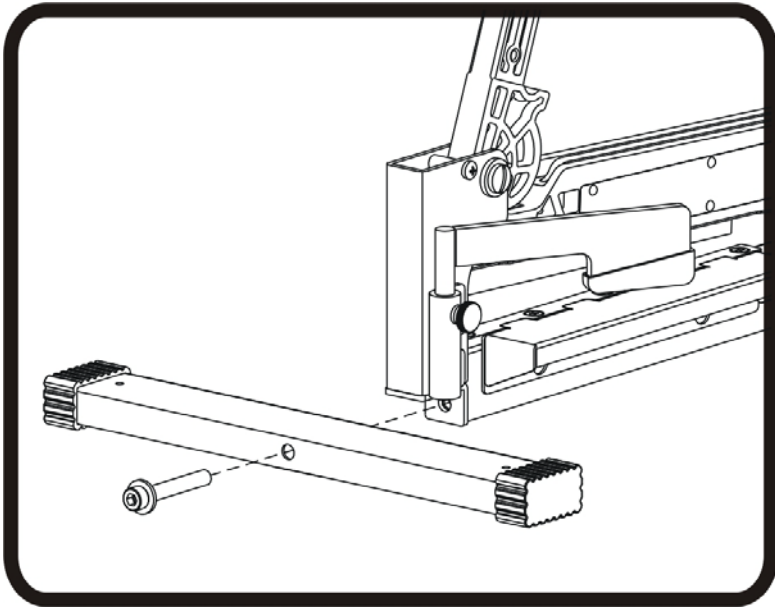

Installation of the Cutter (1)

Install the cross bar to the cutter base with the provided bolt as shown.

Warning: Do not put your fingers against the sharp edge of the blade at any time.

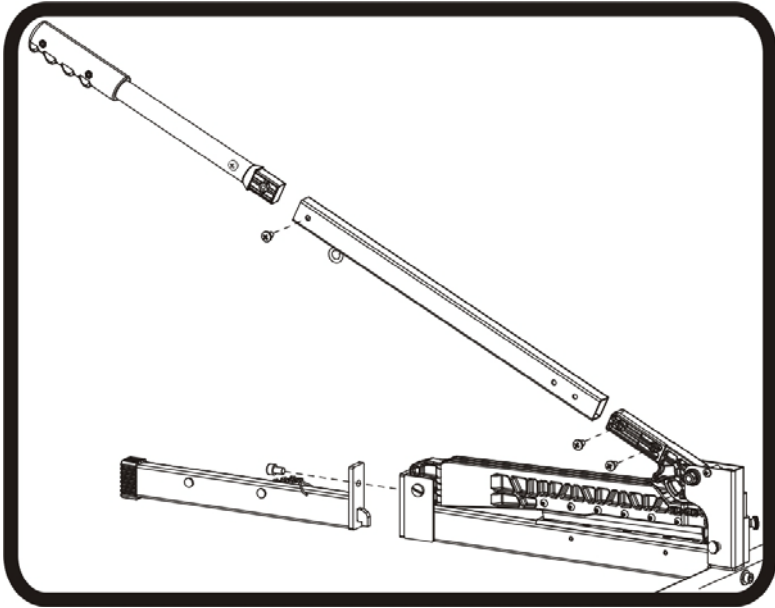

Installation of the Cutter (2)

Insert the handle to the base and install the rear base to the front base with the provided screws as shown.

Warning: Do not put your fingers against the sharp edge of the blade at any time.

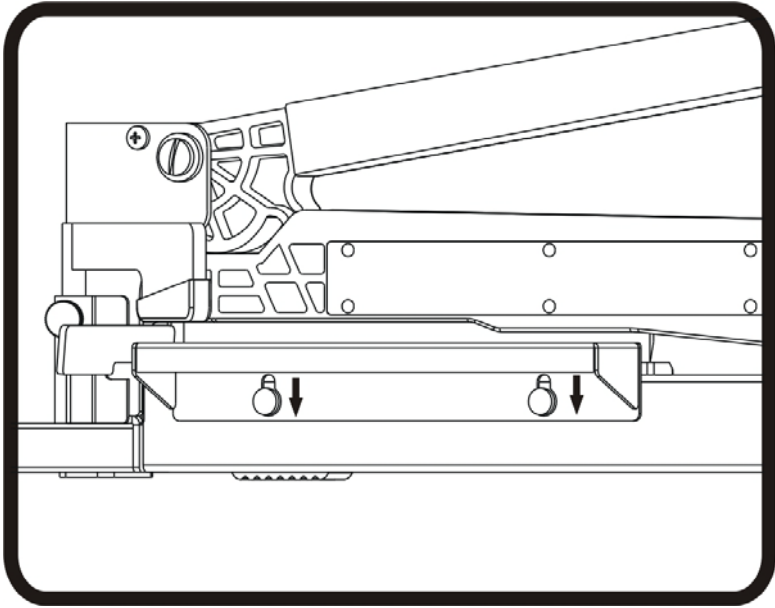

Working Table

Install the working table as shown.

Warning: Do not put your fingers against the sharp edge of the blade at any time.

CUTTING



Cutting Preparation

Place the angle attachment into the cutter head and push it as much as you can to the bottom. Change the cutting angle 0° or 45° as needed. After the attachment is set up, lock it as shown.

Warning: Do not put your fingers against the sharp edge of the blade at any time.

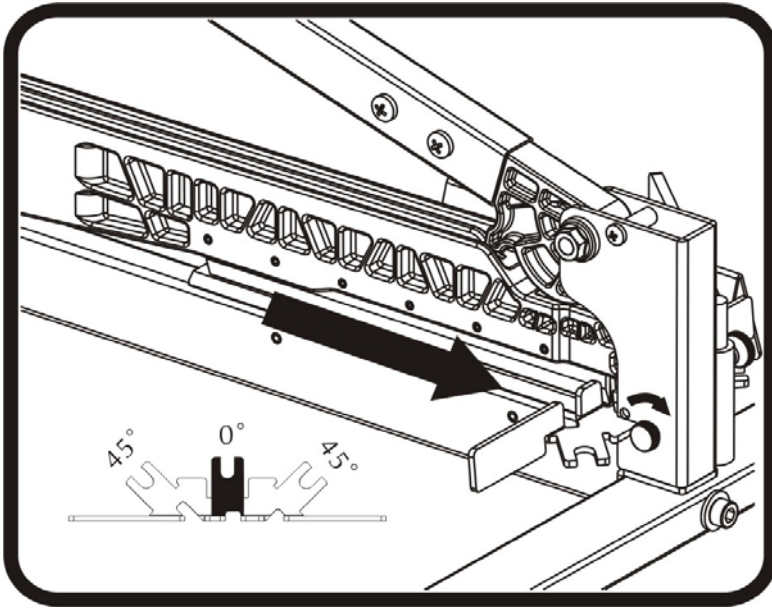

Cutting (1)

Insert material between the cutting blade and the base as shown and hold the material with the flooring holding bar, then push handle down to complete a cut.

Warning: Maintain control of the handle. Do not allow handle to slam back after making a cut.

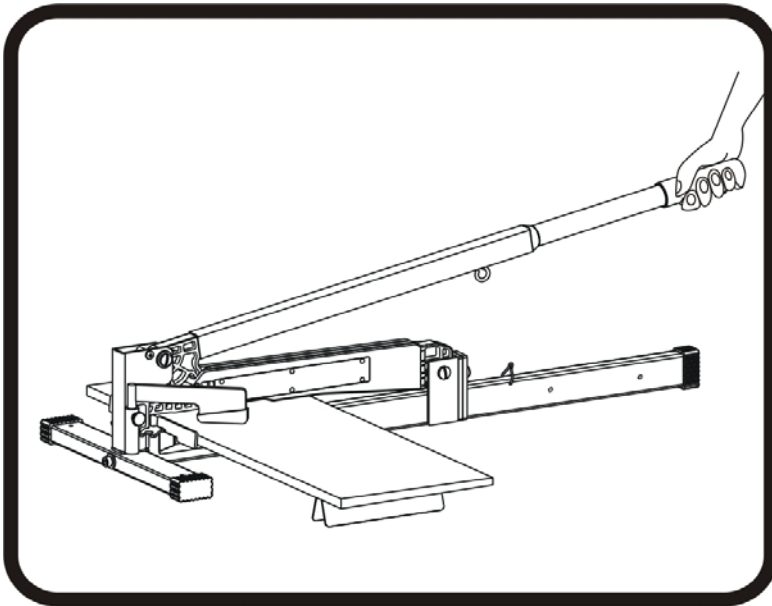

Cutting (2)

Install the $0-45^\circ$ Attachment as shown. Insert material and hold the material with the flooring holding bar, then push handle down to complete a cut.

Warning: Maintain control of the handle. Do not allow handle to slam back after making a cut.

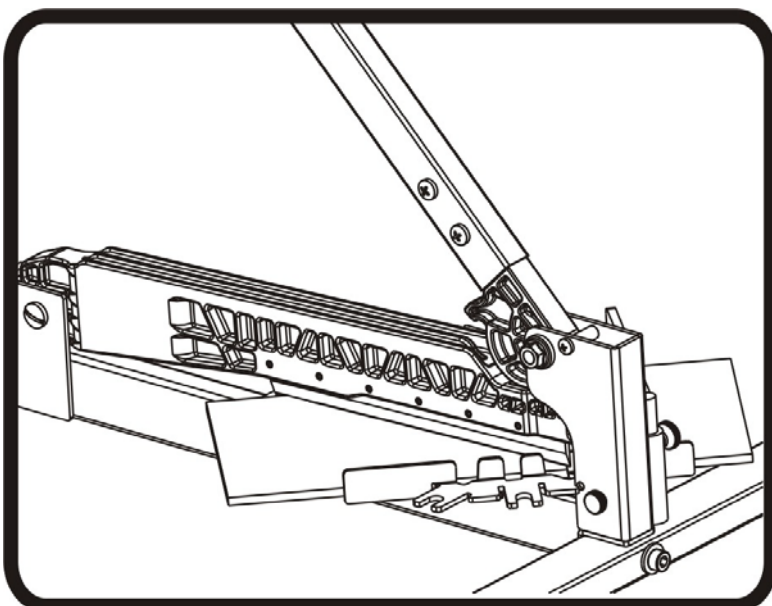



MAINTENANCE

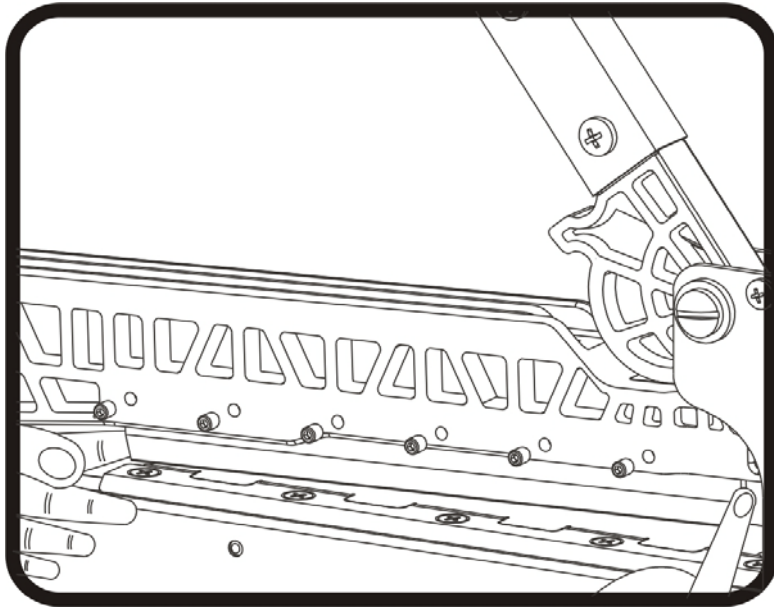

Changing the Blade

Use the provided Allen wrench to remove the six screws, then hold the blade by each end and carefully remove the blade out of the blade holder.

Note: The flat side of the blade faces the table.

Warning: Do not put your fingers against the sharp edge of the blade at any time.

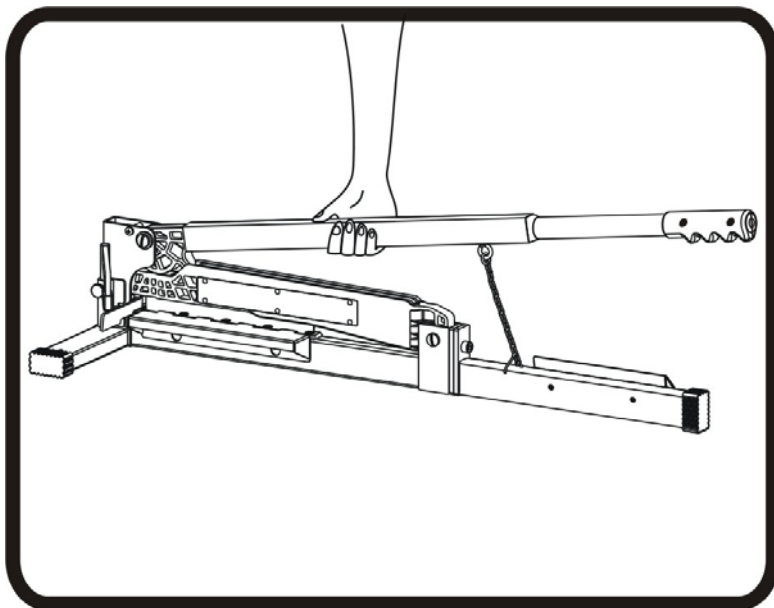

Transport

Hook the chain to the ring on the handle and carry the cutter as shown.

Warning: Do not put your fingers against the sharp edge of the blade at any time.

PARTS LIST

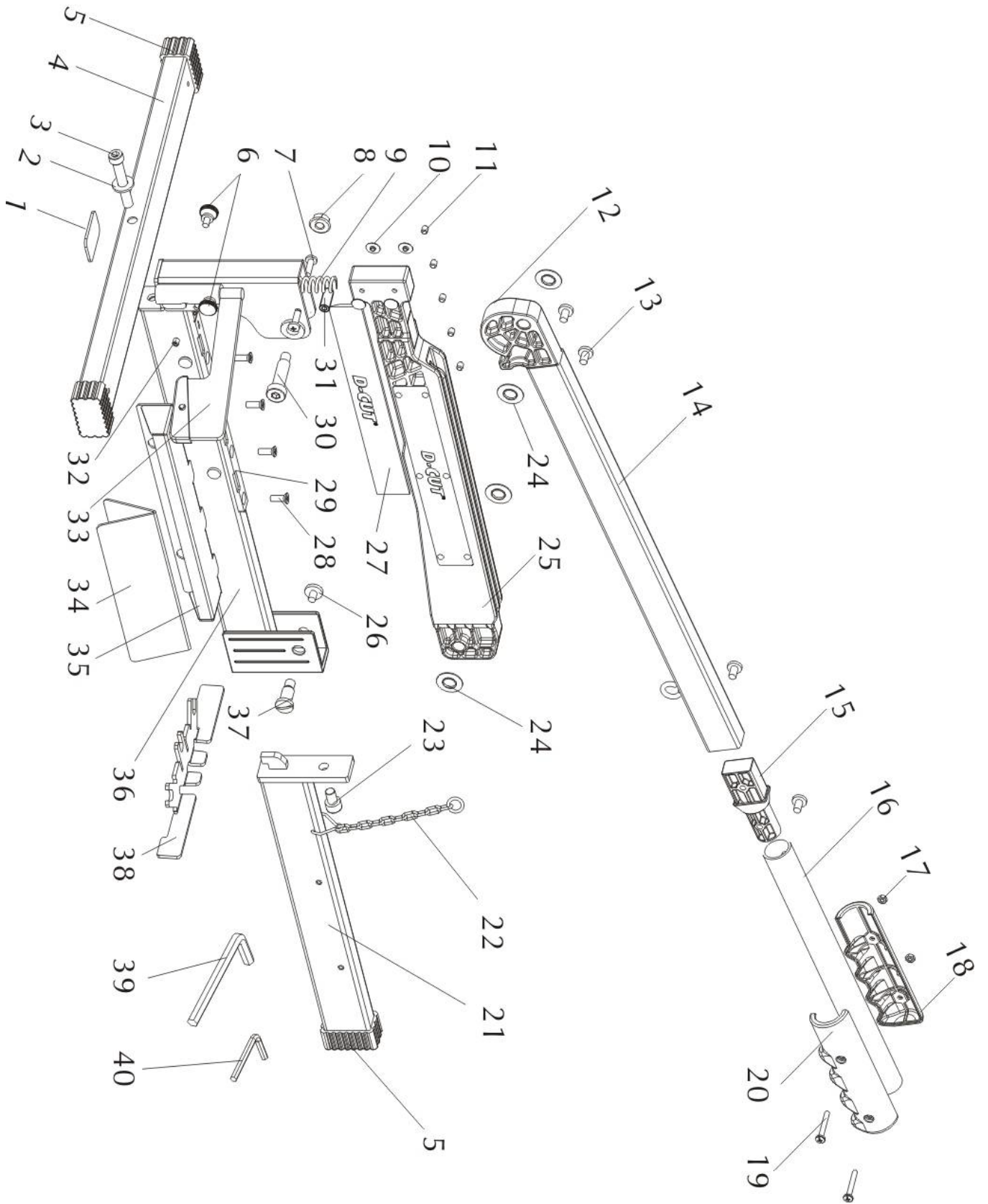



PARTS LIST

	Parts	Q'ty		Parts	Q'ty
1	Rubber Pad	1	21	Rear Base	1
2	Plain Washer $\Phi 8$	1	22	Chain	1
3	Hex Head Screw M8 \times 52	1	23	Hex Head Screw M8 \times 12	1
4	Cross Bar	1	24	Nylon Washer-2	2
5	End Cap	3	25	Blade Holder	1
6	Knurled Screw M5	2	26	Customized Screw M6	1
7	Cross Head Screw M5 \times 10	2	27	Blade	1
8	Nylon Lock Nut M8	1	28	Cross Head Screw M5 \times 10	5
9	Spring	1	29	Nylon Bar	1
10	Nylon Washer-1	4	30	Customized Screw M10	1
11	Hex Head Screw M5 \times 10	5	31	Round Tube Stopper	1
12	Eccentric Handle	1	32	Hex Head Screw M5 \times 6	1
13	Cross Head Screw M6 \times 10	4	33	Flooring Holding Bar	1
14	Square Tube Handle	1	34	Supporting Stand	1
15	Handle Connector	1	35	Working Table	1
16	Round Handle	1	36	Cutter Base	1
17	Thin Nut M4	2	37	Customized Solenoid M6	1
18	Right ABS Handle	1	38	Angle Attachment	1
19	Cross Head Screw M4 \times 31	2	39	Allan Wrench M8	1
20	Left ABS Handle	1	40	Allan Wrench M5	1

D-Cut LX Series Cutting Capacity Chart



! WARNING
VERY SHARP BLADE

WOOD FLOORING	Janka Rate	LX-230		LX-080
		Limit on Solid Wood Flooring	Limit on Engineered Wood Flooring	Limit on Engineered Wood Flooring
Eastern White Pine	380	Yes	Yes	Yes
Basswood	410	Yes	Yes	Yes
White Pine	420	Yes	Yes	Yes
Hemlock	500	Yes	Yes	Yes
Chestnut	540	Yes	Yes	Yes
Larch	590	Yes	Yes	Yes
Douglas Fir	660	Yes	Yes	Yes
Southern Yellow Pine (Loblolly and Shortleaf)	690	Yes	Yes	Yes
Shedua	710	Yes	Yes	Yes
Sycamore	770	Yes	Yes	Yes
Parana	780	Yes	Yes	Yes
Lacewood / Leopardwood	840	Yes	Yes	Yes
Southern Yellow Pine (Longleaf)	870	Yes	Yes	Yes
Cedar	900	Yes	Yes	Yes
Paper Birch	910	Yes	Yes	Yes
Boire	940	Yes	Yes	Yes
Black Cherry / Imbuia	950	Yes	Yes	Yes
Sakura	995	Yes	Yes	Yes
Teak	1000	Yes	Yes	Yes
Black Walnut	1010	Yes	Yes	Yes
Boreal	1023	Yes	Yes	Yes
Makore	1100	Yes	Yes	Yes
Brazilian Eucalyptus / Rose Gum	1125	Yes	Yes	Yes
Cocobolo	1136	Yes	Yes	Yes
Carbonized Bamboo (represents one species)	1180	Yes	Yes	Yes
Heart Pine	1225	Yes	Yes	Yes
Movingui	1230	Yes	Yes	Yes
Yellow Birch	1260	Yes	Yes	No
Carribean Heart Pine	1280	Yes	Yes	No
Red Oak (Northern)	1290	Yes	Yes	No
American Beech	1300	Yes	Yes	No
Ash (White)	1320	Yes	Yes	No
Ribbon Gum	1349	Yes	Yes	No
Tasmanian Oak	1350	Yes	Yes	No
White Oak	1360	Yes	Yes	No
Australian Cypress	1375	Yes	Yes	No
Natural Bamboo (represents one species)	1380	Yes	Yes	No
Coffee Bean	1390	Yes	Yes	No
Hard Maple / Sugar Maple	1450	No	Yes	No
Sweet Birch	1470	No	Yes	No

Curupixa	1490	No	Yes	No
Sapele / Sapelli	1510	No	Yes	No
Kambala	1540	No	Yes	No
Peroba	1557	No	Yes	No
True Pine / Timborana	1570	No	Yes	No
Zebrawood	1575	No	Yes	No
Tualang	1624	No	No	No
Wenge / Red Pine	1630	No	No	No
Highland Beech	1686	No	No	No
Locust	1700	No	No	No
Kempas	1710	No	No	No
Merbau	1712	No	No	No
Blackwood	1720	No	No	No
African Padauk	1725	No	No	No
Rosewood	1780	No	No	No
Bangkirai	1798	No	No	No
Afzelia / Doussie	1810	No	No	No
Hickory / Pecan / Satinwood	1820	No	No	No
Goncalo Alves / Tigerwood	1850	No	No	No
Purpleheart	1860	No	No	No
Jarrah	1910	No	No	No
Amendoim	1912	No	No	No
Merbau	1925	No	No	No
Tallowwood	1933	No	No	No
Cameron	1940	No	No	No
Bubinga	1980	No	No	No
Sydney Blue Gum	2023	No	No	No
Karri	2030	No	No	No
Brushbox	2135	No	No	No
Pradoo	2170	No	No	No
Santos Mahogany / Bocote / Cabreuva	2200	No	No	No
Mesquite	2345	No	No	No
Brazilian Cherry / Jatoba	2350	No	No	No
Spotted Gum	2473	No	No	No
Red Mahogany / Turpentine	2697	No	No	No
Bloodwood	2900	No	No	No
Angelim Pedra	3040	No	No	No
Brazilian Redwood / Paraju	3190	No	No	No
Ebony	3220	No	No	No
Cumaru / Brazilian Teak	3540	No	No	No
Ipe / Brazilian Walnut / Lapacho	3684	No	No	No

Strictly follow this Cutting Capability Chart. Any attempt to cut flooring harder than what is listed may cause personal injury as well as damage to the product.