



**REGISTER YOUR TOOLS**  
<http://register.ryobitools.com>  
 1-800-525-2579

# OPERATOR'S MANUAL

## MANUEL D'UTILISATION

## MANUAL DEL OPERADOR

### 10 in. TABLE SAW

### SCIE À TABLE DE 254 mm (10 po)

### SIERRA DE MESA DE 254 mm (10 pulg.)

#### RTS23

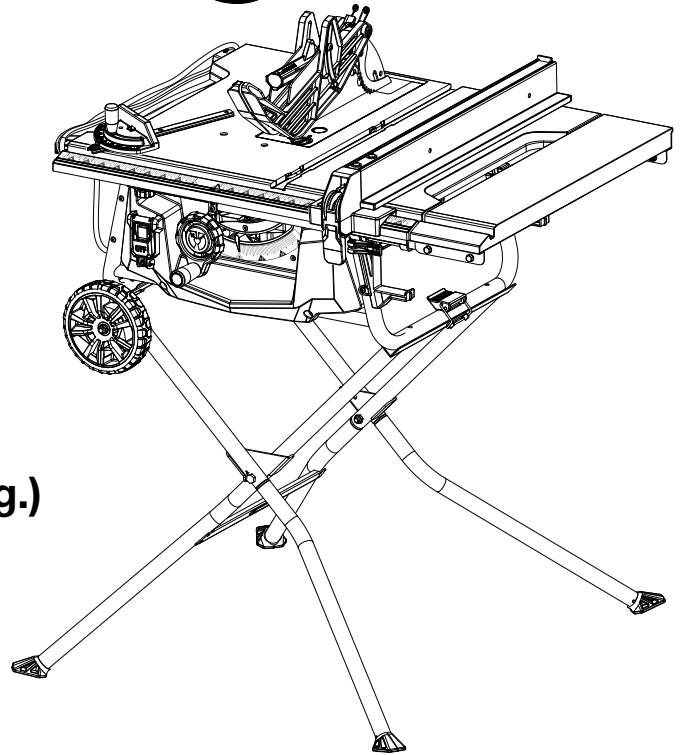

#### TABLE OF CONTENTS

\*\*\*\*\*

- General Safety Rules.....2-3
- Table Saw Safety Rules.....3-5
- Additional Safety Rules .....5
- Symbols.....6
- Electrical.....7
- Glossary of Terms.....8
- Features.....9-11
- Tools Needed .....12
- Loose Parts List.....13
- Assembly.....14-24
- Operation.....25-43
- Adjustments .....44-46
- Maintenance.....47-48
- Accessories .....48
- Troubleshooting.....49-50
- Parts Ordering / Service..... Back Page

#### TABLE DES MATIÈRES

\*\*\*\*\*

- Règles de sécurité générales .....2-3
- Règles de sécurité scie à table .....3-5
- Règles de sécurité supplémentaires.....5
- Symboles.....6
- Caractéristiques électriques.....7
- Glossaire.....8
- Caractéristiques .....9-11
- Outils nécessaires .....12
- Liste des pièces détachées.....13
- Assemblage.....14-24
- Utilisation.....25-43
- Réglages.....44-46
- Entretien .....47-48
- Accessoires .....48
- Dépannage.....49-50
- Commande de pièces / réparation.....Page arrière

#### ÍNDICE DE CONTENIDO

\*\*\*\*\*

- Reglas de seguridad generales.....2-3
- Reglas de seguridad sierra de mesa .....3-5
- Advertencias de seguridad adicionales .....5
- Símbolos .....6
- Aspectos eléctricos.....7
- Glosario de términos .....8
- Características .....9-11
- Herramientas necesarias.....12
- Lista de piezas sueltas .....13
- Armado.....14-24
- Funcionamiento.....25-43
- Ajustes.....44-46
- Mantenimiento.....47-48
- Accesorios.....48
- Corrección de problemas.....49-50
- Pedidos de piezas / servicio..... Pág. posterior

**⚠ WARNING:** To reduce the risk of injury, the user must read and understand the operator's manual before using this product.

**⚠ AVERTISSEMENT :** Pour réduire les risques de blessures, l'utilisateur doit lire et veiller à bien comprendre le manuel d'utilisation avant d'employer ce produit.

**⚠ ADVERTENCIA:** Para reducir el riesgo de lesiones, el usuario debe leer y comprender el manual del operador antes de usar este producto.

**SAVE THIS MANUAL FOR FUTURE REFERENCE**

**CONSERVER CE MANUEL POUR FUTURE RÉFÉRENCE**

**GUARDE ESTE MANUAL PARA FUTURAS CONSULTAS**

# GENERAL SAFETY RULES

## **WARNING:**

**Read all safety warnings, instructions, illustrations and specifications provided with this power tool.** Failure to follow all instructions listed below may result in electric shock, fire and/or serious injury.

### **Save all warnings and instructions for future reference.**

The term “power tool” in the warnings refers to your mains-operated (corded) power tool or battery-operated (cordless) power tool.

## **WORK AREA SAFETY**

- **Keep work area clean and well lit.** Cluttered or dark areas invite accidents.
- **Do not operate power tools in explosive atmospheres, such as in the presence of flammable liquids, gases or dust.** Power tools create sparks which may ignite the dust or fumes.
- **Keep children and bystanders away while operating a power tool.** Distractions can cause you to lose control.

## **ELECTRICAL SAFETY**

- **Power tool plugs must match the outlet. Never modify the plug in any way. Do not use any adapter plugs with earthed (grounded) power tools.** Unmodified plugs and matching outlets will reduce risk of electric shock.
- **Avoid body contact with earthed or grounded surfaces, such as pipes, radiators, ranges and refrigerators.** There is an increased risk of electric shock if your body is earthed or grounded.
- **Do not expose power tools to rain or wet conditions.** Water entering a power tool will increase the risk of electric shock.
- **Do not abuse the cord. Never use the cord for carrying, pulling or unplugging the power tool. Keep cord away from heat, oil, sharp edges or moving parts.** Damaged or entangled cords increase the risk of electric shock.
- **When operating a power tool outdoors, use an extension cord suitable for outdoor use.** Use of a cord suitable for outdoor use reduces the risk of electric shock.
- **If operating a power tool in a damp location is unavoidable, use a ground fault circuit interrupter (GFCI) protected supply.** Use of a GFCI reduces the risk of electric shock.

## **PERSONAL SAFETY**

- **Stay alert, watch what you are doing and use common sense when operating a power tool. Do not use a power tool while you are tired or under the influence of drugs, alcohol or medication.** A moment of inattention while operating power tools may result in serious personal injury.

- **Use personal protective equipment. Always wear eye protection.** Protective equipment such as dust mask, non-skid safety shoes, hard hat, or hearing protection used for appropriate conditions will reduce personal injuries.
- **Prevent unintentional starting. Ensure the switch is in the off-position before connecting to power source and/or battery pack, picking up or carrying the tool.** Carrying power tools with your finger on the switch or energizing power tools that have the switch on invites accidents.
- **Remove any adjusting key or wrench before turning the power tool on.** A wrench or a key left attached to a rotating part of the power tool may result in personal injury.
- **Do not overreach. Keep proper footing and balance at all times.** This enables better control of the power tool in unexpected situations.
- **Dress properly. Do not wear loose clothing or jewelry. Keep your hair, clothing and gloves away from moving parts.** Loose clothes, jewelry or long hair can be caught in moving parts.
- **If devices are provided for the connection of dust extraction and collection facilities, ensure these are connected and properly used.** Use of dust collection can reduce dust-related hazards.
- **Do not let familiarity gained from frequent use of tools allow you to become complacent and ignore tool safety principles.** A careless action can cause severe injury within a fraction of a second.

## **POWER TOOL USE AND CARE**

- **Do not force the power tool. Use the correct power tool for your application.** The correct power tool will do the job better and safer at the rate for which it was designed.
- **Do not use the power tool if the switch does not turn it on and off.** Any power tool that cannot be controlled with the switch is dangerous and must be repaired.
- **Disconnect the plug from the power source and/or remove the battery pack, if detachable, from the power tool before making any adjustments, changing accessories, or storing power tools.** Such preventive safety measures reduce the risk of starting the power tool accidentally.
- **Store idle power tools out of the reach of children and do not allow persons unfamiliar with the power tool or these instructions to operate the power tool.** Power tools are dangerous in the hands of untrained users.
- **Maintain power tools and accessories. Check for misalignment or binding of moving parts, breakage of parts and any other condition that may affect the power tool's operation. If damaged, have the power tool repaired before use.** Many accidents are caused by poorly maintained power tools.

# GENERAL SAFETY RULES

- **Keep cutting tools sharp and clean.** Properly maintained cutting tools with sharp cutting edges are less likely to bind and are easier to control.
- **Use the power tool, accessories and tool bits etc. in accordance with these instructions, taking into account the working conditions and the work to be performed.** Use of the power tool for operations different from those intended could result in a hazardous situation.
- **Keep handles and grasping surfaces dry, clean and free from oil and grease.** Slippery handles and grasping surfaces do not allow for safe handling and control of the tool in unexpected situations.

## SERVICE

- **Have your power tool serviced by a qualified repair person using only identical replacement parts.** This will ensure that the safety of the power tool is maintained.

# TABLE SAW SAFETY RULES

## BLADE GUARD, RIVING KNIFE AND ANTI-KICKBACK PAWLS

- **Keep guards in place. Guards must be in working order and be properly mounted.** A guard that is loose, damaged, or is not functioning correctly must be repaired or replaced.
- **Always use saw blade guard, riving knife and anti-kickback pawls for every through-cutting operation.** For through-cutting operations where the saw blade cuts completely through the thickness of the workpiece, the guard and other safety devices help reduce the risk of injury.
- **Immediately reattach the guarding system after completing an operation (such as rabbeting, dadoing or resawing cuts) which requires removal of the guard, riving knife and/or anti-kickback pawls.** The guard, riving knife, and anti-kickback pawls help to reduce the risk of injury.
- **Make sure the saw blade is not contacting the guard, riving knife or the workpiece before the switch is turned on.** Inadvertent contact of these items with the saw blade could cause a hazardous condition.
- **Adjust the riving knife as described in the instruction manual.** Incorrect spacing, positioning and alignment can make the riving knife ineffective in reducing the likelihood of kickback.
- **For the riving knife and anti-kickback pawls to work, they must be engaged in the workpiece.** The riving knife and anti-kickback pawls are ineffective when cutting workpieces that are too short to be engaged with the riving knife and anti-kickback pawls. Under these conditions a kickback cannot be prevented by the riving knife and anti-kickback pawls.
- **Use the appropriate saw blade for the riving knife.** For the riving knife to function properly, the saw blade diameter must match the appropriate riving knife and the body of the saw blade must be thinner than the thickness of the riving knife and the cutting width of the saw blade must be wider than the thickness of the riving knife.

## CUTTING PROCEDURES

- **DANGER: Never place your fingers or hands in the vicinity or in line with the saw blade.** A moment of inattention or a slip could direct your hand towards the saw blade and result in serious personal injury.
- **Feed the workpiece into the saw blade against the direction of rotation.** Feeding the workpiece in the same direction that the saw blade is rotating above the table may result in the workpiece, and your hand, being pulled into the saw blade.
- **Never use the miter gauge to feed the workpiece when ripping and do not use the rip fence as a length stop when cross cutting with the miter gauge.** Guiding the workpiece with the rip fence and the miter gauge at the same time increases the likelihood of saw blade binding and kickback.
- **When ripping, always apply the workpiece feeding force between the fence and the saw blade. Use a push stick when the distance between the fence and the saw blade is less than 150 mm, and use a push block when this distance is less than 50 mm.** “Work helping” devices will keep your hand at a safe distance from the saw blade.
- **Use only the push stick provided by the manufacturer or constructed in accordance with the instructions.** This push stick provides sufficient distance of the hand from the saw blade.
- **Never use a damaged or cut push stick.** A damaged push stick may break causing your hand to slip into the saw blade.
- **Do not perform any operation “freehand”. Always use either the rip fence or the miter gauge to position and guide the workpiece.** “Freehand” means using your hands to support or guide the workpiece, in lieu of a rip fence or miter gauge. Freehand sawing leads to misalignment, binding and kickback.
- **Never reach around or over a rotating saw blade.** Reaching for a workpiece may lead to accidental contact with the moving saw blade.

# TABLE SAW SAFETY RULES

- **Provide auxiliary workpiece support to the rear and/or sides of the saw table for long and/or wide workpieces to keep them level.** A long and/or wide workpiece has a tendency to pivot on the table's edge, causing loss of control, saw blade binding and kickback.
- **Feed workpiece at an even pace. Do not bend or twist the workpiece. If jamming occurs, turn the tool off immediately, unplug the tool then clear the jam.** Jamming the saw blade by the workpiece can cause kickback or stall the motor.
- **Do not remove pieces of cut-off material while the saw is running.** The material may become trapped between the fence or inside the saw blade guard and the saw blade pulling your fingers into the saw blade. Turn the saw off and wait until the saw blade stops before removing material.
- **Use an auxiliary fence in contact with the table top when ripping workpieces less than 2 mm thick.** A thin workpiece may wedge under the rip fence and create a kickback.

## KICKBACK

Kickback is a sudden reaction of the workpiece due to a pinched, jammed saw blade or misaligned line of cut in the workpiece with respect to the saw blade or when a part of the workpiece binds between the saw blade and the rip fence or other fixed object.

Most frequently during kickback, the workpiece is lifted from the table by the rear portion of the saw blade and is propelled towards the operator.

Kickback is the result of saw misuse and/or incorrect operating procedures or conditions and can be avoided by taking proper precautions as given below.

- **Never stand directly in line with the saw blade. Always position your body on the same side of the saw blade as the fence.** Kickback may propel the workpiece at high velocity towards anyone standing in front and in line with the saw blade.
- **Never reach over or in back of the saw blade to pull or to support the workpiece.** Accidental contact with the saw blade may occur or kickback may drag your fingers into the saw blade.
- **Never hold and press the workpiece that is being cut off against the rotating saw blade.** Pressing the workpiece being cut off against the saw blade will create a binding condition and kickback.
- **Align the fence to be parallel with the saw blade.** A misaligned fence will pinch the workpiece against the saw blade and create kickback.
- **Use a featherboard to guide the workpiece against the table and fence when making non-through cuts such as rabbeting, dadoing or resawing cuts.** A featherboard helps to control the workpiece in the event of a kickback.

- **Use extra caution when making a cut into blind areas of assembled workpieces.** The protruding saw blade may cut objects that can cause kickback.
- **Support large panels to minimize the risk of saw blade pinching and kickback.** Large panels tend to sag under their own weight. Support(s) must be placed under all portions of the panel overhanging the table top.
- **Use extra caution when cutting a workpiece that is twisted, knotted, warped or does not have a straight edge to guide it with a miter gauge or along the fence.** A warped, knotted, or twisted workpiece is unstable and causes misalignment of the kerf with the saw blade, binding and kickback.
- **Never cut more than one workpiece, stacked vertically or horizontally.** The saw blade could pick up one or more pieces and cause kickback.
- **When restarting the saw with the saw blade in the workpiece, centre the saw blade in the kerf so that the saw teeth are not engaged in the material.** If the saw blade binds, it may lift up the workpiece and cause kickback when the saw is restarted.
- **Keep saw blades clean, sharp, and with sufficient set. Never use warped saw blades or saw blades with cracked or broken teeth.** Sharp and properly set saw blades minimise binding, stalling and kickback.

## TABLE SAW OPERATION

- **Turn off the table saw and disconnect the power cord when removing the throat plate, changing the saw blade or making adjustments to the riving knife, anti-kickback pawls or blade guard, and when the machine is left unattended.** Precautionary measures will avoid accidents.
- **Never leave the table saw running unattended. Turn it off and don't leave the tool until it comes to a complete stop.** An unattended running saw is an uncontrolled hazard.
- **Locate the table saw in a well-lit and level area where you can maintain good footing and balance. It should be installed in an area that provides enough room to easily handle the size of your workpiece.** Cramped, dark areas, and uneven slippery floors invite accidents.
- **Frequently clean and remove sawdust from under the saw table and/or the dust collection device.** Accumulated sawdust is combustible and may self-ignite.
- **The table saw must be secured.** A table saw that is not properly secured may move or tip over.
- **Remove tools, wood scraps, etc. from the table before the table saw is turned on.** Distraction or a potential jam can be dangerous.
- **Always use saw blades with correct size and shape (diamond versus round) of arbour holes.** Saw blades that do not match the mounting hardware of the saw will run off-centre, causing loss of control.

## TABLE SAW SAFETY RULES



- **Never use damaged or incorrect saw blade mounting means such as flanges, saw blade washers, bolts or nuts.** These mounting means were specially designed for your saw, for safe operation and optimum performance.
- **Never stand on the table saw, do not use it as a stepping stool.** Serious injury could occur if the tool is tipped or if the cutting tool is accidentally contacted.
- **Make sure that the saw blade is installed to rotate in the proper direction. Do not use grinding wheels, wire brushes, or abrasive wheels on a table saw.** Improper saw blade installation or use of accessories not recommended may cause serious injury.

## ADDITIONAL SAFETY RULES







- **Know your power tool.** Read the operator's manual carefully. Learn the saw's applications and limitations as well as the specific potential hazards related to this tool.
- **Make workshop childproof with padlocks and master switches, or by removing starter keys.**
- **Use the proper extension cord.** Make sure your extension cord is in good condition. Use only a cord heavy enough to carry the current your product will draw. An undersized cord will cause a drop in line voltage resulting in loss of power and overheating. A wire gauge size (A.W.G.) of at least **14** is recommended for an extension cord 25 feet or less in length. If in doubt, use the next heavier gauge. The smaller the gauge number, the heavier the cord.
- **Always wear eye protection with side shields marked to comply with ANSI Z87.1.** Failure to do so could result in objects being thrown into your eyes, resulting in possible serious injury.
- **Secure work.** Use clamps or a vise to hold work when practical. It's safer than using your hand and frees both hands to operate tool.
- **Use recommended accessories.** Consult the operator's manual for recommended accessories. The use of improper accessories may risk injury.
- **Use only correct blades.** Do not use blades with incorrect size holes. Never use blade washers or blade bolts that are defective or incorrect. The maximum blade capacity of your saw is 10 in. (254 mm).
- **Check damaged parts.** Before further use of the tool, a guard or other part that is damaged should be carefully checked to determine that it will operate properly and perform its intended function. Check for alignment of moving parts, binding of moving parts, breakage of parts, mounting and any other conditions that may affect its operation. A guard or other part that is damaged must be properly repaired or replaced by an authorized service center to avoid risk of personal injury.
- **Never leave tool running unattended. Turn the power off.** Don't leave tool until it comes to a complete stop.
- **Protect your lungs.** Wear a face or dust mask if the cutting operation is dusty.
- **Protect your hearing.** Wear hearing protection during extended periods of operation.
- **When operating a power tool outside, use an outdoor extension cord marked "W-A" or "W".** These cords are rated for outdoor use and reduce the risk of electric shock.
- **Always keep the blade guard and riving knife (splitter) in place and in working order.**
- **Keep hands away from cutting area.** Keep hands away from blades. Do not reach underneath work or around or over the blade while blade is rotating. Do not attempt to remove cut material when blade is moving.
- **Avoid awkward operations and hand positions where a sudden slip could cause your hand to move into the blade.**
- **Do not reach behind the blade with either hand from either side of the saw blade, to support the workpiece, remove wood scraps, or for any other reason while the blade is spinning.**
- **The table saw must be mounted to a firm supporting surface, such as a workbench or leg stand that positions the saw at waist height.** In addition, provide adequate support such as auxiliary tables, roller support tables, outfeed supports, etc. when cutting heavy, wide, or long. Heavy, wide, or long workpieces can tip if not securely supported. If the cut-off piece or workpiece tips, it can lift the blade guard or be thrown by the spinning blade.
- **If the workpiece or blade becomes jammed, turn the table saw off.** Wait for all moving parts to stop and disconnect the plug from the power source. Then work to free the jammed material. After the material is removed, verify that the blade is parallel to the miter gauge groove, and the riving knife and blade are aligned. If the jam occurred during a rip cut, verify that the rip fence is parallel to the blade. Adjust if necessary.

# SYMBOLS

The following signal words and meanings are intended to explain the levels of risk associated with this product.

| SYMBOL  | SIGNAL          | MEANING  |
|---|-----------------|--|
|  | <b>DANGER:</b>  | Indicates a hazardous situation, which, if not avoided, will result in death or serious injury.  |
|  | <b>WARNING:</b> | Indicates a hazardous situation, which, if not avoided, could result in death or serious injury.   |
|  | <b>CAUTION:</b> | Indicates a hazardous situation, that, if not avoided, may result in minor or moderate injury.   |
|   | <b>NOTICE:</b>  | (Without Safety Alert Symbol) Indicates information considered important, but not related to a potential injury (e.g. messages relating to property damage). |

Some of the following symbols may be used on this tool. Please study them and learn their meaning. Proper interpretation of these symbols will allow you to operate the tool better and safer.

| SYMBOL  | NAME                   | DESIGNATION/EXPLANATION  |
|---|------------------------|--|
|   | Safety Alert           | Indicates a potential personal injury hazard.  |
|  | Read Operator's Manual | To reduce the risk of injury, user must read and understand operator's manual before using this product. |
|  | Eye Protection         | Always wear eye protection with side shields marked to comply with ANSI Z87.1.                           |
|  | No Hands Symbol        | Failure to keep your hands away from the blade will result in serious personal injury.                   |
|  | Wet Conditions Alert   | Do not expose to rain or use in damp locations.  |
| V   | Volts                  | Voltage  |
| A   | Amperes                | Current  |
| Hz  | Hertz                  | Frequency (cycles per second)  |
| min   | Minutes                | Time   |
| ~   | Alternating Current    | Type of current  |
| $n_0$   | No Load Speed          | Rotational speed, at no load   |
|  | Class II Construction  | Double-insulated construction  |
| .../min   | Per Minute             | Revolutions, strokes, surface speed, orbits, etc., per minute  |

# ELECTRICAL

## DOUBLE INSULATION

Double insulation is a concept in safety in electric power tools, which eliminates the need for the usual three-wire grounded power cord. All exposed metal parts are isolated from the internal metal motor components with protecting insulation. Double insulated tools do not need to be grounded.

### **WARNING:**

The double insulated system is intended to protect the user from shock resulting from a break in the tool's internal wiring. Observe all normal safety precautions to avoid electrical shock.

**NOTE:** Servicing of a product with double insulation requires extreme care and knowledge of the system and should be performed only by a qualified service technician. For service, we suggest you return the tool to your nearest authorized service center for repair. Always use original factory replacement parts when servicing.

## ELECTRICAL CONNECTION

This tool has a precision-built electric motor. It should be connected to a **power supply that is 120 V, AC only (normal household current), 60 Hz**. Do not operate this tool on direct current (DC). A substantial voltage drop will cause a loss of power and the motor will overheat. If the tool does not operate when plugged into an outlet, double check the power supply.

## POLARIZED PLUGS

See Figure 1.

To reduce the risk of electric shock, this tool has a polarized plug (one blade is wider than the other). This plug will fit in a polarized outlet only one way. If the plug does not fit fully in the outlet, reverse the plug. If it still does not fit, contact a qualified electrician to install the proper outlet. Do not change the plug in any way.

## EXTENSION CORDS

When using a power tool at a considerable distance from a power source, be sure to use an extension cord that has the capacity to handle the current the product will draw. An undersized cord will cause a drop in line voltage, resulting in overheating and loss of power. Use the chart to determine the minimum wire size required in an extension cord. Only round jacketed cords listed by Underwriter's Laboratories (UL) should be used.

When working outdoors with a product, use an extension cord that is designed for outside use. This type of cord is designated with "WA" or "W" on the cord's jacket.

Before using any extension cord, inspect it for loose or exposed wires and cut or worn insulation.

\*\*Ampere rating (on tool faceplate)

| Cord Length | Wire Size (A.W.G.) |         |         |         |          |           |
|-------------|--------------------|---------|---------|---------|----------|-----------|
|             | 0-2.0              | 2.1-3.4 | 3.5-5.0 | 5.1-7.0 | 7.1-12.0 | 12.1-16.0 |
| 25'         | 16                 | 16      | 16      | 16      | 14       | 14        |
| 50'         | 16                 | 16      | 16      | 14      | 14       | 12        |
| 100'        | 16                 | 16      | 14      | 12      | 10       | —         |

\*\*Used on 12 gauge - 20 amp circuit.

**NOTE:** AWG = American Wire Gauge

### **WARNING:**

Keep the extension cord clear of the working area. Position the cord so that it will not get caught on lumber, tools or other obstructions while you are working with a power tool. Failure to do so can result in serious personal injury.

### **WARNING:**

Check extension cords before each use. If damaged replace immediately. Never use product with a damaged cord since touching the damaged area could cause electrical shock resulting in serious injury.

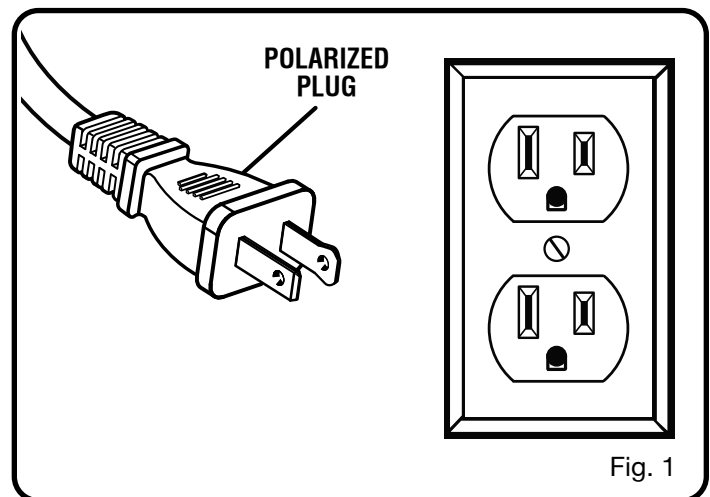

# GLOSSARY OF TERMS

## **Anti-Kickback Pawls (radial arm and table saws)**

A device which, when properly installed and maintained, is designed to stop the workpiece from being kicked back toward the front of the saw during a ripping operation.

## **Arbor**

The shaft on which a blade or cutting tool is mounted.

## **Bevel Cut**

A cutting operation made with the blade at any angle other than 90° to the table surface.

## **Chamfer**

A cut removing a wedge from a block so the end (or part of the end) is angled rather than at 90°.

## **Compound Cut**

A cross cut made with both a miter and a bevel angle.

## **Cross Cut**

A cutting or shaping operation made across the grain or the width of the workpiece.

## **Cutter Head (planers and jointer planers)**

A rotating cutterhead with adjustable blades or knives. The blades or knives remove material from the workpiece.

## **Dado Cut (table saws and compound sliding miter saws)**

A non-through cut which produces a square, three-sided notch or trough in the workpiece.

## **Featherboard (table saws)**

A device used to help control the workpiece by guiding it securely against the table or fence during any ripping operation.

## **FPM or SPM**

Feet per minute (or strokes per minute), used in reference to blade movement.

## **Freehand**

Performing a cut without the workpiece being guided by a fence, miter fence, or other aids.

## **Gum**

A sticky, sap-based residue from wood products.

## **Heel**

Alignment of the blade to the miter gauge groove.

## **Kerf**

The material removed by the blade in a through cut or the slot produced by the blade in a non-through or partial cut.

## **Kickback**

A hazard that can occur when the blade binds or stalls, throwing the workpiece in the direction of the spinning blade.

## **Miter Cut**

A cutting operation made with the workpiece at any angle to the blade other than 90°.

## **Non-Through Cuts (table saws and compound sliding miter saws)**

Any cutting operation where the blade does not extend completely through the thickness of the workpiece. This is a cut where the blade will not cut the workpiece into two pieces.

## **Pilot Hole (drill presses and scroll saws)**

A small hole drilled in a workpiece that serves as a guide for drilling large holes accurately or for insertion of a scroll saw blade.

## **Push Blocks (jointer planers)**

Device used to feed the workpiece over the jointer planer cutterhead during any operation. This aid helps keep the operator's hands well away from the cutterhead.

## **Push Blocks and Push Sticks (table saws)**

Devices used to feed the workpiece through the saw blade during cutting operations. When making a narrow rip cut without a jig or similar cutting aid, always use a push stick (not a push block). A push block can be used for narrow ripping operations, if a jig or similar cutting aid is used. These aids help keep the operator's hands well away from the blade.

## **Rabbet**

A non-through cut positioned on the end or edge of the workpiece which produces a square, two-sided notch or trough in the workpiece.

## **Resaw (table saws and band saws)**

A cutting operation to reduce the thickness of the workpiece to make thinner pieces.

## **Resin**

A sticky, sap-based substance that has hardened.

## **Revolutions Per Minute (RPM)**

The number of turns completed by a spinning object in one minute.

## **Ripping or Rip Cut (table saws)**

A cutting operation along the length of the workpiece and typically in the direction of the grain.

## **Living Knife/Spreader/Splitter (table saws)**

A metal piece, slightly thinner than the blade, which helps keep the kerf open and also helps to prevent kickback.

## **Saw Blade Path**

The area over, under, behind, or in front of the blade. As it applies to the workpiece, that area which will be or has been cut by the blade.

## **Snipe (planers)**

Depression made at either end of a workpiece by cutter blades when the workpiece is not properly supported.

## **Taper Cut**

A cut where the material being cut has a different width at the beginning of the cut from the end.

## **Through Sawing**

Any cutting operation where the blade extends completely through the thickness of the workpiece. This type of cut will separate a single workpiece into two pieces.

## **Workpiece or Material**

The item on which the operation is being done.

## **Worktable**

Surface where the workpiece rests while performing a cutting, drilling, planing, or sanding operation.



# FEATURES

## PRODUCT SPECIFICATIONS

|                      |                       |                            |                 |
|----------------------|-----------------------|----------------------------|-----------------|
| Blade Arbor .....    | 5/8 in.               | Input .....                | 15 Amps         |
| Blade Diameter ..... | 10 in.                | No Load Speed .....        | 5,000/min (RPM) |
| Blade Tilt .....     | 0° - 45°              | Cutting Depth at 0° .....  | 3 in.           |
| Dado Capacity .....  | 1/2 in.               | Cutting Depth at 45° ..... | 2-1/2 in.       |
| Rating .....         | 120 V, AC only, 60 Hz |                            |                 |

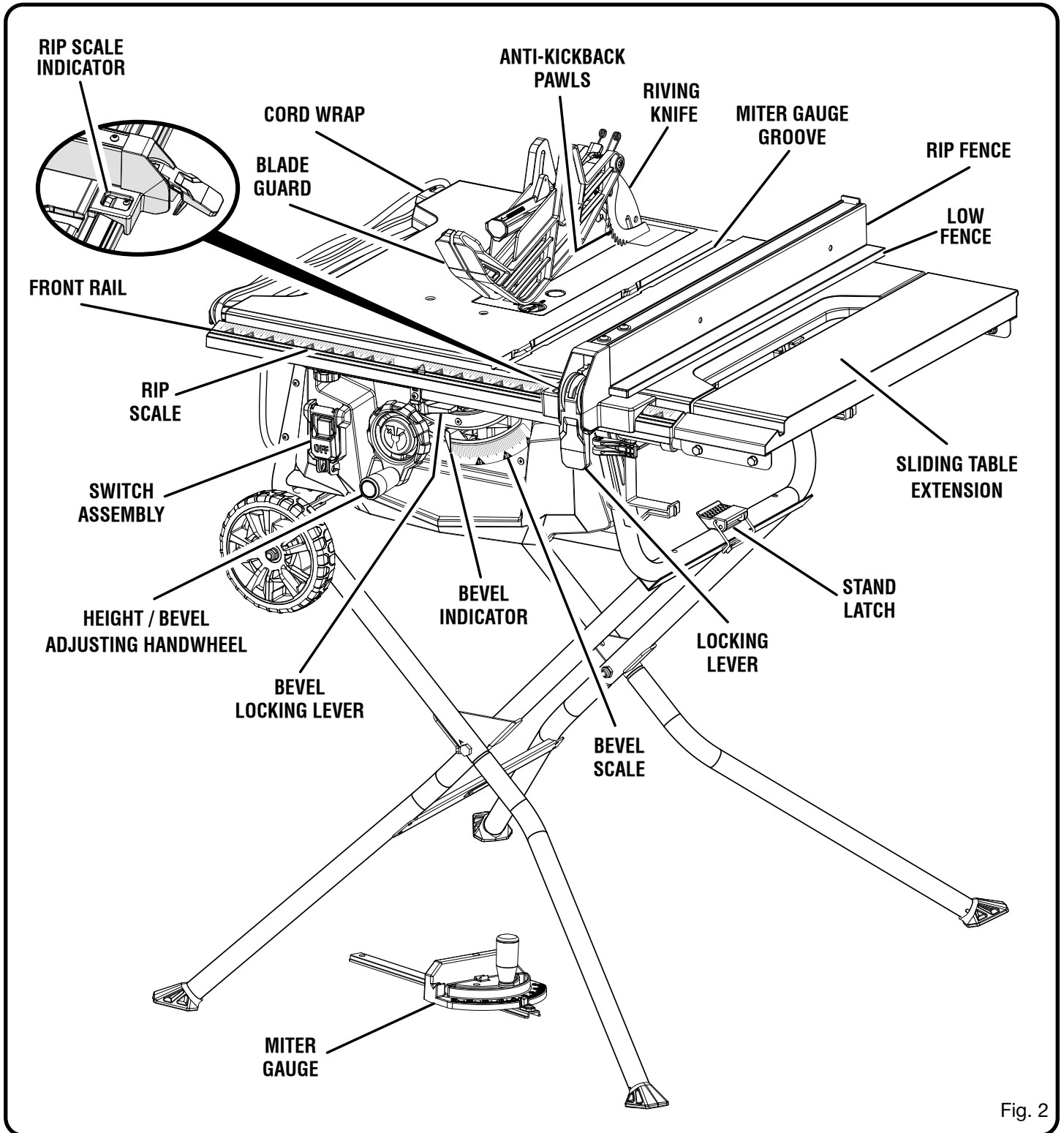

Fig. 2

# FEATURES

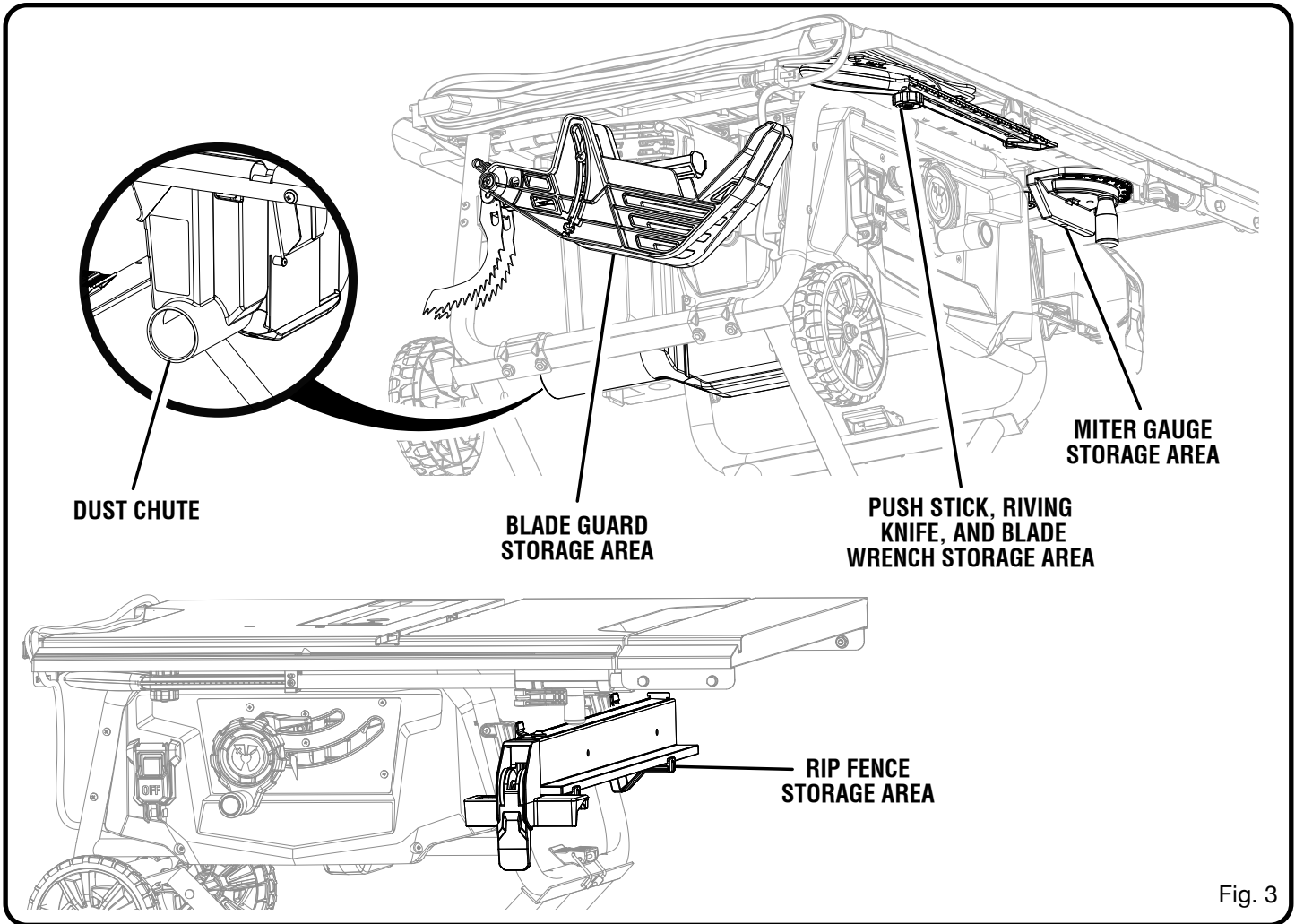

Fig. 3

## KNOW YOUR TABLE SAW

See Figure 2 - 3.

The safe use of this product requires an understanding of the information on the tool and in this operator's manual as well as a knowledge of the project you are attempting. Before use of this product, familiarize yourself with all operating features and safety rules.

**ACCESSORY STORAGE** - Convenient storage areas for the push stick, riving knife, wrenches, blade guard, miter gauge, and rip fence are located underneath the saw table.

**ANTI-KICKBACK PAWLS** - Kickback is a hazard in which the workpiece is thrown back toward the operator. The teeth on the anti-kickback pawls point away from the workpiece. If the workpiece should be pulled back toward the operator, the teeth dig into the wood to help prevent or reduce the possibility of kickback. The anti-kickback pawls may be bypassed.

**BEVEL LOCKING LEVER** - This lever, located just under the saw table surface on the front of the saw, locks the angle setting of the blade.

**BEVEL SCALE** - The easy-to-read scale on the front of the saw shows the exact blade angle.

**BLADE** - For maximum performance, it is recommended that you use the 10 in. carbide tipped combination blade provided with the saw. The blade is raised and lowered with the height/bevel adjusting handwheel. Bevel angles are locked with the bevel locking lever. Additional blade styles of the same high quality are available for specific operations such as ripping. Your local dealer can provide you with complete information. Blade kerf width must be within the limits stamped on the riving knife.

### **⚠ WARNING:**

Do not use blades rated less than the speed of this tool. Failure to heed this warning could result in personal injury.

**BLADE GUARD** - Always keep the removable blade guard down over the saw blade for through-sawing cuts.

**DUST CHUTE** - The built-in dust chute makes it easy to dispose of sawdust. A vacuum hose may be attached to the dust chute.

**ELECTRIC BRAKE** - An electric brake has been provided to stop blade rotation after the saw is turned off.

# FEATURES

**HEIGHT/BEVEL ADJUSTING HANDWHEEL** - Located on the front of the saw, use this handwheel to lower and raise the blade for height adjustments or blade replacement. This handwheel also makes the adjustment for bevel angles easy.

**MITER GAUGE** - The miter gauge aligns the wood for a cross cut. The easy-to-read indicator shows the exact angle for a miter cut.

**MITER GAUGE GROOVE** - The miter gauge rides in the groove on the saw table.

**OUTFEED SUPPORT** - This table extension at the back of the tool gives the operator additional support when cutting long workpieces.

**RIP FENCE** - A sturdy metal fence guides the workpiece and is secured with the locking handle.

**NOTE:** Do not place the rip fence on the left side of the blade when cutting material greater than 3/4 inches thick.

**RIP SCALE** - Located on the front rail, the easy-to-read rip scale provides precise measurements for rip cuts.

**RIVING KNIFE** - A removable metal piece of the blade guard assembly, slightly thinner than the saw blade, which helps keep the kerf open and prevent kickback. When in the through sawing, or “up” position, it is higher than the saw blade. When in the non-through sawing, or “down” position, it is below the saw blade teeth.

**SLIDING TABLE EXTENSION** - Located on the right side of the saw table, this table extension gives the operator additional support when cutting wide workpieces.

**SWITCH ASSEMBLY** - This saw has an easy access switch assembly located below the front rail. To lock the switch, install a padlock (not included) through the holes in the switch and cover. Make certain the switch is inoperable. If the switch is still operable with the padlock installed, a padlock with a larger shackle diameter must be used. Store the padlock key in another location.

## OPERATING COMPONENTS

The upper portion of the blade projects up through the table and is surrounded by an insert called the throat plate. The height of the blade is set with a handwheel on the front of the saw. Detailed instructions are provided in the *Operation* section of this manual for the basic cuts: cross cuts, miter cuts, bevel cuts, and compound cuts.

The rip fence is used to position work for lengthwise cuts. A scale on the front rail shows the distance between the rip fence and the blade.

It is very important to use the blade guard assembly for all through-sawing operations. The blade guard assembly includes: riving knife and blade guard with anti-kickback pawls.

## SWITCH ASSEMBLY

See Figure 4.

This saw is equipped with an on/off switch that has a built-in locking feature. This feature is intended to prevent unauthorized and possible hazardous use by children and others.

**NOTE:** The switch cover does not have to be raised to operate the switch.

### TO TURN THE SAW ON:

- Press the top button on the switch to turn the saw on.

**NOTE:** If AC power is disconnected or interrupted while the saw is running, the saw will turn off. To restart the saw, restore AC power and press the top of the switch.

### TO TURN THE SAW OFF:

- Press the bottom button on the switch to turn the saw off.

### TO LOCK THE SAW:

- With the saw turned off, install a padlock (not included) through the holes in the switch and switch cover.

### ⚠ WARNING:

**ALWAYS** make sure your workpiece is not in contact with the blade before operating the switch to start the tool. Failure to heed this warning may cause the workpiece to be kicked back toward the operator and result in serious personal injury.

### ⚠ WARNING:

To reduce the risk of accidental starting, always make sure the top button on the switch is not depressed before plugging tool into the power source.

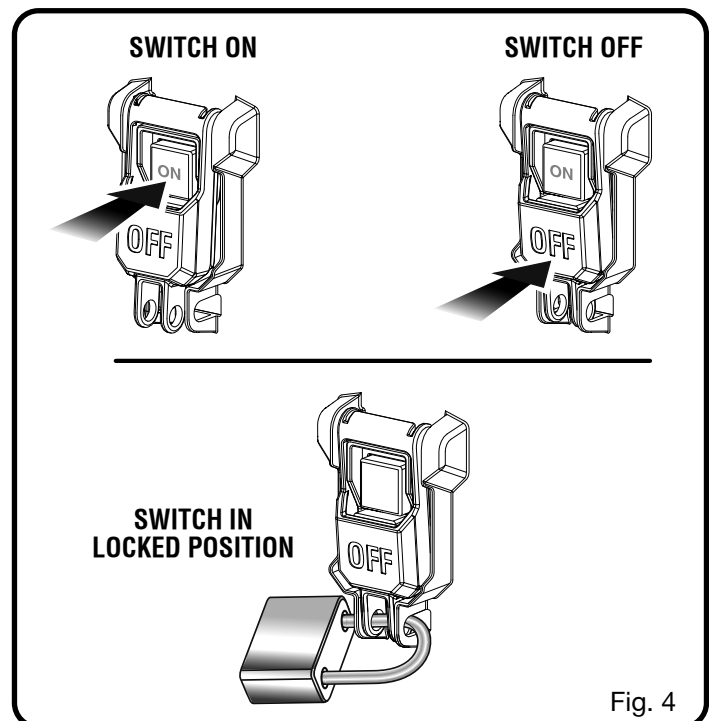

Fig. 4

# TOOLS NEEDED

The following tools (not included or drawn to scale) are needed for assembly and making adjustments:

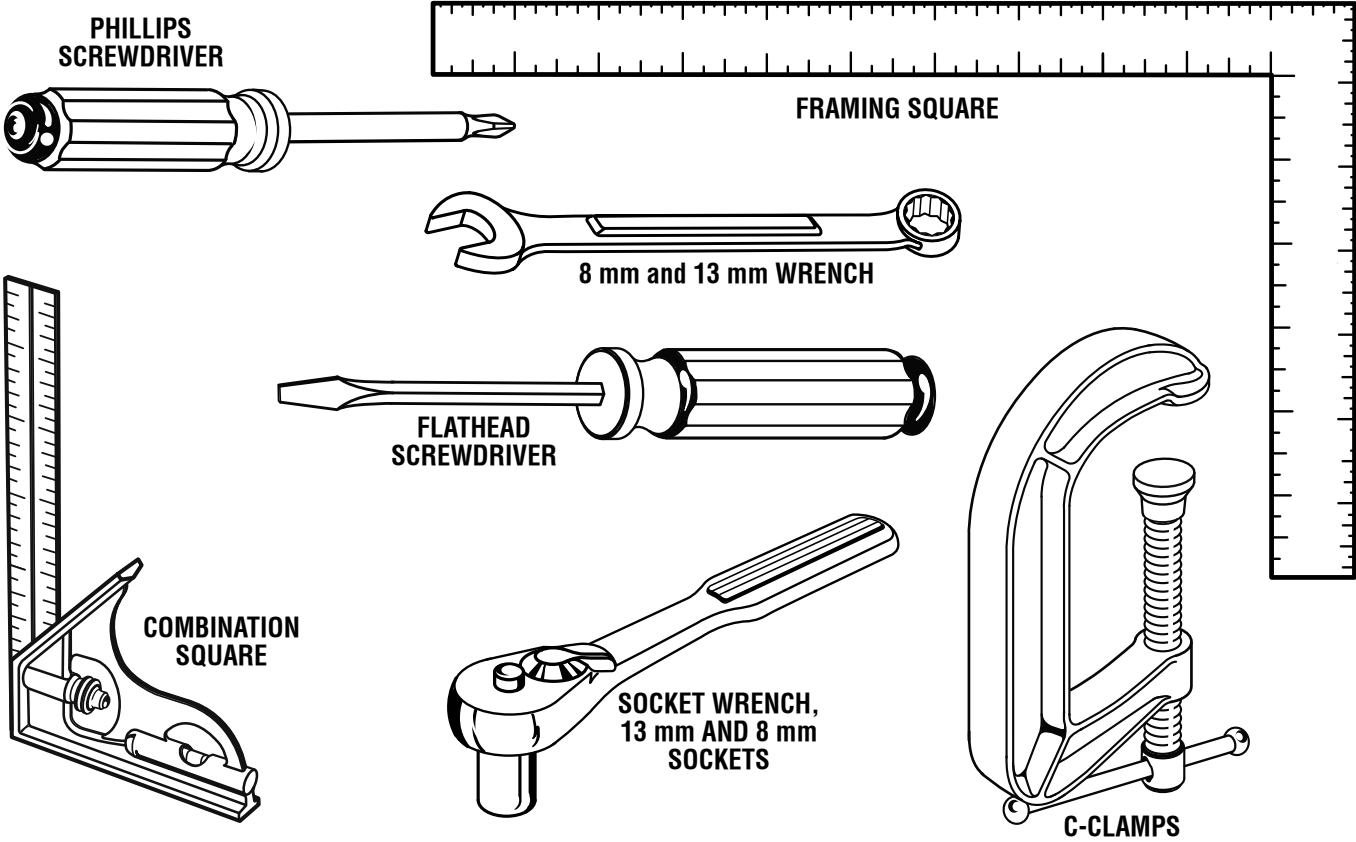

Fig. 5

# LOOSE PARTS

The following items are included with your table saw:

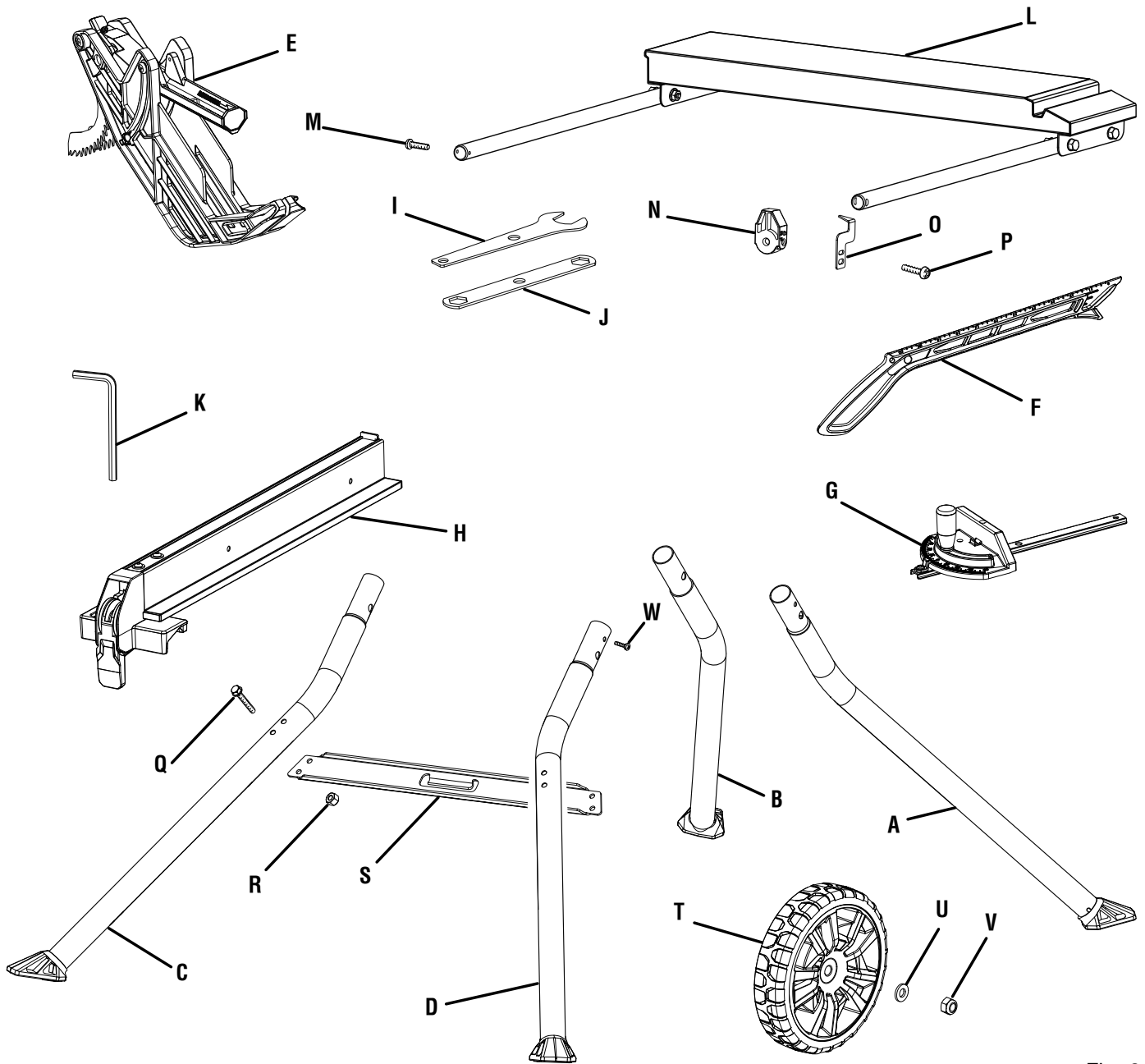

Fig. 6

|  |   |
|--|---|
| A. Front Stand Leg ("A").....                      | 1 |
| B. Rear Stand Leg ("B").....                       | 1 |
| C. Front Stand Leg ("C").....                      | 1 |
| D. Rear Stand Leg ("D").....                       | 1 |
| E. Blade Guard with Anti-Kickback Pawls .....      | 1 |
| F. Push Stick.....                                 | 1 |
| G. Miter Gauge (In Storage Area) .....             | 1 |
| H. Rip Fence.....                                  | 1 |
| I. Open End Blade Wrench (In Storage Area).....    | 1 |
| J. Closed End Blade Wrench (In Storage Area) ..... | 1 |
| K. Hex Key (5 mm).....                             | 1 |
| L. Sliding Table Assembly .....                    | 1 |

|                                       |   |
|---------------------------------------|---|
| M. Stop Screw .....                   | 1 |
| N. Rip Indicator End Cap.....         | 1 |
| O. Indicator .....                    | 1 |
| P. Screw (M4 x 25 mm, Truss Hd.)..... | 1 |
| Q. Bolt (M5 x 35 mm).....             | 4 |
| R. Lock Nut (M5).....                 | 4 |
| S. Crosspiece .....                   | 1 |
| T. Wheel .....                        | 2 |
| U. Washer (OD16 x ID8 x 2t).....      | 4 |
| V. Lock Nut (M8).....                 | 4 |
| W. Self-tapping Screw .....           | 4 |

# ASSEMBLY

## UNPACKING

This product requires assembly.

- Carefully lift saw from the carton and place it on a level work surface.

**NOTE:** This tool is heavy. To avoid back injury, keep your knees bent and lift with your legs, not your back, and get help when needed.

### WARNING:

Do not use this product if any parts on the *Loose Parts* list are already assembled to your product when you unpack it. Parts on this list are not assembled to the product by the manufacturer and require customer installation. Use of a product that may have been improperly assembled could result in serious personal injury.

- Inspect the tool carefully to make sure no breakage or damage occurred during shipping.
- Do not discard the packing material until you have carefully inspected the tool, identified all loose parts, and satisfactorily operated the tool.

**NOTE:** Remove the foam block from between the saw's table and the motor by first beveling the blade, refer to **To Change Blade Angle (Bevel)** in the *Operation* section of this manual.

- The saw is factory set for accurate cutting. After assembling it, check for accuracy. If shipping has influenced the settings, refer to specific procedures explained in this manual.
- If any parts are damaged or missing, please call 1-800-525-2579 for assistance.

### WARNING:

If any parts are damaged or missing, do not operate this tool until the parts are replaced. Use of this with damaged or missing parts could result in serious personal injury.

### WARNING:

Do not attempt to modify this tool or create accessories not recommended for use with this tool. Any such alteration or modification is misuse and could result in a hazardous condition leading to possible serious personal injury.

### WARNING:

Do not connect to power supply until assembly is complete. Failure to comply could result in accidental starting and possible serious personal injury.

### WARNING:

Do not lift the saw without help. Hold it close to your body. Keep your knees bent and lift with your legs, not your back. Ignoring these precautions can result in back injury.

### WARNING:

Never stand directly in line with the blade or allow hands to come closer than 3 in. to the blade. Do not reach over or across the blade. Failure to heed this warning can result in serious personal injury.

### WARNING:

To avoid serious personal injury, always make sure the table saw is securely mounted to a workbench or an approved leg stand. NEVER operate the saw on the floor.

## MOUNTING HOLES

The table saw must be mounted to a firm supporting surface such as a workbench or leg stand. Four bolt holes have been provided in the saw's frame for this purpose.

To mount the saw to a work bench, insert bolts that are of sufficient length to accommodate the saw base, lock washers, hex nuts, and the thickness of the workbench or other mounting surface. Tighten all bolts or screws securely. Carefully check the workbench after mounting to make sure that no movement can occur during use. If any tipping, sliding, or walking is noted, secure the workbench to the floor before operating.

To mount the saw to the leg stand, refer to specific procedures explained later in this section.

# ASSEMBLY

## UNFOLDING THE STAND SUPPORTS

See Figure 7.

**NOTE:** Do not use this leg stand with other equipment or for other purposes.

**NOTE:** During shipping, the foam block between the saw's housing and motor holds the stand leg bolts in place. Remove the foam block before assembling the stand, making sure the bolts remain in place.

- Place the saw on a flat surface with the underside of the saw facing up.
- Cut the zip tie that holds the support brackets together.
- Fold out the stand. Use the latch to secure the free end of the support bracket to the frame of the saw.

## INSTALLING STAND LEGS

See Figure 8 - 9.

Many of the leg stand parts are movable. All hardware must be tightened securely but not so tight that the leg stand won't open and close. For easier assembly, match letter to letter, then install hardware.

### Locate the following parts:

|                          |   |
|--------------------------|---|
| Stand leg.....           | 4 |
| Lock Nut (M8) .....      | 2 |
| Self-tapping Screw ..... | 4 |

- Assemble each side separately. Install all legs with feet pointing outward.
- Carefully remove the bolt from the support bracket while holding the pivot plate in place. Set the bolt aside.
- Insert front stand leg labeled "A" into the end tube of the outer stand support bracket labeled "A" and insert the front stand leg labeled "C" into the end tube of the inner stand support bracket labeled "C". Repeat with rear stand legs labeled "B" and "D".
- Align the hardware holes of the support brackets, legs and pivot plates. Insert the bolt through all pieces and secure

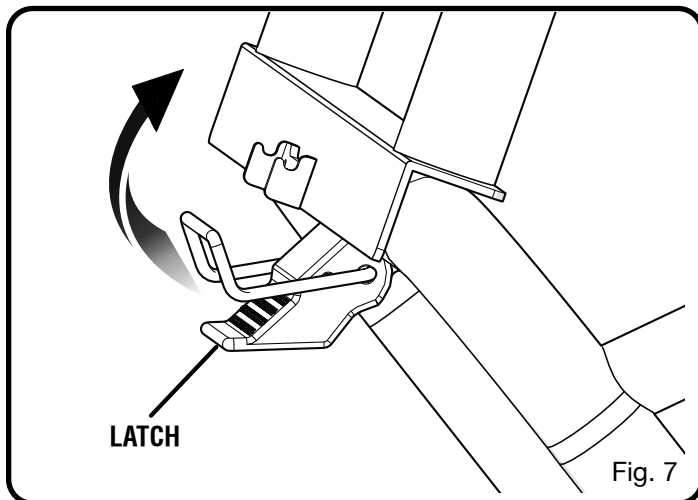

with a lock nut. Tighten the nut using a 13 mm wrench. Then loosen nut slightly to allow legs to pivot freely.

**NOTE:** Do not overtighten as this will not allow the stand to move freely.

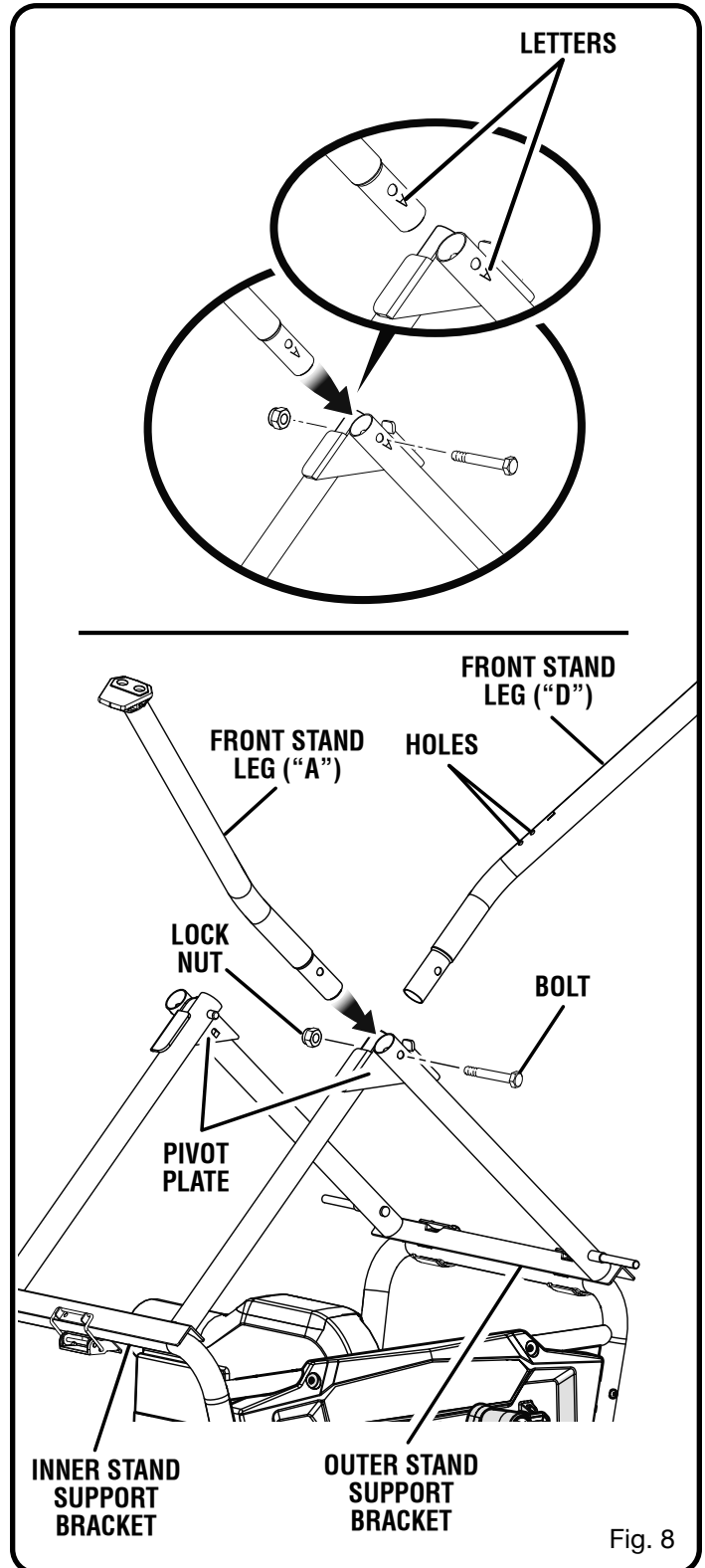

# ASSEMBLY

- Locate the screw holes in the legs, near the pivot plates.
- Using a Phillips screwdriver, insert self-tapping screws through each of the holes.

## INSTALLING THE CROSSPIECE

See Figure 10.

Locate the following parts:

|                         |   |
|-------------------------|---|
| Lock Nut (M5) .....     | 4 |
| Bolt (M5 x 35 mm) ..... | 4 |
| Crosspiece .....        | 1 |

- Place the crosspiece in position as shown, aligning the holes in the crosspiece with the holes in the lower part of the stand.
- Slide each of the four bolts through the holes in the crosspiece and the holes in the legs.
- Place a lock nut over each bolt. Securely tighten the nut using an 8 mm wrench and socket.

## INSTALLING WHEELS ONTO THE STAND

See Figure 11.

Locate the following parts:

|                                |   |
|--------------------------------|---|
| Wheel .....                    | 2 |
| Washer (OD16 x ID8 x 2t) ..... | 4 |
| Lock Nut (M8) .....            | 2 |

- Slide a washer, a wheel, and another washer onto each axle.
- Thread a lock nut onto the axle and securely tighten, using a 13 mm wrench.

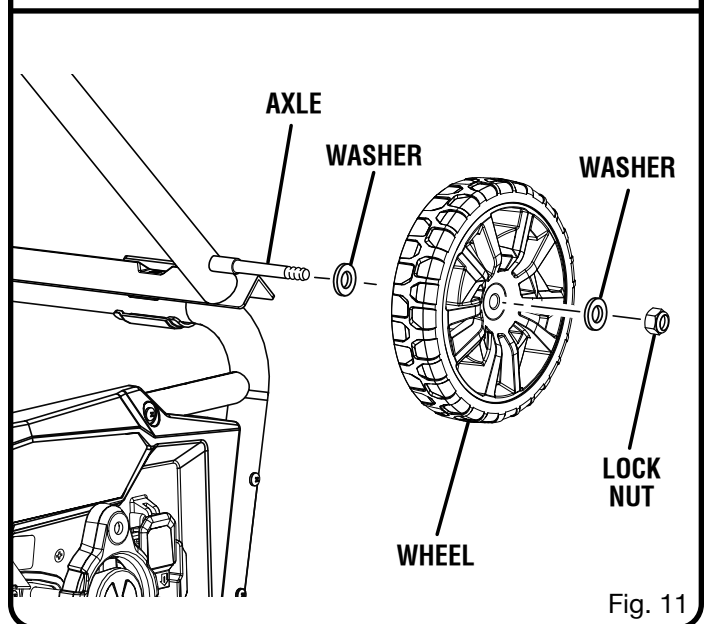
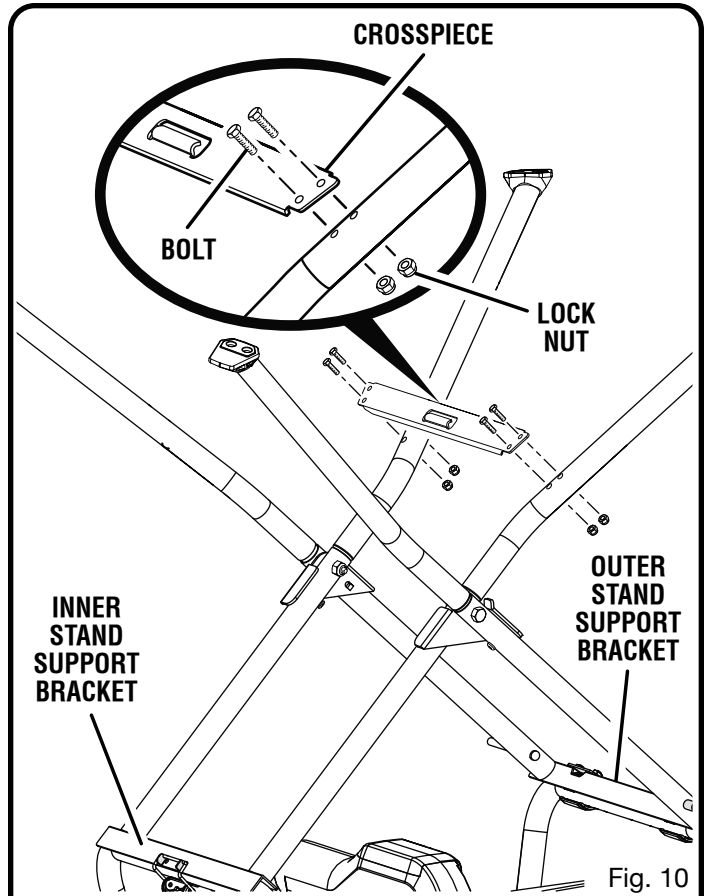
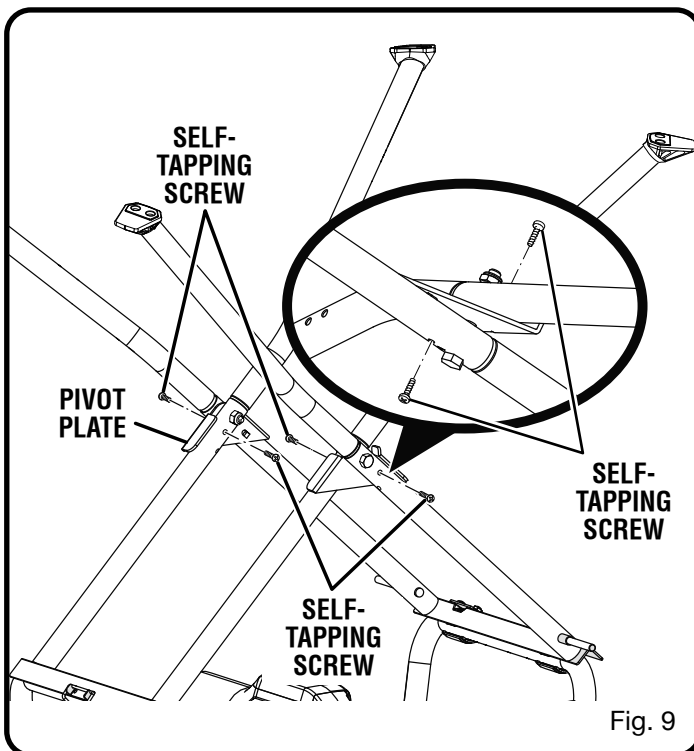



# ASSEMBLY

## INSTALLING THE SLIDING TABLE EXTENSION

See Figures 12 - 14.

### Locate the following parts:

|                                    |   |
|------------------------------------|---|
| Sliding Table Extension.....       | 1 |
| Stop Screw .....                   | 1 |
| Screw (M4 x 25 mm, Truss Hd.)..... | 1 |
| Indicator.....                     | 1 |
| Rip Indicator End Cap .....        | 1 |
| Handle End Cap.....                | 1 |

### To install sliding table extension:

- Unlock the front and back table locking levers on the sliding table extension.
- Insert sliding table extension into table locking levers.
- Push the sliding table extension until it rests against the saw table and is completely closed.
- Install the stop screw into hole on the bottom of the rear extension rod to hold sliding table extension into locking levers.
- Lock the front and back table locking levers.

### To install indicator:

- Press the end cap over the front extension rod (see figure 13).
- Slip the indicator thru the slot in the front rail of the table and into the rip indicator end cap.
- Fit the top slot in the indicator over the detent on the end plug and the bottom slot over the screw hole on the end cap.

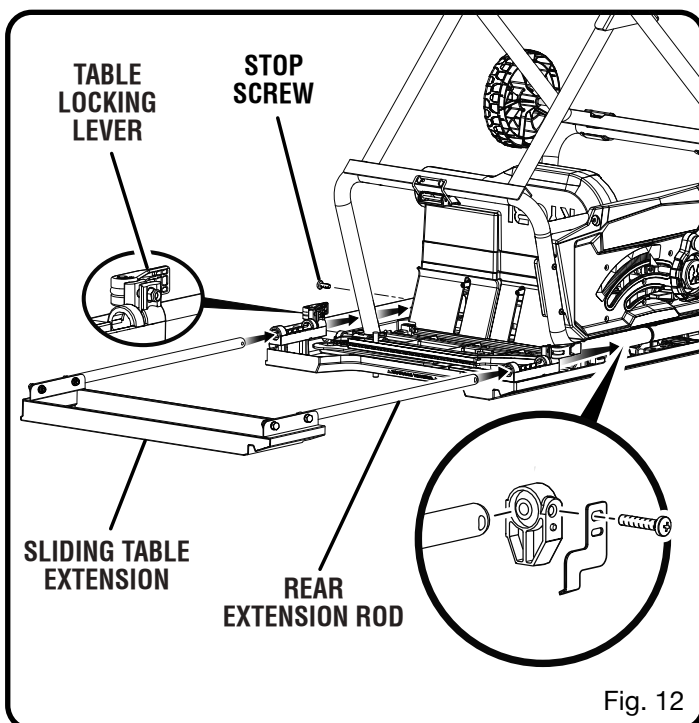

- Insert a screw into the bottom slot of the indicator, the hole in the end cap and the extension rod.
- Align the indicator to the 17 in. mark. Tighten securely, but do not overtighten. Overtightening may crush extension rod ends.

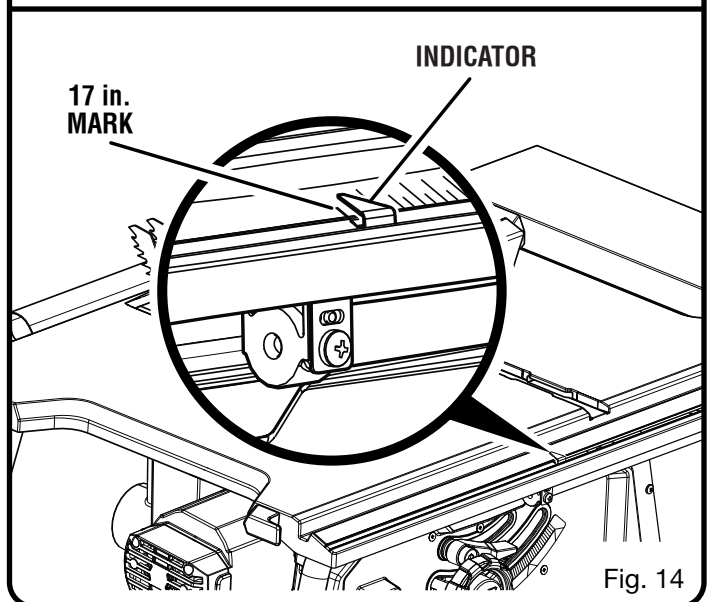
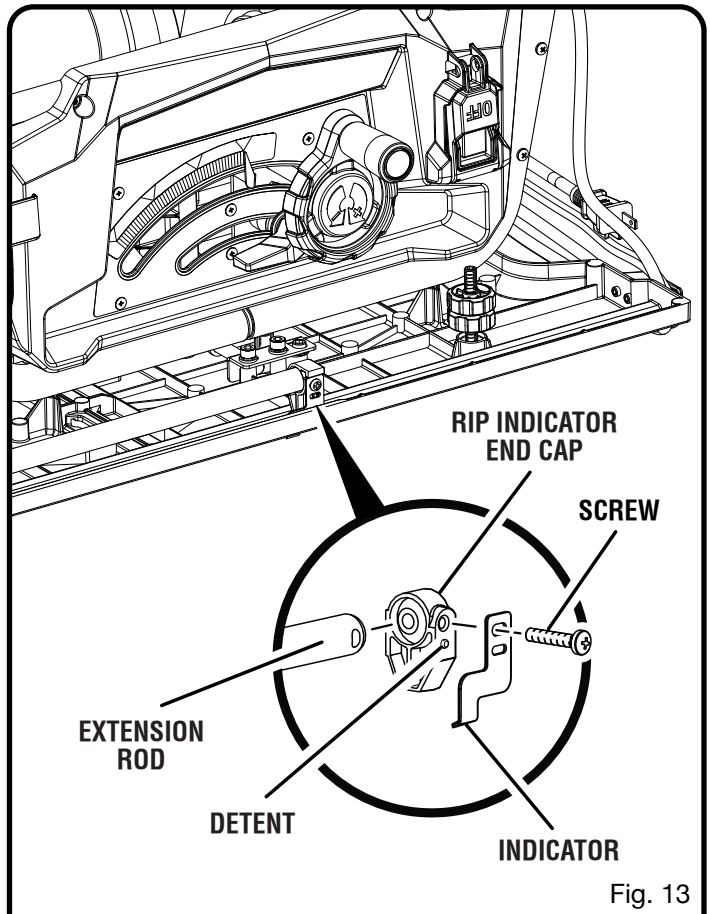

# ASSEMBLY

## TO OPEN/CLOSE (SET-UP/TEAR DOWN) THE LEG STAND

See Figure 15.

**NOTE:** Use the cord wrap on the end of the saw to keep the cord out of the way when setting up or tearing down the saw.

### To open (set-up) the leg stand:

- **Step 1:** Stand the saw on the wheeled end. Open the latch and unhook it from the crosspiece. Lay the leg sections flat.
- **Step 2:** Grasp the inner stand support bracket and lift it until it meets the saw frame. Hook the latch over the inner stand support bracket and push down until the latch locks.

- **Step 3:** Make sure the table extension is in the locked position. Set your right foot against the saw leg to steady it while you push downward on the top leg and lift the saw frame to set the saw upright.

### To close (tear down) the leg stand:

- **Step 1:** Standing to the side of the table saw, place your foot against the foot of the saw. Hold the saw table and grasp the upper saw leg. Make sure the table extension is in the locked position. Tilt the saw to your left and lower the saw to the floor until it is balanced on end.
- **Step 2:** Open and release the latch. Allow both leg sections to lie flat.
- **Step 3:** Grasp the crosspiece and lift both leg sections so that the crosspiece meets the latch. Hook the latch into the crosspiece and push the latch back until it locks.

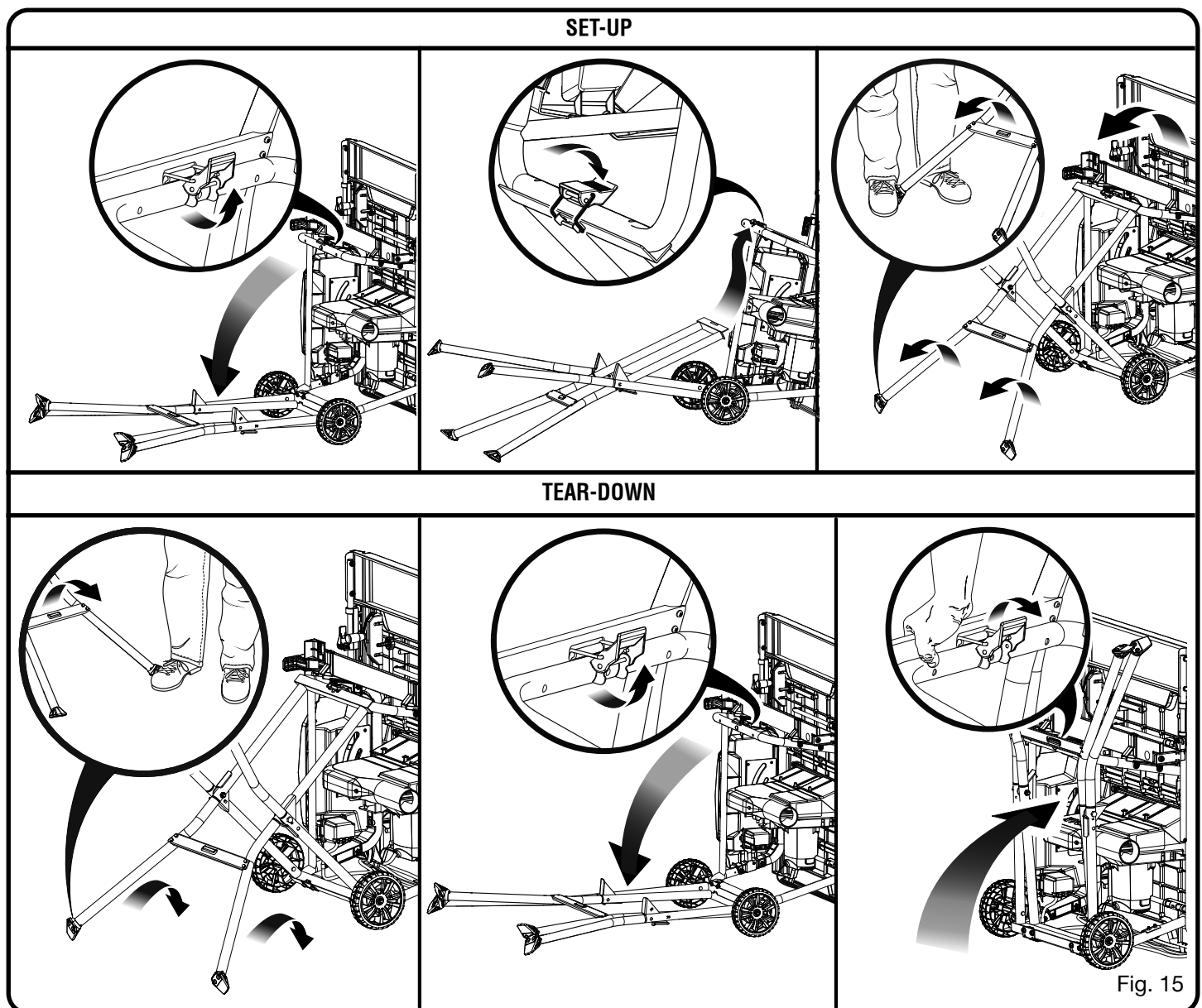

Fig. 15

# ASSEMBLY

## REMOVING/REINSTALLING THE THROAT PLATE

See Figure 16 - 17.

### **⚠ WARNING:**

If the throat plate is too high or too low, the workpiece can catch on the uneven edges resulting in binding or kickback which could result in serious personal injury. Verify the throat plate is correctly seated. Before turning on the saw, perform a dry run of the cutting operation to make sure that no problems will occur when the cut is made. If the workpiece catches, do not attempt to use the saw. Contact customer service for assistance.

- Lower the blade by turning the height/bevel adjusting handwheel counterclockwise.
- To remove the throat plate, rotate the knob to the unlocked position. Place your index finger into the hole, lift and pull the throat plate out toward the front of the saw.
- To reinstall the throat plate, rotate the knob to the unlocked position. Place throat plate back onto the saw and rotate the knob to the locked position.

**NOTE:** The throat plate may move up and down over time. If necessary, use a Phillips screwdriver to adjust the screws located under the throat plate until it is level with the saw table.

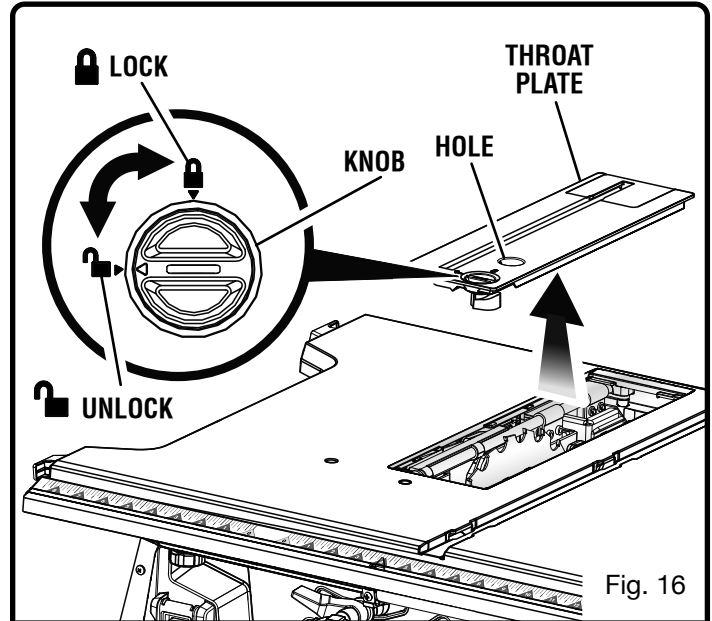

Fig. 16

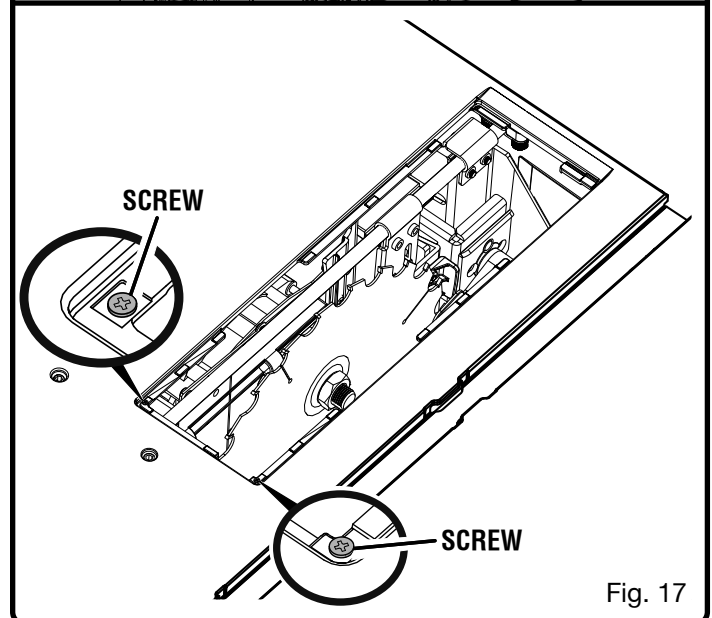

Fig. 17

# ASSEMBLY

## CHANGING RIVING KNIFE POSITIONS

See Figure 18.

This saw is shipped with a riving knife that should be placed in the “down” position for non-through cutting and must be placed in the “up” position for all other cutting operations.

### CAUTION:

Use caution when reaching inside the throat in the saw table. Blade contact, even when the blade is still, may result in injury to hands or arms.

- Unplug the saw.

#### To place in the “up” position for all through cutting:

- Remove the throat plate.
- Raise the saw blade by turning the height/bevel adjusting handwheel clockwise.
- Unlock the release lever by pulling it up.
- Grasp the riving knife and pull it towards the right side of the saw to release the riving knife from the spring-loaded riving clamp.
- Pull the riving knife up until the internal pins are engaged and the riving knife is above the saw blade.
- Lock the release lever by pushing the lever down.

### WARNING:

Make sure the release lever is fully seated. If the release lever is difficult to lock, thoroughly clean lever components using compressed air or a clean soft cloth as described in the **Cleaning the Riving Knife Lock Lever Plates** section in *Maintenance*. Failure to completely lock the release lever can allow the riving knife to change position during saw use, which could result in serious personal injury.

- Reinstall the throat plate.

#### To place in the “down” position for all non-through cutting:

- Remove the throat plate.
- Raise the saw blade by turning the height/bevel adjusting handwheel clockwise.
- Unlock the release lever by pulling it up.

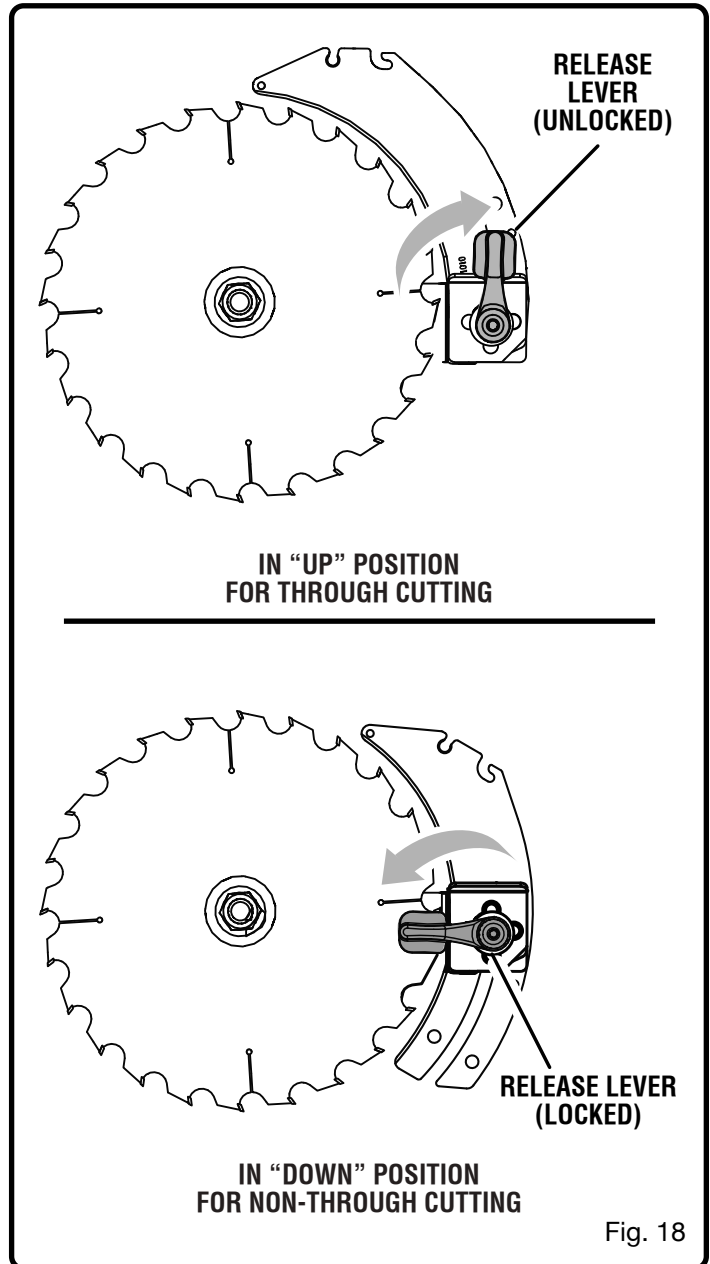

- Grasp the riving knife and pull it towards the right side of the saw to release the riving knife from the spring-loaded riving clamp.
- Push the riving knife down until it is below the saw blade.
- Lock the release lever by pushing the lever down.
- Reinstall the throat plate.

# ASSEMBLY

## CHECKING SAW BLADE INSTALLATION

See Figure 19.

### NOTICE:

To work properly, the saw blade teeth must point down toward the front of the saw. Failure to heed this warning could cause damage to the saw blade, the saw, or the workpiece.

- Unplug the saw.
- Remove the blade wrench from the blade wrench storage area.
- Lower the saw blade and remove the throat plate.
- Raise the saw blade to its full height by turning the height/bevel adjusting handwheel clockwise.
- Make sure the bevel locking lever is locked. (See figure 38.)
- Place riving knife in the “up” position.

### To loosen the blade:

- Place the flat open end of the open end blade wrench on the flats on the arbor shaft.
- Insert the closed end blade wrench over the blade nut. Holding both wrenches firmly, pull the closed end wrench forward to the front of the machine.

**NOTE:** Arbor shaft has right-hand threads.

### To tighten the blade:

- Place the flat open end of the open end blade wrench on the flats on the arbor shaft.
- Insert the closed end blade wrench over the blade nut. Holding both wrenches firmly, push the closed end wrench to the back of the machine. Make sure the blade nut is securely tightened. Do not overtighten.

**NOTE:** Arbor shaft has right-hand threads.

- Reinstall the throat plate.
- Check all clearances for free blade rotation.

After installation, adjust the rip scale indicator to account for the kerf and thickness of the blade. Refer to **To Set the Rip Fence Scale Indicator to the Blade** in the *Operation* section of this manual. In cutting operations, the scale will be set to the side of the blade where the cut will be measured and made.

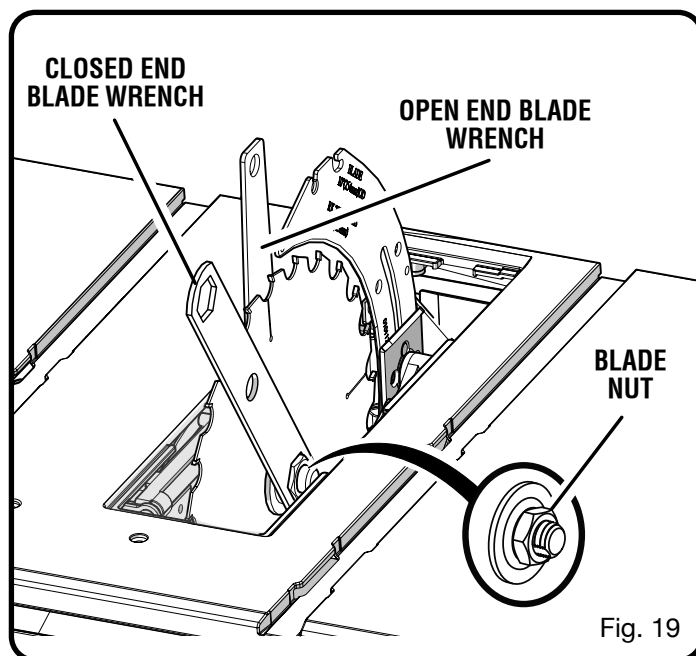

# ASSEMBLY

## INSTALLING THE BLADE GUARD

See Figures 20 - 21.

### **⚠ WARNING:**

Always install the blade guard onto the riving knife in the “up” position to provide proper blade coverage. Installing the guarding components onto the riving knife in any other position will prevent them from working as designed, which could increase the risk of serious personal injury.

### **⚠ WARNING:**

Replace the blade guard if the anti-kickback pawls are dull or damaged. Dull or damaged pawls may not stop a kickback increasing the risk of serious personal injury.

Anti-kickback pawls are part of the blade guard for this saw. They should only be used for through cuts. When not needed, they may be positioned to be out of the way.

- Unplug the saw.
- Raise the saw blade by turning the height/bevel adjusting handwheel clockwise.
- Place riving knife in “up” position.
- Reinstall the throat plate.

### To install blade guard:

- Lift the guard lever up to unlock.
- With the front of the blade guard raised, lower the back of the guard into the riving knife in the position shown. Push the front of the guard down until the bar inside the guard is **parallel to the table** (see figure 20). If the bar is not parallel to the table, the riving knife is not in the “up” position.
- Lock the guard in place by pushing the guard lever down.
- The blade guard side barriers may be lifted, then positioned out of the way without being removed for easier measurement.

**NOTE:** Blade alignment can be adjusted for different kerf widths. Refer to: **To Check and Align the Riving Knife and Saw Blade**. Check the blade guard assembly for clearances and free movement.

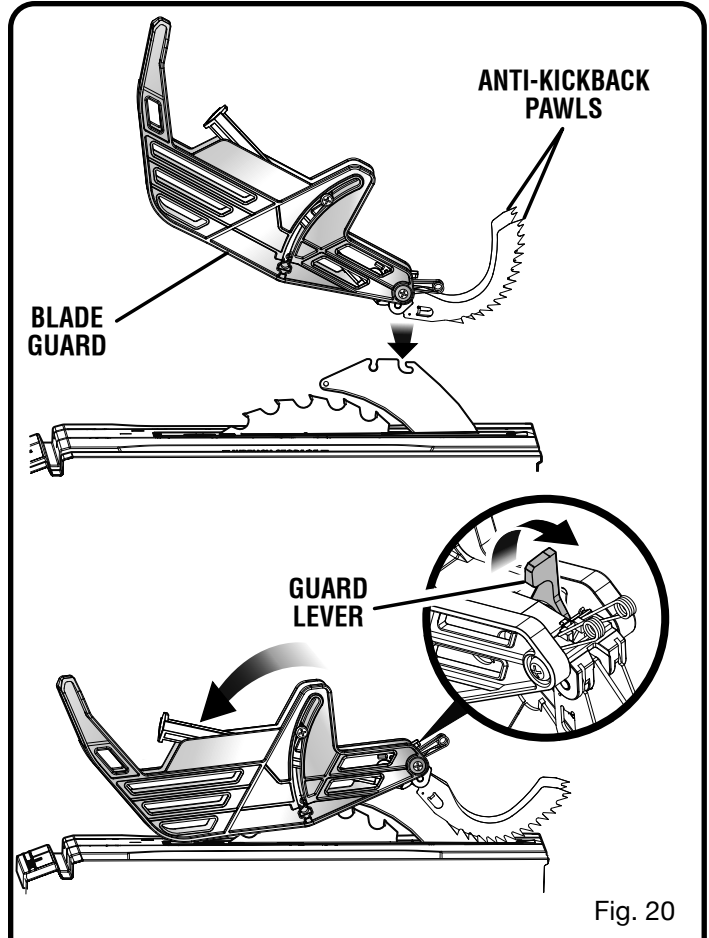

Fig. 20

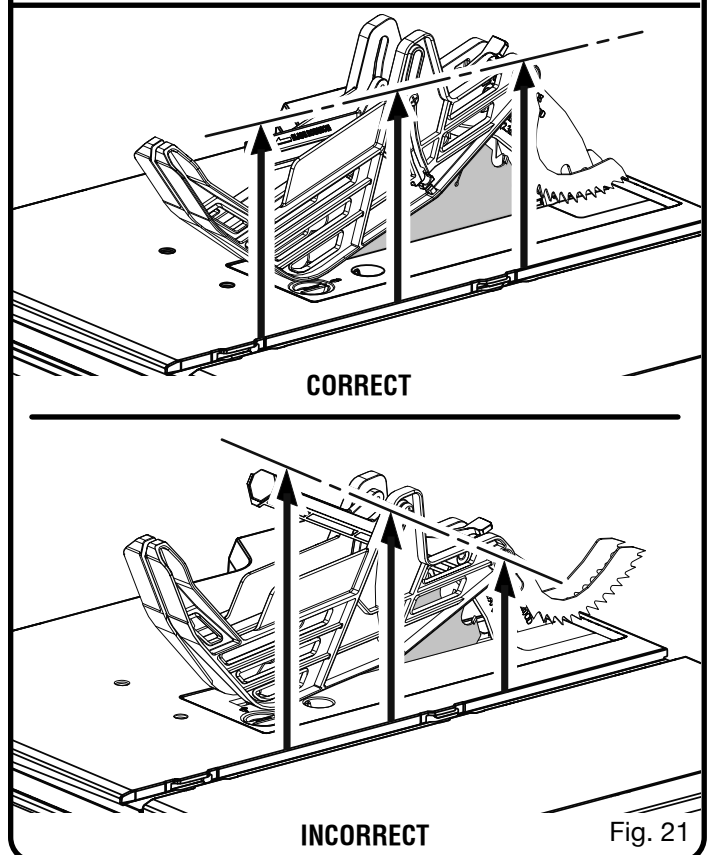

Fig. 21

# ASSEMBLY

## TO CHECK AND ALIGN THE RIVING KNIFE AND SAW BLADE

See Figures 22 - 23.

### To check alignment of the riving knife:

- Unplug the saw.
- Raise the saw blade to its full height.
- Remove the blade guard.
- To check horizontal alignment, place a framing square or straight edge against both the body of the saw blade and the riving knife. The framing square should contact both the blade body and riving knife evenly with no gaps. Check the alignment with both sides of the blade body.
- **NOTE:** The kerf or width of each tooth is wider than the blade body. When the riving knife is properly aligned, it will be centered on the kerf width.
- To check vertical alignment, place a framing square beside the riving knife. The edge of the square and the riving knife should be parallel.

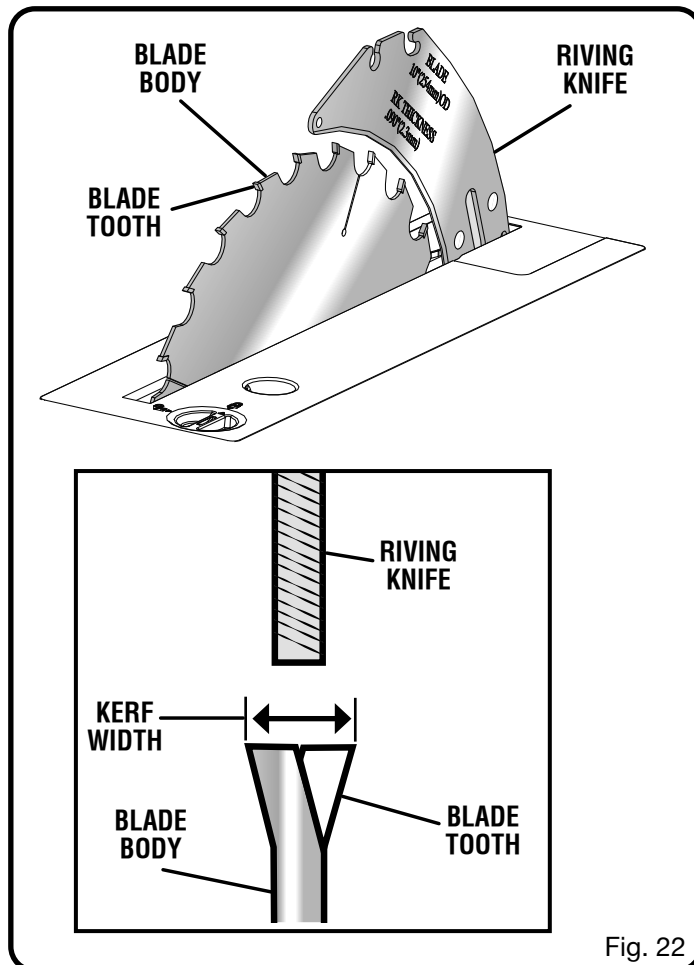

Fig. 22

If the riving knife is out of alignment with the saw blade, adjustment is needed. The riving knife must be in alignment front to back (horizontally) and top to bottom (vertically).

### To adjust (horizontally and vertically):

- Raise the saw blade to its full height.
- Remove the blade guard.
- From the back of the saw, loosen the screws holding the mounting bracket.
- Reposition the riving knife left or right as needed to align the riving knife with the saw blade.
- Once properly aligned, securely retighten all screws.
- Check again for squareness and continue to adjust if needed.

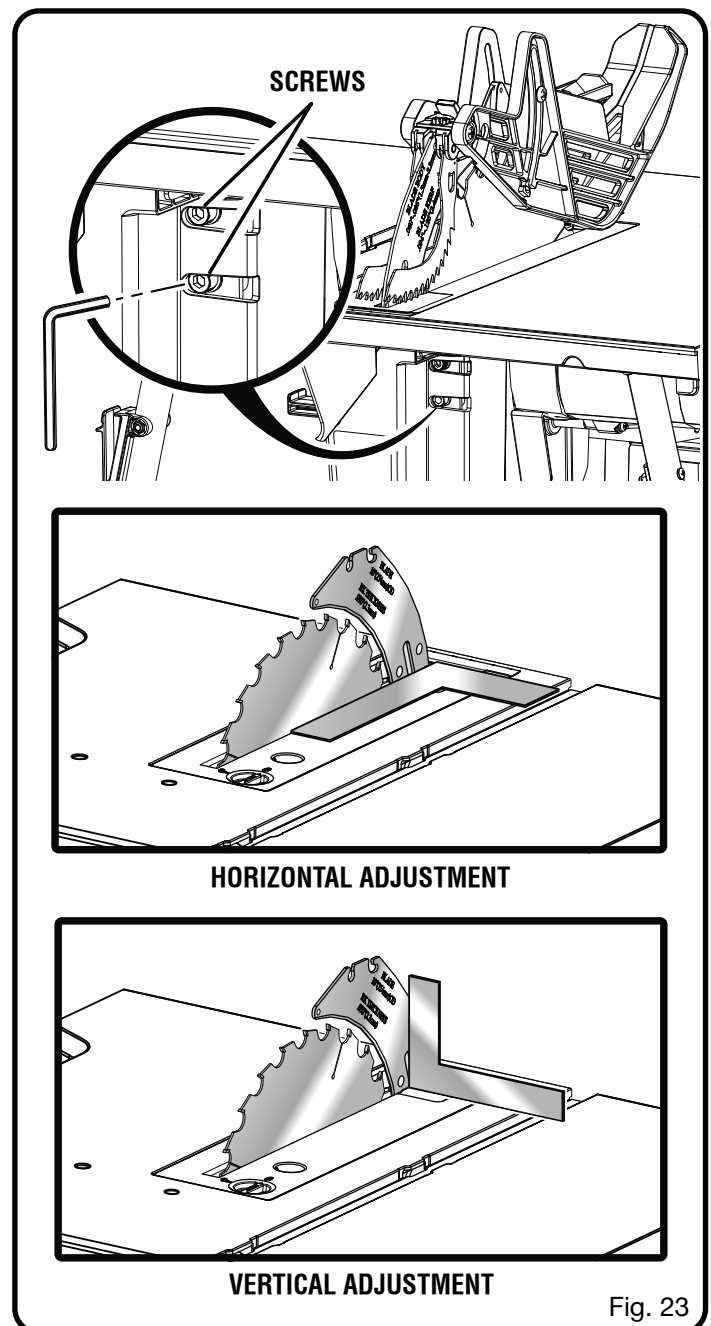

Fig. 23

# ASSEMBLY

## TO MOVE THE SAW

See Figure 24.

- Close the leg stand as described earlier in the **To open/close (set-up/tear down) the leg stand** section.
- Holding the leg stand firmly, pull the leg stand toward you until the leg stand and saw are balanced on the wheels like a handtruck.
- Push the saw to the desired location then either open the leg stand for immediate saw operation or store the saw in a dry environment.

## STORING TABLE SAW ACCESSORIES

See Figure 25 - 28.

When not in use the rip fence, riving knife, wrenches, blade guard, miter gauge, and push stick may be stored beneath the saw table.

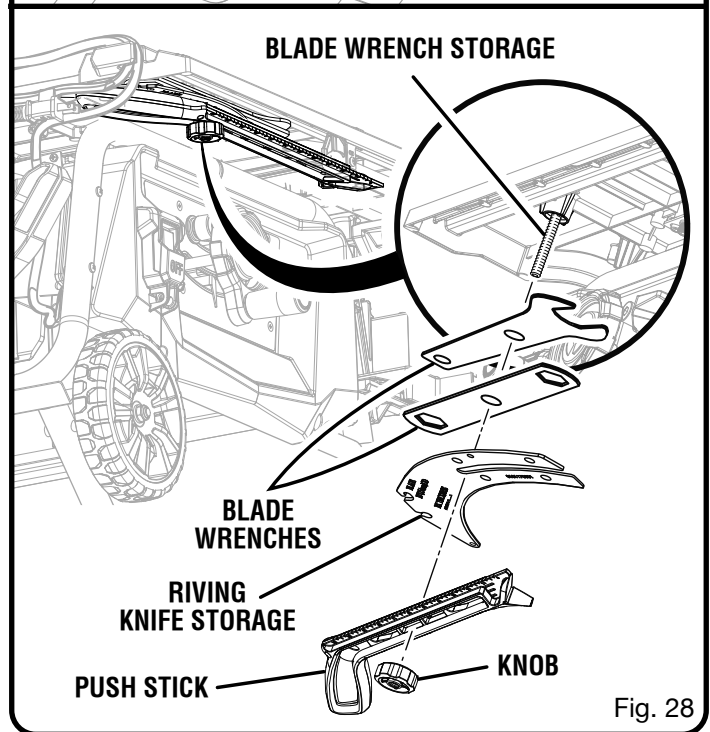
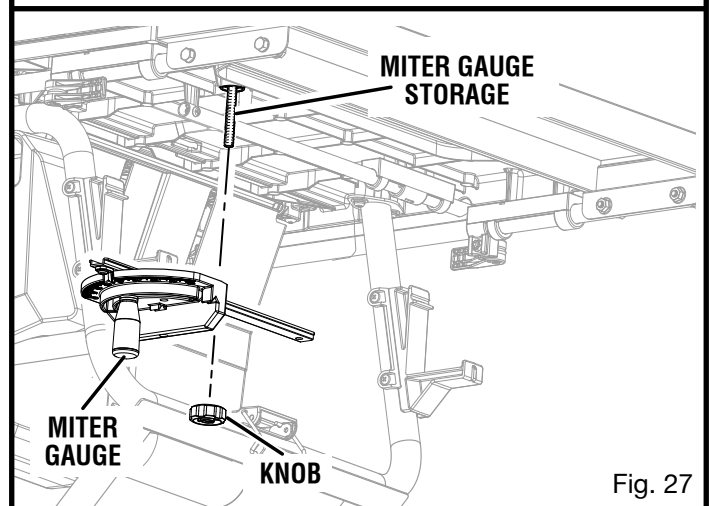
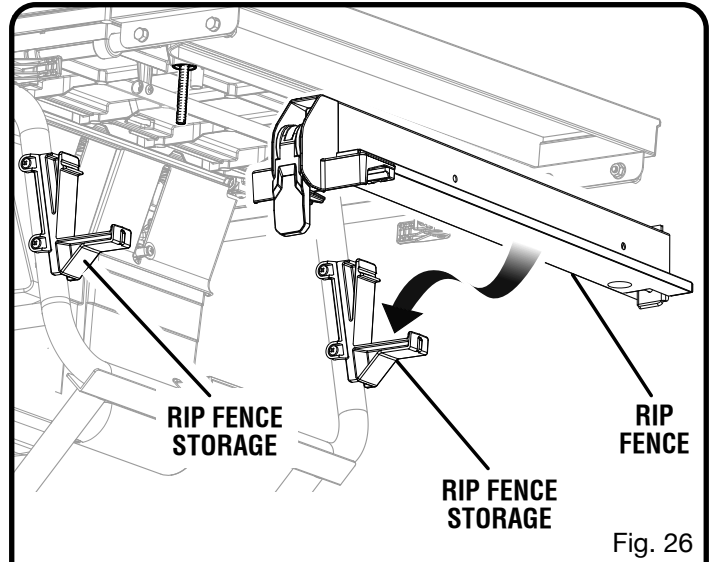
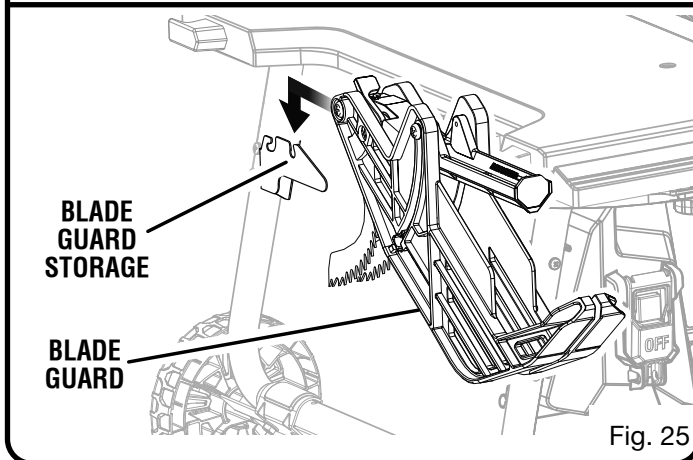
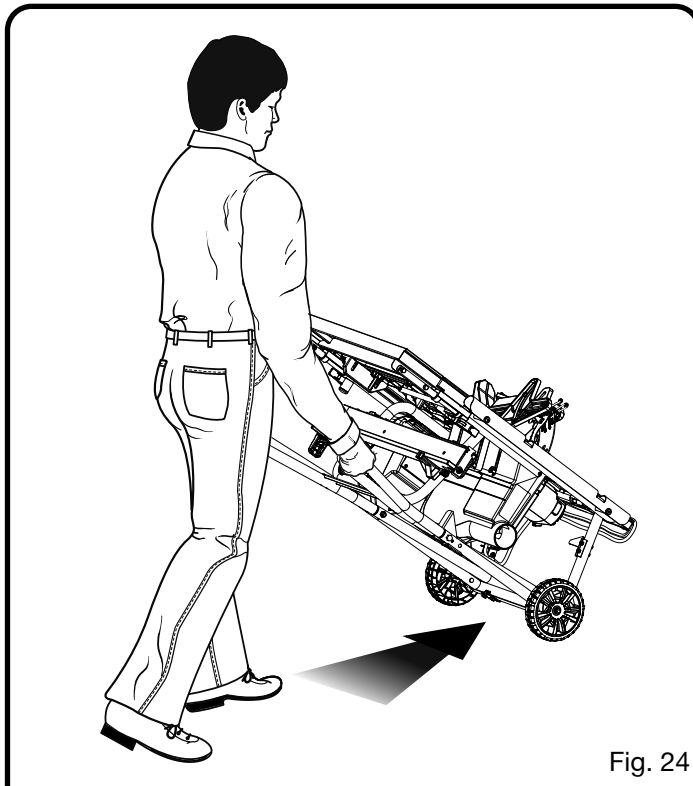



# OPERATION

## WARNING:

Do not allow familiarity with tools to make you careless. Remember that a careless fraction of a second is sufficient to inflict severe injury.

## WARNING:

Always wear eye protection with side shields marked to comply with ANSI Z87.1. Failure to do so could result in objects being thrown into your eyes, resulting in possible serious injury.

## WARNING:

Do not use any attachments or accessories not recommended by the manufacturer of this tool. The use of attachments or accessories not recommended can result in serious personal injury.

## WARNING:

Although many of the illustrations in this manual are shown with the blade guard removed for clarity, do not operate the saw without the blade guard unless specifically instructed to do so.

## WARNING:

The table saw must be mounted to a firm supporting surface, such as a workbench or leg stand that positions the saw at waist height. Many illustrations in this manual are shown with the saw unmounted for clarity.

## APPLICATIONS

You may use this tool for the purposes listed below:

- Straight line cutting operations such as cross cutting, ripping, mitering, beveling, and compound cutting
- Dado with optional accessories
- Cabinet making and woodworking

**NOTE:** This table saw is designed to cut wood and wood composition products only.

## BASIC OPERATION OF THE TABLE SAW

To reduce the risk of electric shock, this tool has a polarized plug (one blade is wider than the other). This plug will fit in a polarized outlet only one way. If the plug does not fit fully in the outlet, reverse the plug. If it still does not fit, contact a qualified electrician to install the proper outlet. Do not change the plug in any way. Refer to the *Electrical* section in this manual.

## CAUSES OF KICKBACK

Kickback can occur when the blade stalls or binds, kicking the workpiece back toward you with great force and speed. If your hands are near the saw blade, they may be jerked loose from the workpiece and may contact the blade. Obviously, kickback can cause serious injury, and it is well worth using precautions to avoid the risks.

Kickback can be caused by any action that pinches the blade in the wood such as:

- Making a cut with incorrect blade depth
- Sawing into knots or nails in the workpiece
- Twisting the wood while making a cut
- Failing to support work
- Forcing a cut
- Cutting warped or wet lumber
- Using the wrong blade for the type of cut
- Not following correct operating procedures
- Misusing the saw
- Failing to use the anti-kickback pawls
- Cutting with a dull, gummed-up, or improperly set blade

## AVOIDING KICKBACK

- Always use the correct blade depth setting. The top of the blade teeth should clear the workpiece by 1/8 in. to 1/4 in.
- Inspect the work for knots or nails before beginning a cut. Knock out any loose knots with a hammer. Never saw into a loose knot or nail.
- Always use the rip fence when rip cutting. Use the miter gauge when cross cutting. This helps prevent twisting the wood in the cut.
- Always use clean, sharp, and properly-set blades. Never make cuts with dull blades.
- To avoid pinching the blade, support the work properly before beginning a cut.
- When making a cut, use steady, even pressure. Never force cuts. Do not release the workpiece until you have pushed it completely past the blade.
- Do not cut wet or warped lumber. The workpiece must have a straight edge for it to be guided along the rip fence.
- Use extra caution when cutting some prefinished or composition wood products as the anti-kickback pawls may not always be effective.
- Always guide your workpiece with both hands or with push sticks and/or push blocks. Keep your body in a balanced position to be ready to resist kickback should it occur. Never stand directly in line with the blade.
- Use of a featherboard will help hold the workpiece securely against the saw table or fence.

# OPERATION

- Clean the saw, blade guard, under the throat plate, and any areas where sawdust or scrap workpieces may gather.
- Keep blade guard, riving knife and anti-kickback pawls in place and proper operation. The riving knife must be in alignment with the blade and the pawls must stop a kickback once it has started. Check their operation before ripping.
- Maintain the rip fence parallel with the saw blade.
- When ripping, apply the feed force to the section of the workpiece between the blade and rip fence. Use a push stick and/or push block when appropriate.
- Use the right type of blade for the cut being made.
- Always use the riving knife for every operation where it is allowed. The use of this device will greatly reduce the risk of kickback.

## CUTTING AIDS

See Figures 29 - 30.

Push sticks are devices that may be used for pushing a workpiece through the blade in any rip cut. When making non-through cuts or ripping narrow stock, always use a push stick, push block, and/or featherboard so your hands do not come within 3 inches of the saw blade. They can be made in various sizes and shapes from scrap wood and used in a specific project. The stick must be narrower than the workpiece, with a 90° notch in one end and shaped for gripping on the other end.

A push block has a handle fastened by recessed screws from the underside or secured with wood glue. Use push blocks for narrow cuts and all non-through cuts. A cutting jig or similar cutting aid may be necessary to ensure the push block does not interfere with the cut.

### CAUTION:

Be sure the screws in a push block are recessed to avoid damaging the saw or workpiece.

Push blocks and push sticks like the ones shown in figure 29 can be purchased locally and a push stick is included with your saw. To make additional cutting aids, follow the instructions below.

### To make a push stick:

The material, shape and size of a push stick can vary. For this project, use a piece of solid wood that is 18 in. long, 1-1/2 in. wide and 3/4 in. thick.

- If desired, cut a curve into one end of the workpiece to serve as a grip.
- Cut a notch into the workpiece on the opposite end. During use, this end will contact the edge of the material being cut.

### To make a push block:

The material, shape and size of a push block can vary. For this project, use two pieces of solid wood to make the base and handle. The base is 5 in. long, 3 in. wide and 3/8 in. thick. The handle should be 5 in. long, 1 in. wide, and 3/4 in. thick.

- Mark the center of the base.
- Attach the handle to the center of the base using recessed screws or wood glue.

**NOTE:** To prevent the push block from slipping across the workpiece, you can attach a piece of sandpaper or a non-slip rubber pad to the bottom of the base.

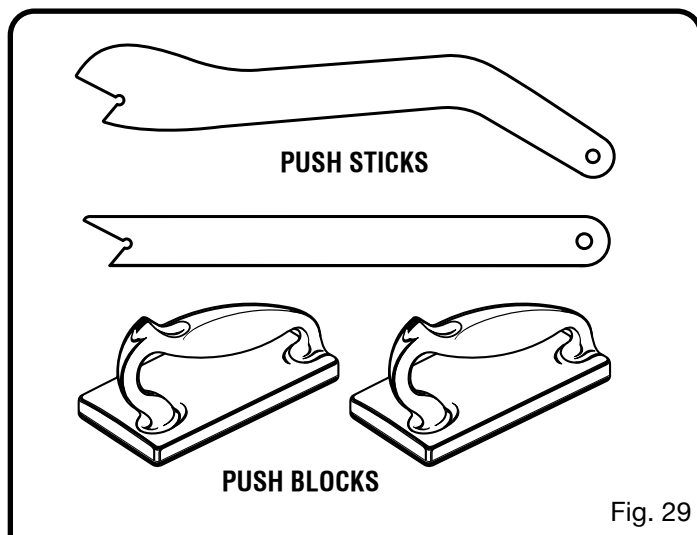

Fig. 29

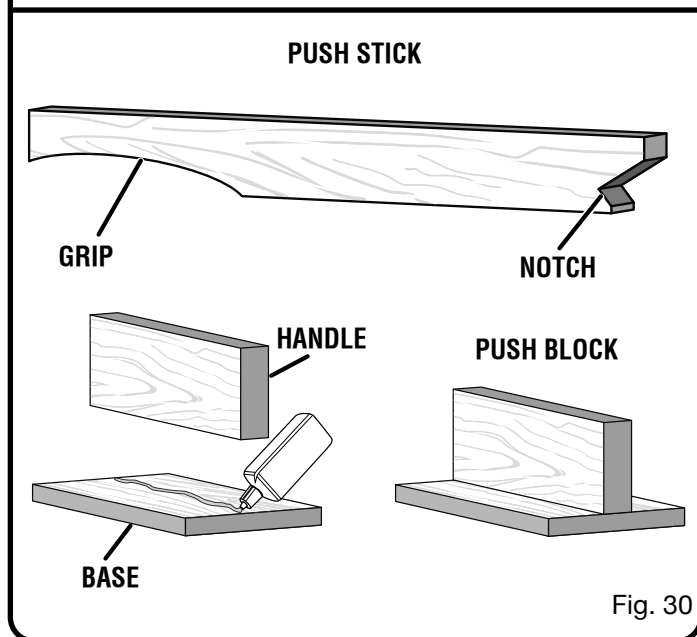

Fig. 30

# OPERATION

## WORKPIECE SUPPORTS

See Figure 31.

When cutting with your table saw, make sure that the workpiece you are cutting is properly supported. Properly supporting the workpiece throughout the cutting process not only improves the accuracy of the cut but also makes the cutting process safer for the user. This support could be required on the infeed side, the overhang side, or the outfeed side of the table. Improper support of the workpiece can cause the workpiece to move in unexpected ways during the process of the cut startling the user of the saw. It may also cause the user to apply abnormal forces to the workpiece to control it during the cutting process. This tipping motion of the workpiece will happen if approximately half of the workpiece overhangs any edge of the saw table.

Appropriate support can be easy to achieve. Commercially available support stands are available, or any surface that is the same height as the work surface of the saw would be acceptable. An operation that is practiced before actually making the cut will inform the user that supports may be necessary for safely completing the saw cut.

## AUXILIARY FENCE

An auxiliary fence is a device used to close the gap between the rip fence and the saw table. Always make and use an auxiliary fence when ripping material 1/8 in. or thinner.

## HOW TO MAKE AND ATTACH AN AUXILIARY FENCE (FOR RIP CUTTING THIN WORKPIECE)

See Figure 32.

An auxiliary fence may be made for the saw by cutting a piece of wood to 21 in. long, at least 3/4 in. thick, and at least 3-1/2 in. tall.

**NOTE:** The height and thickness of the auxiliary fence can be increased depending on the size and type of workpiece you are attempting to cut. Use taller auxiliary fences when cutting workpieces that are taller than the height of the rip fence.

### To attach the auxiliary fence to the rip fence:

- Place the wood against the left side of the rip fence and resting firmly on the saw table.
- From the back side of the rip fence, secure the wood to the fence using wood screws.

**NOTE:** Make sure the screws you use to attach the auxiliary fence do not pass through the front face of the fence.

## HOW TO MAKE A JIG (FOR RIP CUTTING NARROW WORKPIECE)

See Figure 33.

If ripping a narrow workpiece places the hands too close to the blade, it will be necessary to make and use a jig.

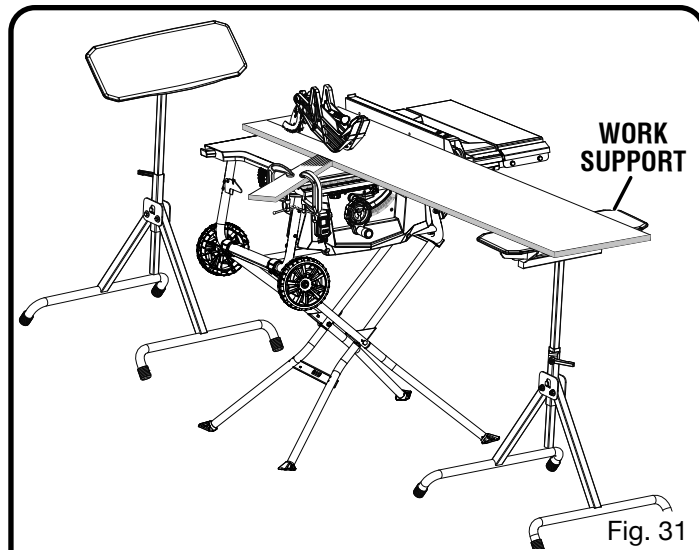

Fig. 31

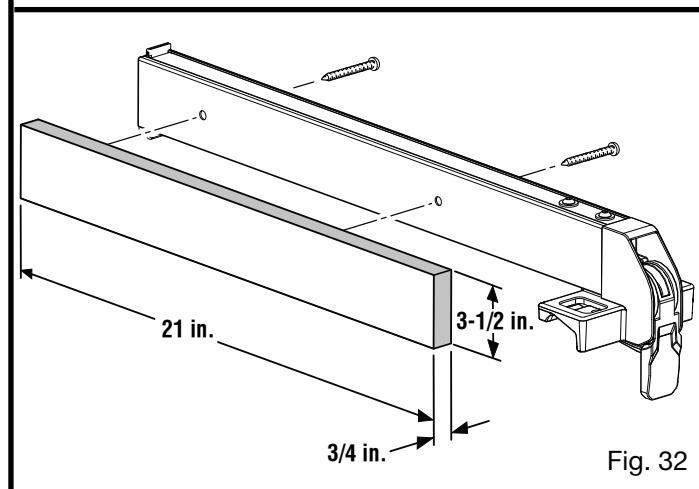

Fig. 32

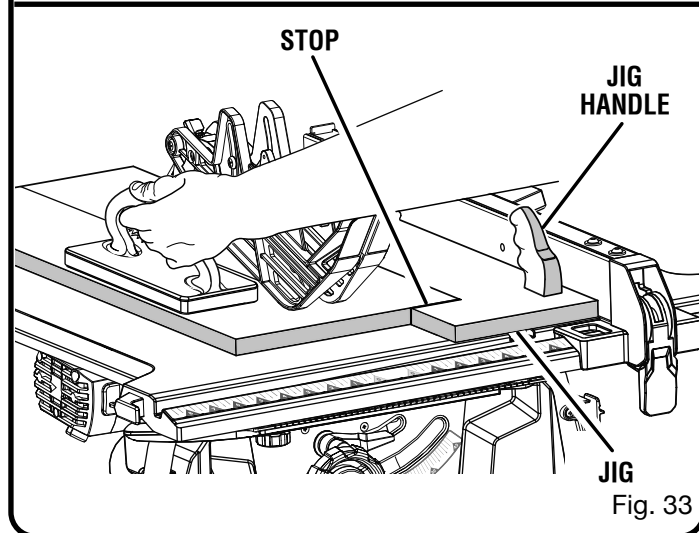

Fig. 33

### To make a jig:

- Attach a handle to a long, straight piece of wood and secure from the underside using recessed screws.
- Cut an L-shaped stop in the side of the jig.

# OPERATION

## To use a jig:

- Position the workpiece flat on the table with the edge flush against the jig and against the stop.
- Holding the jig handle and using a push block and/or push stick make the rip cut, see **Making a Rip Cut** later in this section.

## FEATHERBOARD

A featherboard is a device used to help control the workpiece by holding it securely against the table or fence. Featherboards are especially useful when ripping small workpieces and for completing non-through cuts. The end is angled with a number of short kerfs to give a friction hold on the workpiece and locked in place on the table with a C-clamp. Test to ensure it can resist kickback.

### **⚠ WARNING:**

Place the featherboard against the uncut portion of the workpiece to avoid kickback that could cause serious personal injury.

Commercially available featherboards can be purchased for a reasonable price. Many of these featherboards mount inside the miter slots of the saw and are convenient to mount and use on your table saw. To make a featherboard, follow the instructions in the next section.

## HOW TO MAKE A FEATHERBOARD

See Figure 34.

The featherboard is an excellent project for the saw. Select a solid piece of lumber approximately 3/4 in. thick, 2-1/2 in. wide and 12 in. long. Mark the center of the width on one end of the stock. Miter the width to 70° (see page 39 for information on miter cuts). Mark the board from the widest point at four inches.

Prepare the saw for ripping as discussed on page 37. Set the rip fence to allow approximately a 1/4 in. "finger" to be cut in the stock. Feed the stock only to the mark previously made at 4 in. Turn the saw **OFF** and allow the blade to completely stop

rotating before removing the stock. Reset the rip fence and cut spaced rips into the workpiece to allow approximately 1/4 in. fingers and 1/8 in. spaces between the fingers.

## HOW TO MOUNT A FEATHERBOARD

See Figure 35.

Completely lower the saw blade. Position the rip fence to the desired adjustment for the cut to be performed and lock. Place the workpiece against the fence and over the saw blade area. Adjust the featherboard to apply resistance to the workpiece just forward of the blade. Attach C-clamps to further secure the featherboard to the edge of the saw table.

### **⚠ WARNING:**

The featherboard must be installed in front of the blade. **Do not** locate the featherboard to the rear of the blade. Kickback can result from the featherboard pinching the workpiece and binding the blade in the saw kerf if positioned improperly. Failure to heed this warning can result in serious personal injury.

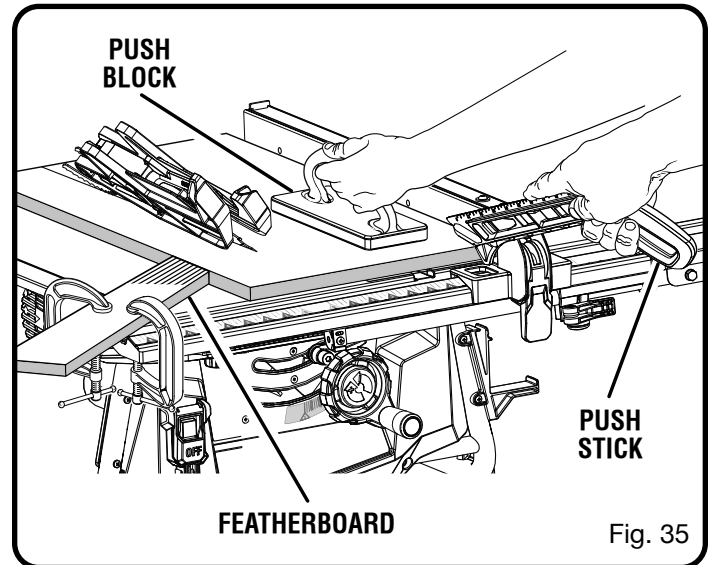

Fig. 35

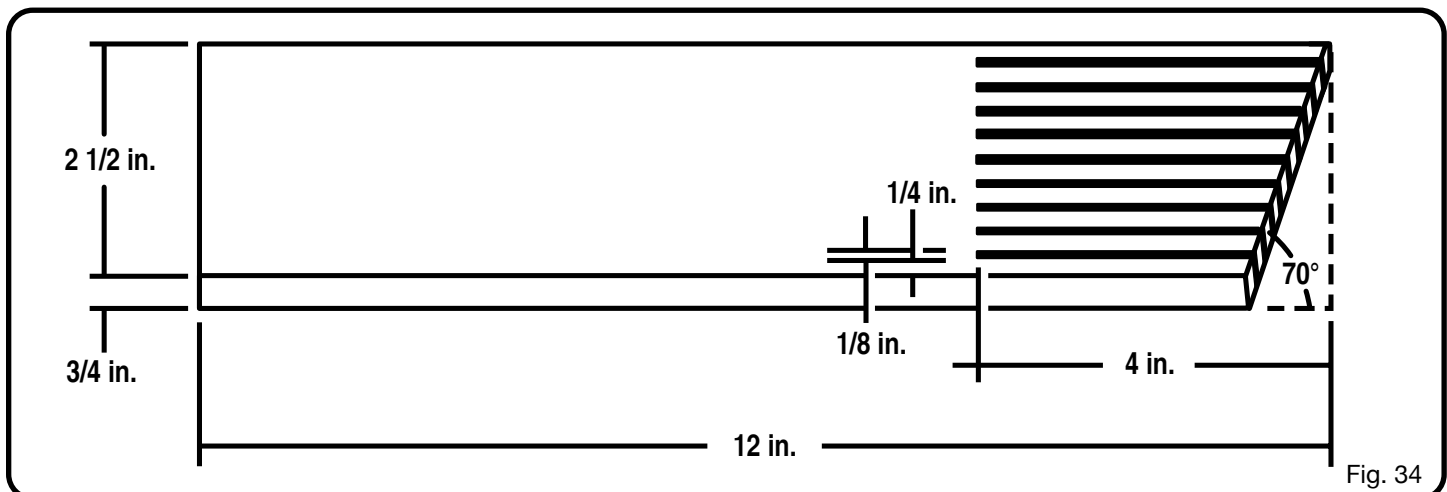

Fig. 34

# OPERATION

## TYPES OF CUTS

See Figure 36.

There are six basic cuts: 1) the cross cut, 2) the rip cut, 3) the miter cut, 4) the bevel cross cut, 5) the bevel rip cut, and 6) the compound (bevel) miter cut. All other cuts are combinations of these basic six. Operating procedures for making each kind of cut are given later in this section.

### **WARNING:**

Always make sure the blade guard is in place and working properly when making these cuts to avoid possible injury.

Cross cuts are straight 90° cuts made across the grain of the workpiece. The wood is fed into the cut at a 90° angle to the blade, and the blade is vertical.

Rip cuts are made with the grain of the wood. To avoid kickback while making a rip cut, make sure one side of the wood rides firmly against the rip fence.

Miter cuts are made with the wood at any angle to the blade other than 90°. The blade is vertical. Miter cuts tend to “creep” during cutting. This can be controlled by holding the workpiece securely against the miter gauge.

### **WARNING:**

Always use a push stick with small pieces of wood, and also to finish the cut when ripping a long narrow piece of wood, to prevent your hands from getting close to the blade.

Bevel cuts are made with an angled blade. Bevel cross cuts are across the wood grain, and bevel rip cuts are with the grain.

Compound (or bevel) miter cuts are made with an angled blade on wood that is angled to the blade. Be thoroughly familiar with making cross cuts, rip cuts, bevel cuts, and miter cuts before trying a compound miter cut.

## CUTTING TIPS

Dado and rabbet cuts are non-through cuts which can be either rip cuts or cross cuts. Carefully read and understand all sections of this operator’s manual before attempting any operation.

### **WARNING:**

Do not use blades rated less than the speed of this tool. Failure to heed this warning could result in personal injury.

- The kerf (the cut made by the blade in the wood) will be wider than the blade to avoid overheating or binding. Make allowance for the kerf when measuring wood.

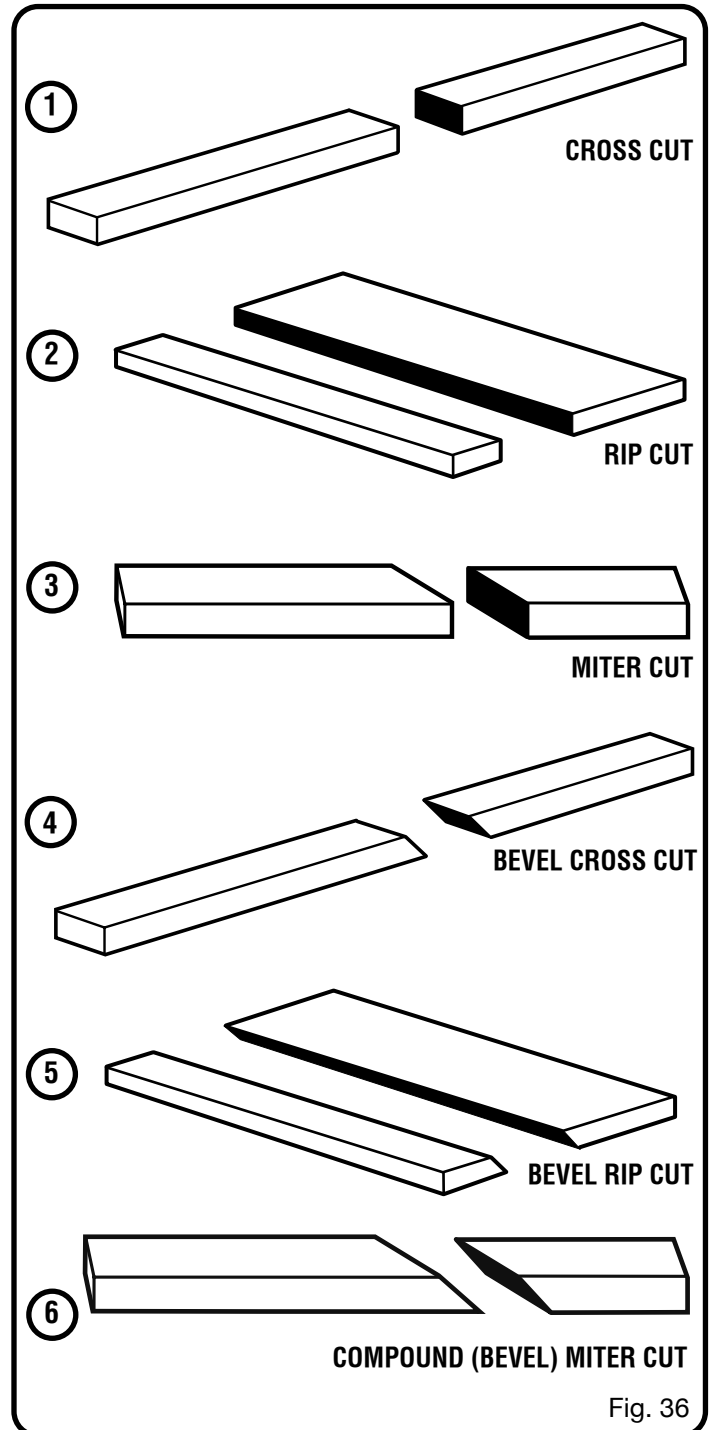

- Make sure the kerf is made on the waste side of the measuring line.
- Cut the wood with the finish side up.
- Knock out any loose knots with a hammer before making the cut.
- Always provide proper support for the wood as it comes out of the saw.

# OPERATION

## TO CHANGE BLADE DEPTH

See Figures 37 - 38.

The blade depth should be set so that the outer points of the blade are higher than the workpiece by approximately 1/8 in. to 1/4 in. but the lowest points (gullets) are below the top surface.

- Turn the bevel lock lever to the right.
- Raise the blade by turning the height/bevel adjusting handwheel clockwise or lower it by turning the handwheel counterclockwise.

## TO CHANGE BLADE ANGLE (BEVEL)

See Figure 38.

This table saw has a rack and pinion bevel control that allows you to make angled cuts from 90° to 45°.

**NOTE:** A 90° cut has a 0° bevel and a 45° cut has a 45° bevel.

- Unplug the saw.
- Loosen bevel control by turning bevel lock lever all the way to the left. If it needs to be further loosened, pull spring-loaded bevel lock lever out and rotate it back to the right. Release bevel locking lever and allow it to seat (lock) in its original position. Turn it to the left again until loose.
- Move the height adjusting handwheel to the right to bevel to 45° bevel angle.
- Tighten bevel control by turning bevel lock lever to the right. If it needs to be tightened more, pull the spring-loaded bevel lock lever out and rotate it to the left. Then release bevel lock lever and allow it to return to its original position. Rotate to the right again. Repeat this process until bevel lock lever is securely tightened.

## TO ADJUST THE BEVEL INDICATOR

See Figure 39.

If the bevel indicator is not at zero when the saw blade is at 90°, adjust the indicator by loosening the screw and setting it at 0° on the bevel scale. Retighten the screw.

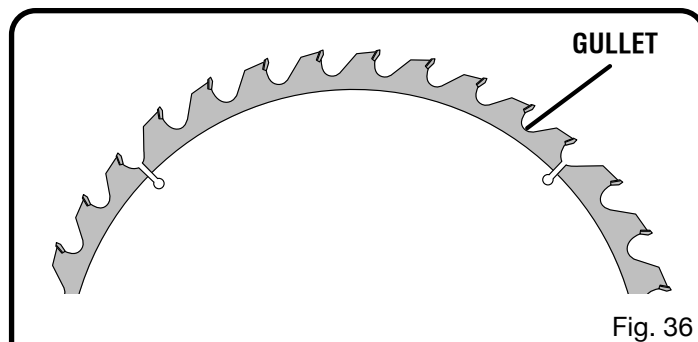

Fig. 36

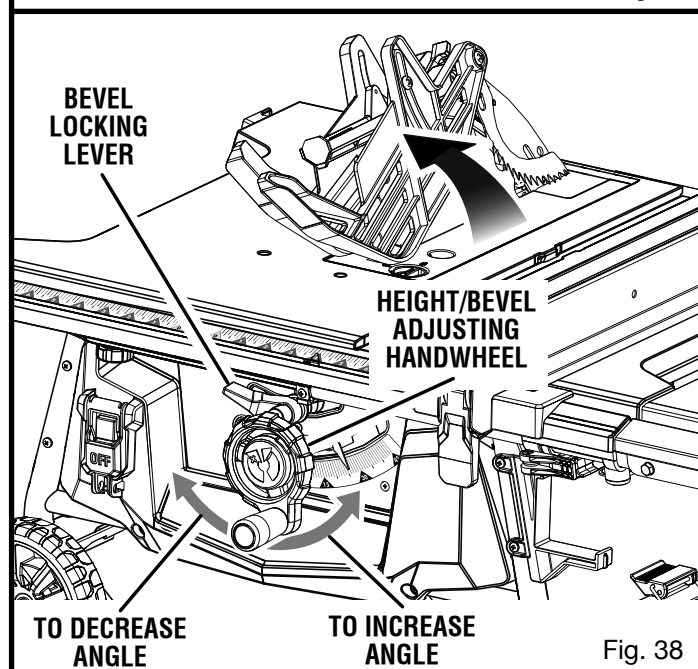

Fig. 38

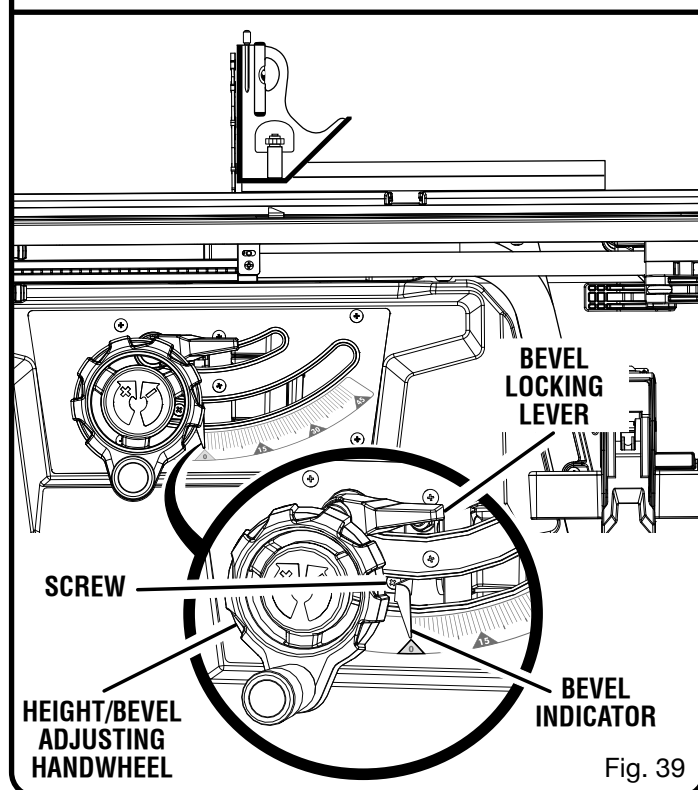

Fig. 39

# OPERATION

## TO USE THE RIP FENCE

See Figure 40 - 41.

### **WARNING:**

To reduce the risk of injury, always make sure the rip fence is parallel to the blade before beginning any operation.

**NOTE:** The rip fence included with your saw has a low fence. The low fence should face away from the blade when cutting material greater than 3/4 inches thick. The low fence should face toward the blade when cutting thin and/or narrow workpieces. **NEVER** support the weight of the workpiece on the low fence while making a cut.

- Loosen the rip fence by lifting the locking lever.
- Place the rear lip on the rear of the saw table and pull slightly toward the front of the unit.
- Lower the front end of the rip fence onto the guide surfaces on top of the front rail.
- Check for smooth gliding action.
- Position the rip fence the desired distance from the blade.
- With the rip fence flat on the saw table, push the fence towards the front rail to align the fence to the blade.
- Push the locking lever down to align and secure the fence. When securely locked, the locking lever should point downward.

**NOTE:** Ensure the locking lever secures the rip fence in place. If adjustments are needed, see **To Check the Tightness of the Rip Fence Locking Lever** in the *Adjustment* section of this manual.

**NOTE:** If the rip fence is not parallel to the blade, adjustments are needed. Refer to: **To Check the Alignment of the Rip Fence to the Blade** in the *Adjustment* section of this manual.

## TO SET THE RIP FENCE SCALE INDICATOR TO THE BLADE

See Figure 42.

Use the indicator on the rip fence to position the fence along the scale on the front rail.

**NOTE:** The blade guard must be removed to perform this adjustment. Reinstall the blade guard when the adjustment is complete.

Begin with the blade at a zero angle (straight up).

- Unplug the saw.
- Loosen the rip fence by lifting the locking lever.
- Using a framing square, set the rip fence 2 in. from the blade tip edge.
- Loosen the screw on the scale indicator and align with the 2 in. mark as shown.
- Tighten the screw and check the dimension and the rip fence.

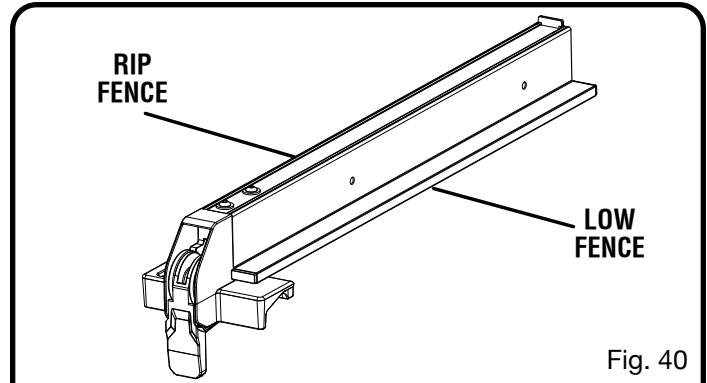

Fig. 40

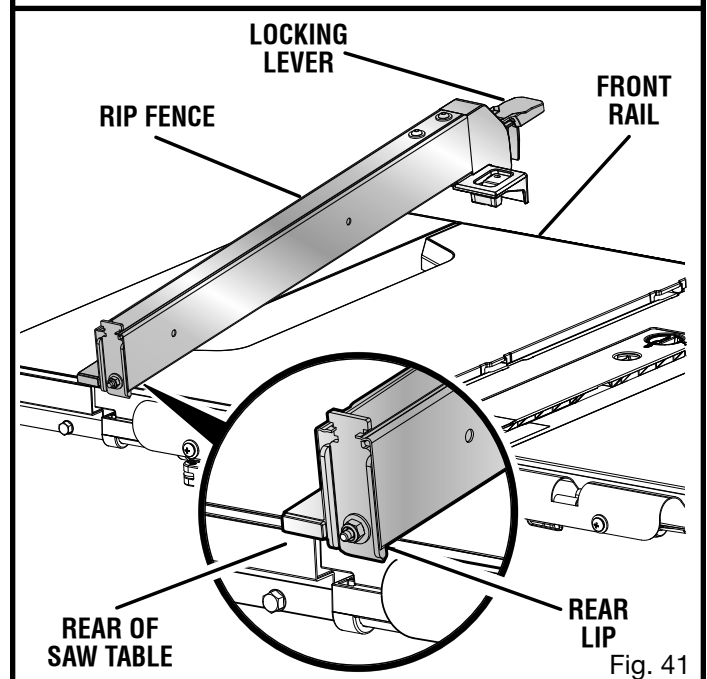

Fig. 41

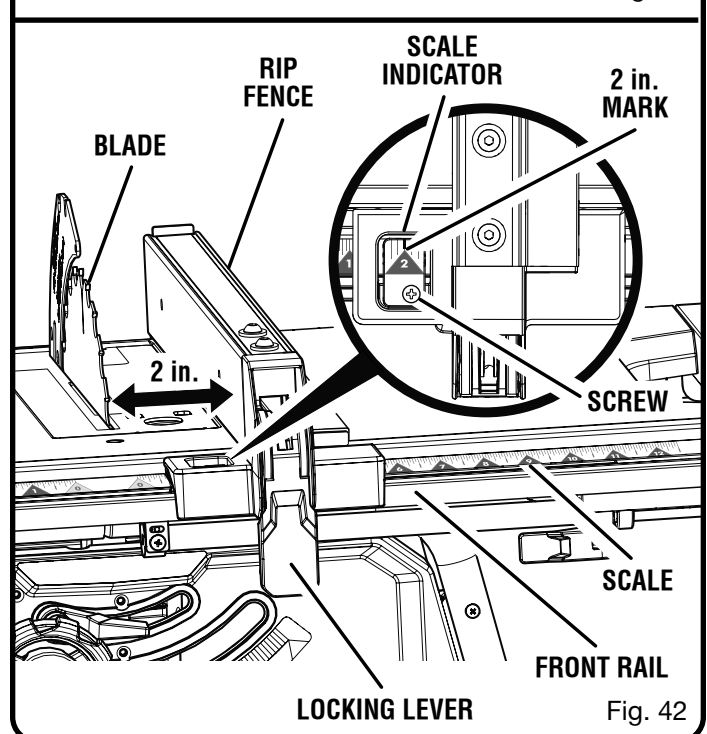

Fig. 42

# OPERATION

## TO USE THE SLIDING TABLE EXTENSION

See Figures 43 - 44.

Increase the length of the saw table by using the table extension.

- Set the rip fence to 14 in.

### **⚠ WARNING:**

The rip fence must be locked in the 14 in. position to ensure the accuracy of the secondary scale measurement and to provide proper support of the workpiece when using the table in the extended position. Failure to position the rip fence correctly will cause inaccurate workpiece measurements and could result in serious personal injury.

- Pull the front table locking lever toward you to unlock the lever. Repeat with the back lever.
- Slide the table extension to the desired width.

**NOTE:** Use the scale on the front rail when a specific width is desired.

- Once the table extension are set to the desired width, relock the front and back locking levers by pushing the levers back towards the saw base.

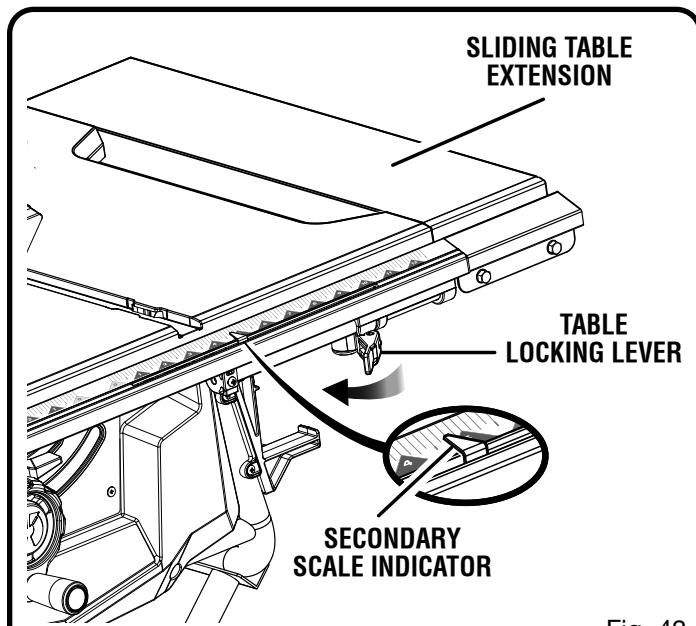

Fig. 43

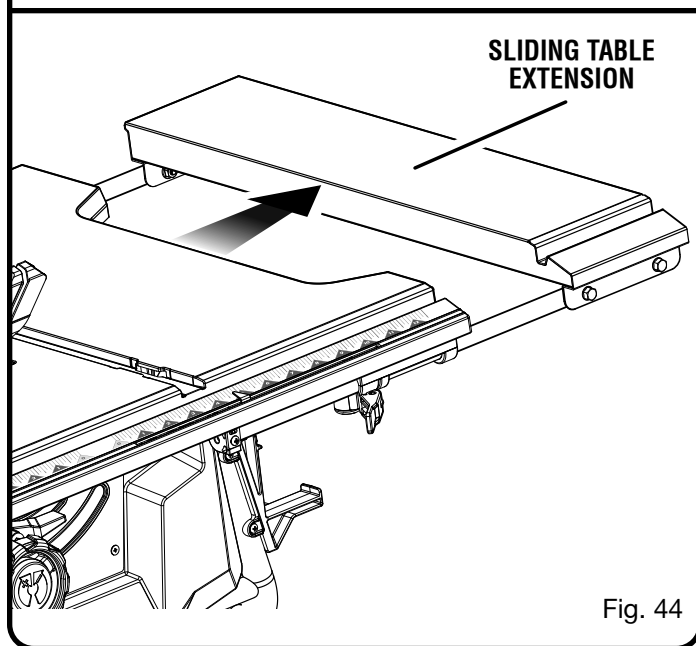

Fig. 44



# OPERATION

## TO USE THE MITER GAUGE

See Figure 45.

The miter gauge provides greater accuracy in angled cuts. For very close tolerances, test cuts are recommended.

The miter gauge can be turned 60° to the right or left.

- Loosen the lock knob.
- With the miter gauge in the miter gauge groove, rotate the gauge until the desired angle is reached on the scale.
- Retighten the lock knob.

## ADJUSTING THE BLADE PARALLEL TO THE MITER GAUGE GROOVE (REMOVING HEEL)

See Figures 46 - 48.

### WARNING:

The blade must be made parallel to the miter gauge groove so the wood does not bind resulting in kickback. Failure to do so could result in serious personal injury.

Do not loosen any bolts for this adjustment until you have checked with a square and made test cuts to be sure adjustments are necessary. Once the bolts are loosened, these items must be reset.

- Unplug the saw.
- Remove the blade guard and riving knife. Raise the blade by turning the height/bevel adjusting handwheel clockwise.

**NOTE:** For details on removing and reinstalling the riving knife, see **Cleaning the Riving Knife Lock Lever Plates** in the *Maintenance* section of this manual.

- Mark beside one of the blade teeth at the front of the blade. Using a ruler, measure the distance from the inside face of the blade tooth to the left edge of the miter gauge groove.

**NOTE:** For greater accuracy, place the marked blade tooth on top of the ruler.

- Turn the blade so the marked tooth is at the back.
- Move the ruler to the rear and again measure the distance from the inside face of the blade tooth to the left edge of the miter gauge groove. If the distances are the same, the blade and the miter gauge groove are parallel.
- Replace blade guard and riving knife.

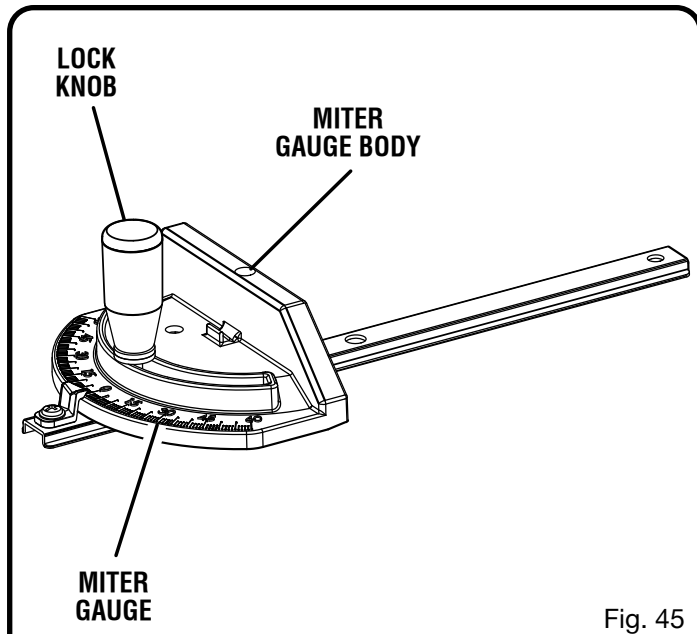

Fig. 45

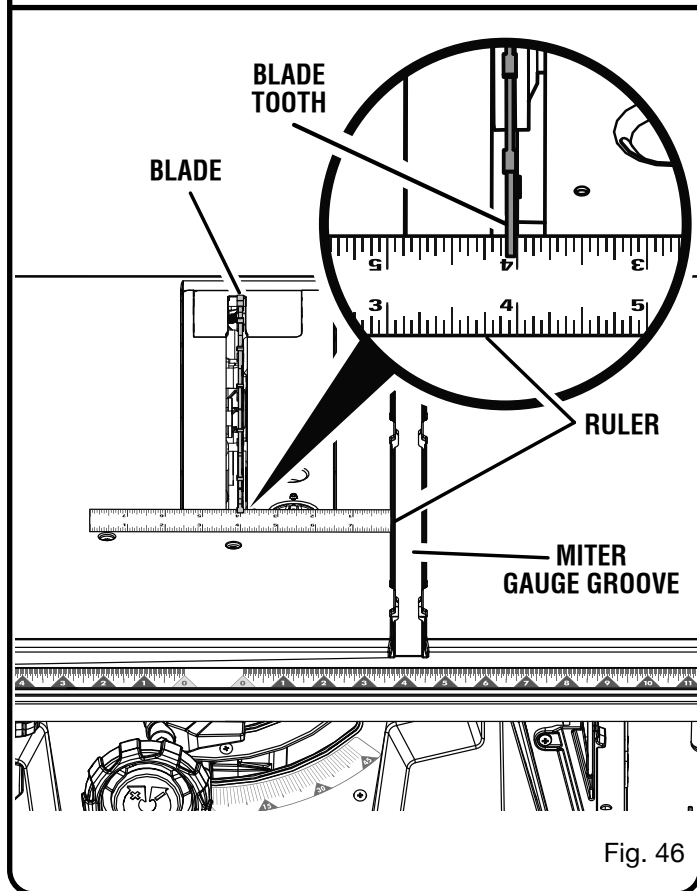

Fig. 46

# OPERATION

## If the distances are different:

- Remove the blade guard and riving knife. Raise the blade by turning the height/bevel adjusting handwheel clockwise.
- Loosen the locking bolts by turning towards the left.  
**NOTE:** The bolts are located above the height/bevel adjusting handwheel and under the saw table in the front of the saw.
- Turn adjusting bolt left or right until the blade is square.
- Tighten the locking bolts. Check again for squareness and continue to adjust if needed.

### **WARNING:**

To reduce the risk of injury from kickback, align the rip fence to the blade following any blade adjustments. Always make sure the rip fence is parallel to the blade before beginning any operation.

## MAKING CUTS

### **WARNING:**

Before making any cuts, make sure that the table saw stand is on a firm level surface where there is plenty of room to handle and properly support the table saw and the workpiece. If a suitable location can not be found, then the saw should not be used. Operating the saw in a location that does not provide adequate space and stable footing for the table saw stand could create a tipping hazard which could result in serious personal injury.

This table saw can perform a variety of cuts that are not all mentioned in this manual. DO NOT attempt to make any cuts not covered here unless you are thoroughly familiar with the proper procedures and necessary accessories. Your local library has many books on table saw usage and specialized woodworking procedures for your reference.

The blade provided with the saw is a high-quality combination blade suitable for ripping and cross cut operations. Carefully check all setups and rotate the blade one full revolution to assure proper clearance before connecting saw to power source. Stand slightly to the side of the blade path to reduce the chance of injury should kickback occur.

### **WARNING:**

Do not use blades rated less than the speed of this tool. Failure to heed this warning could result in personal injury.

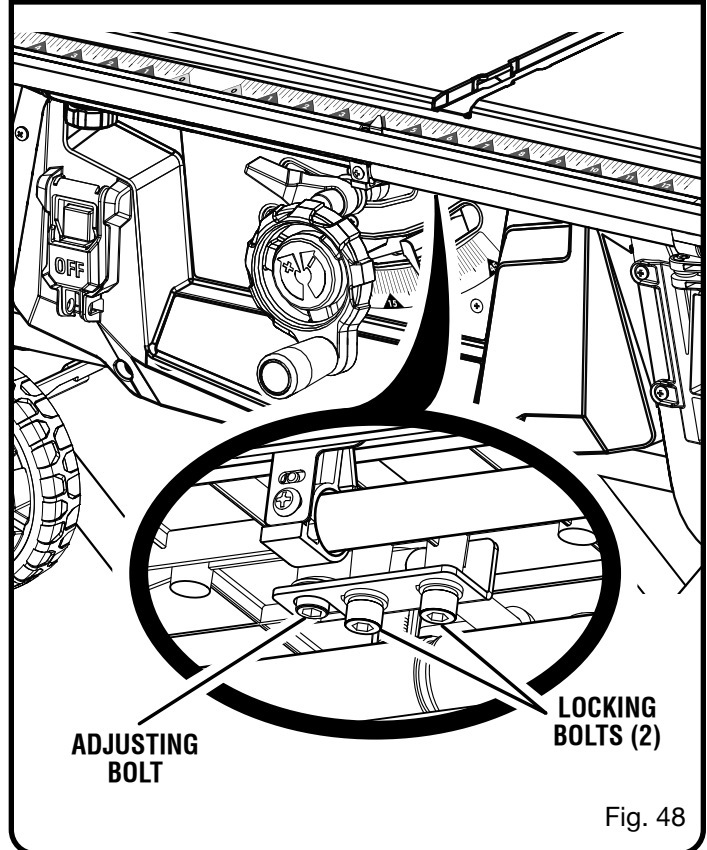
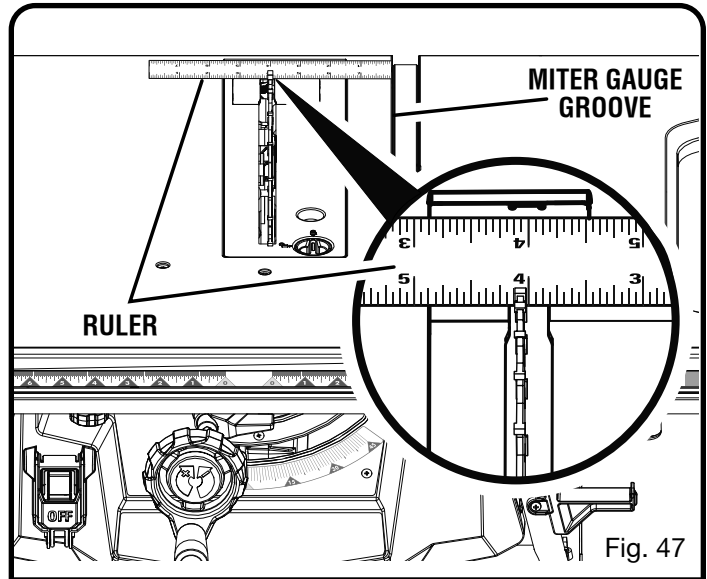

Use the miter gauge when making cross, miter, bevel, and compound miter cuts. To secure the angle, lock the miter gauge in place by twisting the lock knob clockwise. Always tighten the lock knob securely in place before use.

During use the miter gauge may move slightly left or right inside the miter gauge groove. For greater accuracy, press the miter gauge against the left or right edge of the miter gauge groove when making cuts. Do not allow the gauge to go from one side to the other.

# OPERATION

Always place the workpiece against the face of the miter gauge body when making cuts. To prevent the workpiece from moving, you can attach a piece of sandpaper to the miter gauge body face.

**NOTE:** It is recommended that you place the piece to be saved on the same side of the blade as the miter gauge, and that you make a test cut on scrap wood first.

## MAKING A CROSS CUT

See Figures 49 - 51.

### WARNING:

Make sure the blade guard assembly is installed and working properly to avoid serious possible injury.

### WARNING:

Using the rip fence as a cutoff gauge when cross cutting will result in kickback which can cause serious personal injury.

- Remove the rip fence.
- Set the blade to the correct depth for the workpiece.
- Set the miter gauge to 0° and tighten the lock knob.
- Make sure the wood is clear of the blade before turning on the saw.
- Press the top button on the switch to turn the saw on.  
**NOTE:** The switch cover does not have to be raised to operate the switch.
- Press the bottom button on the switch to turn the saw off.  
**NOTE:** To prevent unauthorized use, install a padlock (not included) through the holes in the switch and cover as shown in figure 50.
- Let the blade build up to full speed before moving the workpiece into the blade.
- Hold the workpiece firmly with both hands on the miter gauge and feed the workpiece into the blade.  
**NOTE:** The hand closest to the blade should be placed on the miter gauge lock knob and the hand farthest from the blade should be placed on the workpiece.
- When the cut is made, turn the saw off. Wait for the blade to come to a complete stop before removing the workpiece.

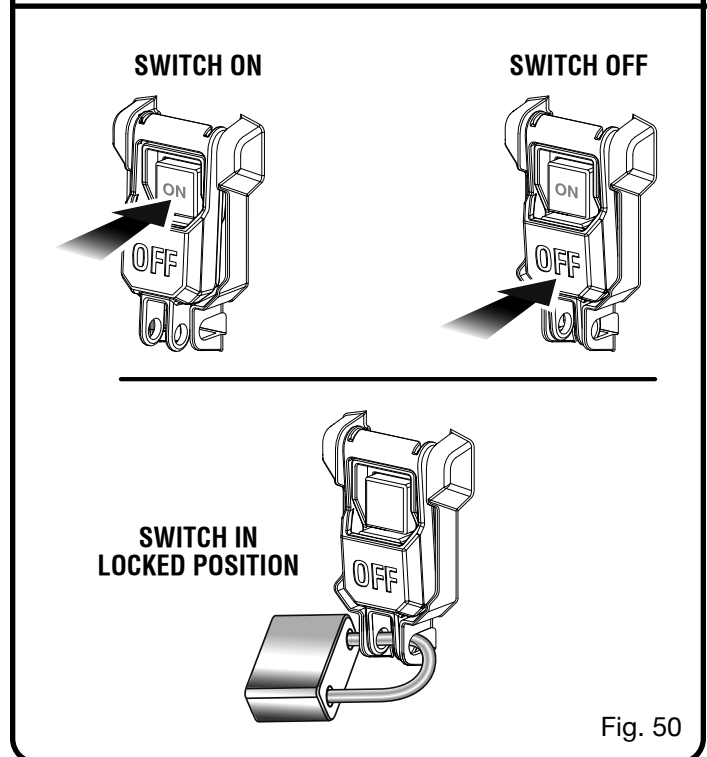
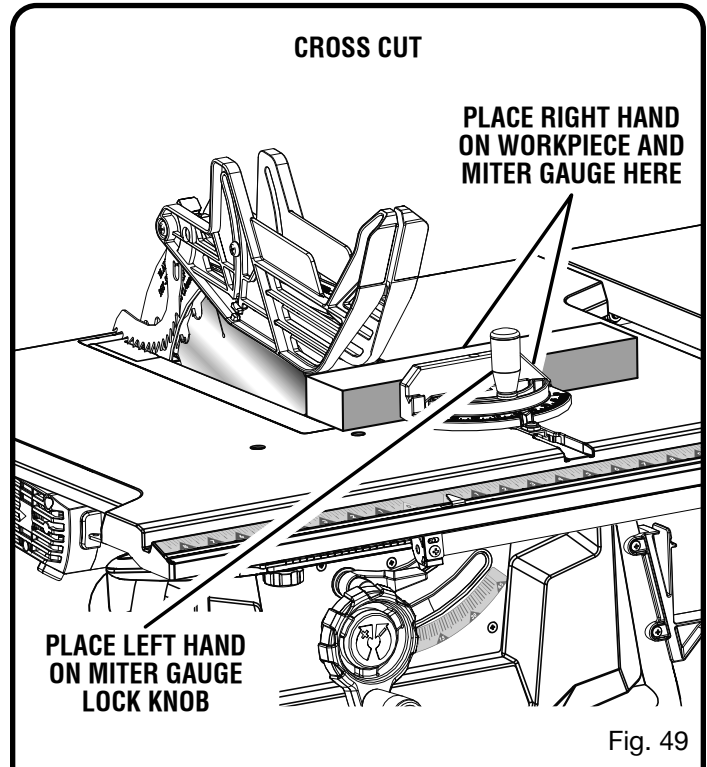

# OPERATION

## To make repetitive cross cuts:

A stop block can be used as a cut-off gauge to make repetitive cross cuts of the same length without having to mark the workpiece for each cut. The end of a stop block should always be in front of the blade. NEVER use the rip fence as a cut-off gauge.

- Remove the rip fence.
- Set the blade to the correct depth for the workpiece.
- Set the miter gauge to 0° and tighten the lock knob.
- Position a 3 in. block of wood at the desired distance from the blade to act as a cut-off gauge.
- Secure the stop block in place using a vice or a clamp.

### WARNING:

When secured, the end of the stop block should be in front of the blade. Securing the stop block beyond the front of the blade will result in kickback which can cause serious personal injury.

- Position the workpiece on the miter gauge with the edge flush against the stop block.
- When cutting a long or wide workpiece, place a support the same height as the table surface in front of the saw, behind the saw, and on the sides of the saw as needed.
- Turn the saw on.
- Hold the workpiece firmly with both hands on the miter gauge and feed the workpiece into the blade.

**NOTE:** The hand closest to the blade should be placed on the miter gauge lock knob and the hand farthest from the blade should be placed on the workpiece.

- When the cut is made, turn the saw off. Wait for the blade to come to a complete stop before removing the cut piece.
- Move the miter gauge back to the front of the saw and position the workpiece for the next cut.
- After the last cut, turn the saw off. Wait for the blade to come to a complete stop and remove the stop block.

## MAKING A RIP CUT

See Figure 52 - 53.

### WARNING:

Make sure the blade guard assembly is installed and working properly to avoid serious possible injury.

### WARNING:

Taper cuts must only be made with a special jig, which is commercially available. Do not attempt a free hand taper cut on this saw. Failure to follow these instructions could result in serious personal injury.

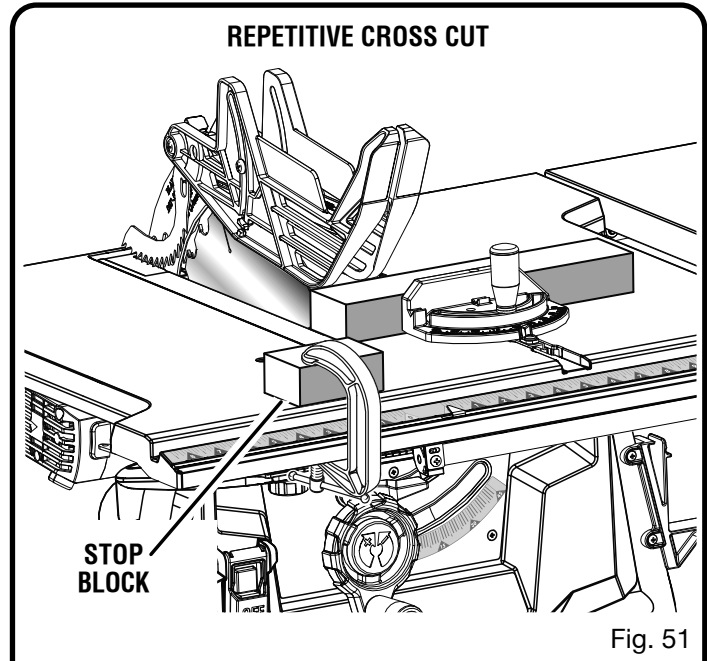

Fig. 51

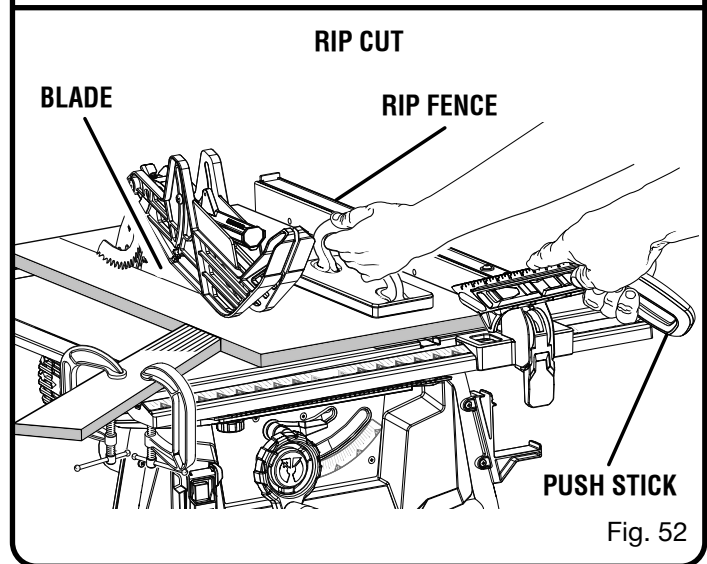

Fig. 52

- Set the blade to the correct depth for the workpiece.
- Position the rip fence the desired distance from the blade for the cut and securely lock the handle.

**NOTE:** Do not place the rip fence on the left side of the blade when cutting material greater than 3/4 inches thick. Workpieces thicker than 3/4 inches may be unstable and require additional hold downs to ensure stability during cutting.

- When cutting a long or wide workpiece, place a support the same height as the table surface in front of the saw, behind the saw, and on the sides of the saw as needed.
- Install featherboard in the appropriate position for the cut being made.
- Make sure the workpiece is clear of the blade before turning on the saw.

# OPERATION

- Turn the saw on.
- Position the workpiece flat on the table with the edge flush against the rip fence. Let the blade build up to full speed before feeding the workpiece into the blade.
- Using a push stick and/or push blocks, slowly feed the workpiece toward the blade. Stand slightly to the side of the workpiece as it contacts the blade to reduce the chance of injury should kickback occur.
- Once the blade has made contact with the workpiece, use the hand closest to the rip fence to guide it. Make sure the edge of the workpiece remains in solid contact with both the rip fence and the surface of the table. If ripping a narrow piece, use a push stick, push blocks and/or a narrow ripping jig to move the piece through the cut and past the blade.
- When the cut is made, turn the saw off. Wait for the blade to come to a complete stop before removing the workpiece.

## To make rip cuts narrower than 2 inches:

If a narrow ripping jig is not used, the rip fence included with your saw has a low fence to allow narrow ripping operations.

### **WARNING:**

When making narrow rip cuts always ensure that the piece being cut cannot fall into the throat plate of the saw. If this piece falls into the throat plate it may damage the under table guarding and create a hazardous condition to the operator.

- Unlock the rip fence and place it on the left side of the blade.  
**NOTE:** The rip fence included with your saw has a low fence. The low fence should face away from the blade when cutting material greater than 3/4 inches thick. The low fence should face toward the blade when cutting thin and/or narrow workpieces.
- Lift the blade guard's left side barrier and lower it onto either the workpiece or the narrow rip fence to ensure coverage of the cutting zone during this operation.
- Secure the rip fence.
- Position the workpiece flat on the table with the edge flush against the low fence.

- Using a push block and/or push stick make the rip cut, see **Making a Rip Cut** earlier in this section.

**NOTE:** This technique is for making narrow rip cuts on workpieces with a thickness of 3/4 inches or less. To make narrow rip cuts on thicker material use a narrow ripping jig, refer to **How To Make A Jig (For Rip Cutting Narrow Workpiece)** earlier in this section.

**NOTE:** The cutting operation described above and illustrated in figure 53 will result in the saved piece being between the rip fence and the left side of the blade. Alternatively, you could place the rip fence and the wide portion of the workpiece on the left side of the blade, which would result in the saved piece being on the right.

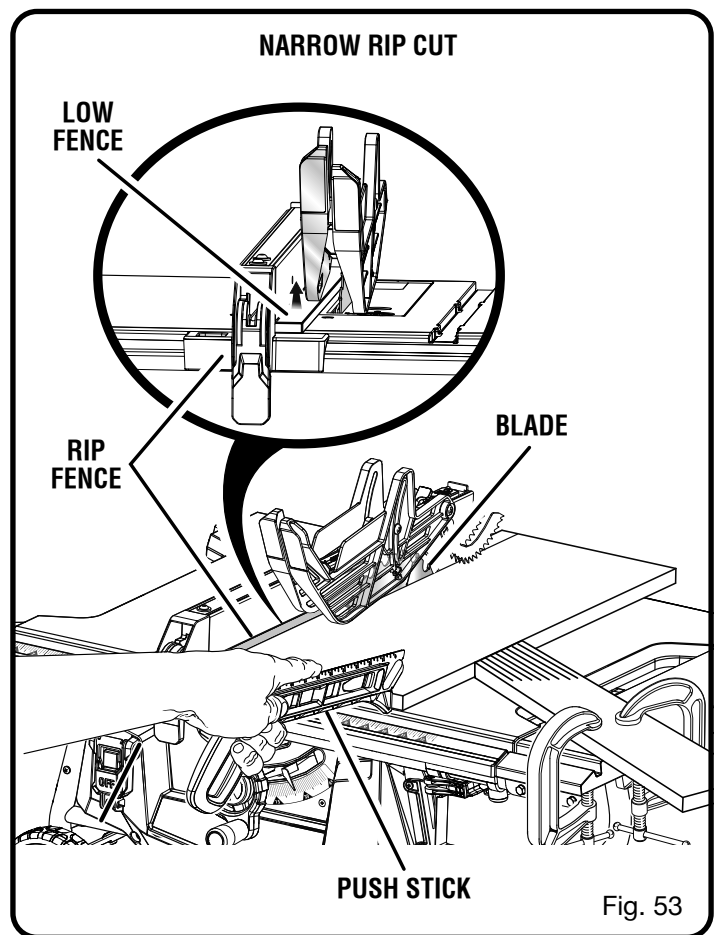

Fig. 53

# OPERATION

## MAKING A MITER CUT

See Figure 54.

### WARNING:

Make sure the blade guard assembly is installed and working properly to avoid possible serious injury.

- Remove the rip fence.
- Set the blade to the correct depth for the workpiece.
- Set the miter gauge to the desired angle and tighten the lock knob.
- Make sure the workpiece is clear of the blade before turning on the saw.
- Turn the saw on.
- Let the blade build up to full speed before moving the workpiece into the blade.
- Hold the workpiece firmly with both hands on the miter gauge and feed the workpiece into the blade.  
**NOTE:** The hand closest to the blade should be placed on the miter gauge lock knob and the hand farthest from the blade should be placed on the workpiece.
- When the cut is made, turn the saw off. Wait for the blade to come to a complete stop before removing the workpiece.

## MAKING A BEVEL CROSS CUT

See Figures 55 - 56.

### WARNING:

Make sure the blade guard assembly is installed and working properly to avoid possible serious injury.

- Remove the rip fence.
- Unlock the bevel locking lever.
- Adjust the bevel angle to the desired setting.
- Lock the bevel locking lever.
- Set the blade to the correct depth for the workpiece.
- Set the miter gauge to 0° and tighten the lock knob.
- Make sure the workpiece is clear of the blade before turning on the saw.
- Turn the saw on.
- Let the blade build up to full speed before moving the workpiece into the blade.
- Hold the workpiece firmly with both hands on the miter gauge and feed the workpiece into the blade.  
**NOTE:** The hand closest to the blade should be placed on the miter gauge lock knob and the hand farthest from the blade should be placed on the workpiece.
- When the cut is made, turn the saw off. Wait for the blade to come to a complete stop before removing the workpiece.

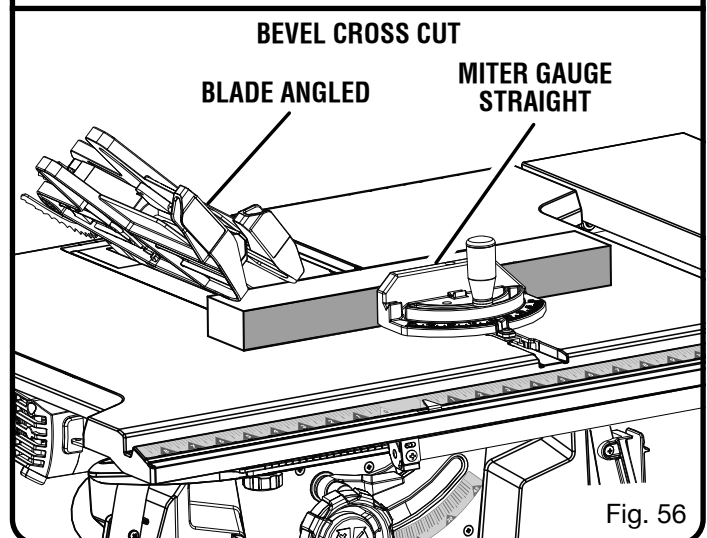
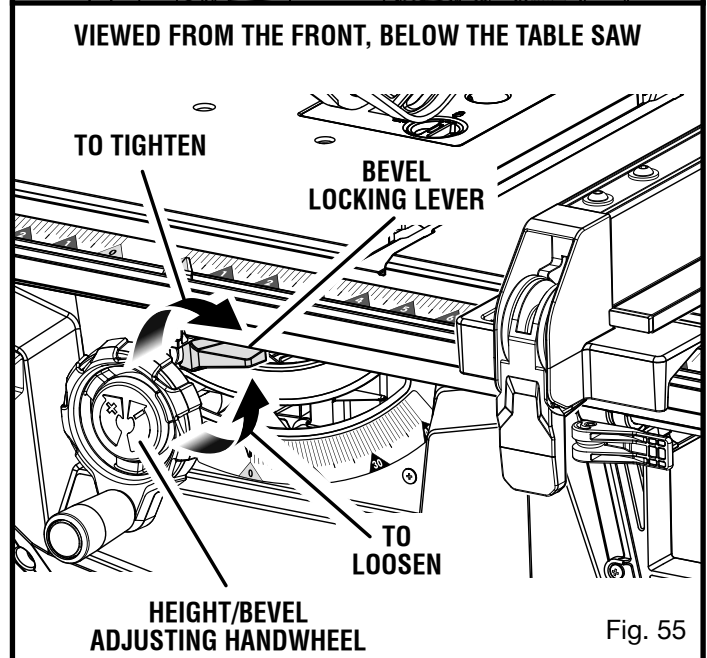
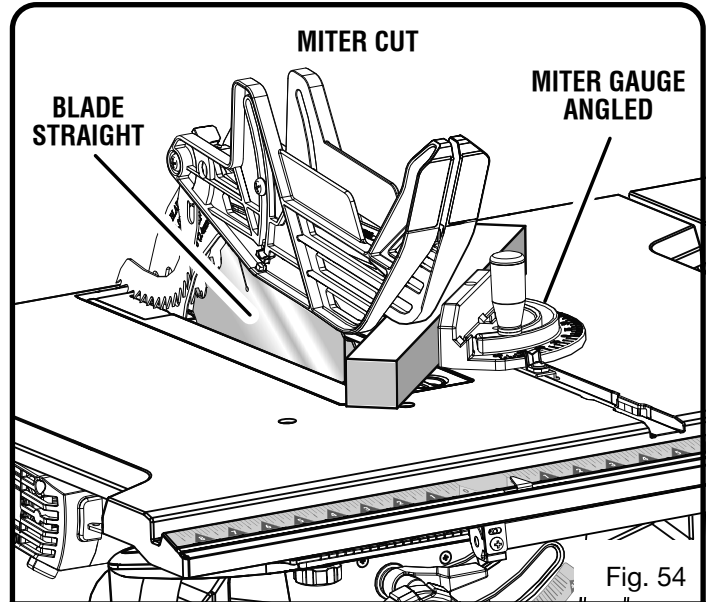

# OPERATION

## MAKING A BEVEL RIP CUT

See Figure 57.

### **WARNING:**

Make sure the blade guard assembly is installed and working properly to avoid serious personal injury.

### **WARNING:**

The rip fence must be on the right side of the blade to avoid trapping the wood and causing kickback. Placement of the rip fence to the left of the blade will result in kickback and the risk of serious personal injury.

- Remove the miter gauge.
- Install featherboard in the appropriate position for the cut being made.
- Unlock the bevel locking lever.
- Adjust the bevel angle to the desired setting.
- Lock the bevel locking lever.
- Set the blade to the correct depth for the workpiece.
- Position the rip fence the desired distance from the blade for the cut and securely lock the handle.
- Make sure the wood is clear of the blade before turning on the saw.
- When cutting a long or wide workpiece, place a support the same height as the table surface in front of the saw, behind the saw, and on the sides of the saw as needed.
- Turn the saw on.
- Position the workpiece flat on the table with the edge flush against the rip fence. Let the blade build up to full speed before feeding the workpiece into the blade.

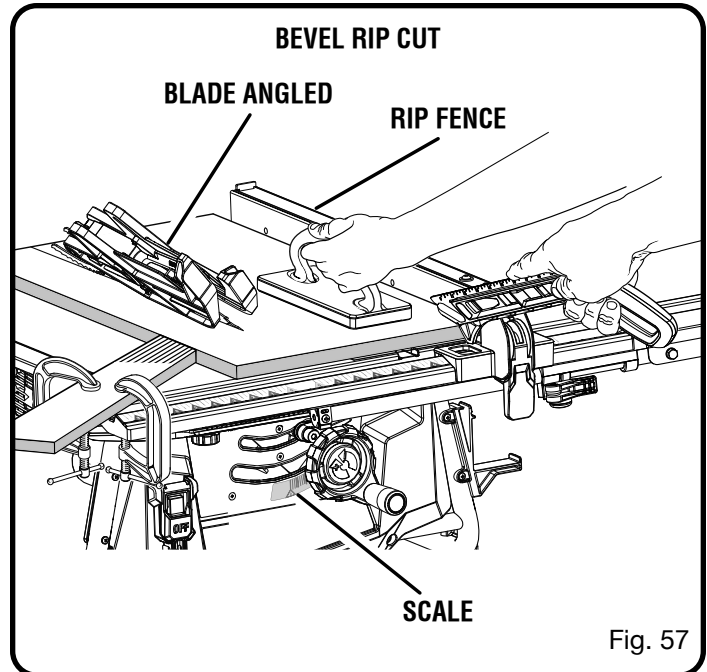

Fig. 57

- Using a push stick and/or push blocks, slowly feed the workpiece toward the blade. Stand slightly to the side of the wood as it contacts the blade to reduce the chance of injury should kickback occur.
- Once the blade has made contact with the workpiece, use the hand closest to the rip fence to guide it. Make sure the edge of the workpiece remains in solid contact with both the rip fence and the surface of the table. If ripping a narrow piece, use a push stick and/or push blocks to move the piece through the cut and past the blade.
- When the cut is made, turn the saw off. Wait for the blade to come to a complete stop before removing the workpiece.

# OPERATION

## MAKING A COMPOUND (BEVEL) MITER CUT

See Figure 58.

### **⚠ WARNING:**

Make sure the blade guard assembly is installed and working properly to avoid possible serious injury.

- Remove the rip fence.
- Unlock the bevel locking lever.
- Adjust the bevel angle to the desired setting.
- Lock the bevel locking lever.
- Set the blade to the correct depth for the workpiece.
- Set the miter gauge to the desired angle and tighten the lock knob.
- Make sure the wood is clear of the blade before turning on the saw.
- Turn the saw on.
- Let the blade build up to full speed before moving the workpiece into the blade.
- Hold the workpiece firmly with both hands on the miter gauge and feed the workpiece into the blade.

**NOTE:** The hand closest to the blade should be placed on the miter gauge lock knob and the hand farthest from the blade should be placed on the workpiece.

- When the cut is made, turn the saw off. Wait for the blade to come to a complete stop before removing the workpiece.

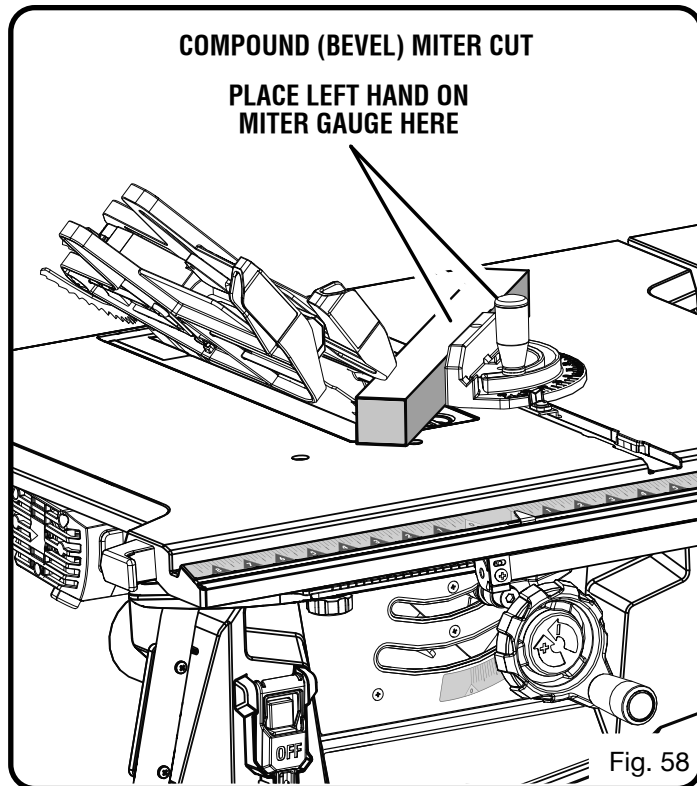



# OPERATION

## MAKING A LARGE PANEL CUT

See Figure 59.

Make sure the saw is properly secured to a work surface to avoid tipping from the weight of a large panel.

### **WARNING:**

Make sure the blade guard assembly is installed and working properly to avoid possible serious injury.

### **WARNING:**

Never make freehand cuts (cuts without the miter gauge or rip fence). Unguided workpieces can result in serious injury.

- Install featherboard in the appropriate position for the cut being made.
- When cutting a long or wide workpiece, place a support the same height as the table surface in front of the saw, behind the saw, and on the sides of the saw as needed.

### **WARNING:**

Improper support of the workpiece on the side and/or outfeed side of the saw could create unexpected movement of the workpiece and/or the saw, resulting in serious personal injury.

- Depending on the shape of the panel, use the rip fence or miter gauge. If the panel is too large to use either the rip fence or the miter gauge, it is too large for this saw.
- Make sure the workpiece does not touch the blade before you turn on the saw.
- Turn the saw on.
- Position the workpiece flat on the table with the edge flush against the rip fence. Let the blade build up to full speed before feeding the workpiece into the blade.

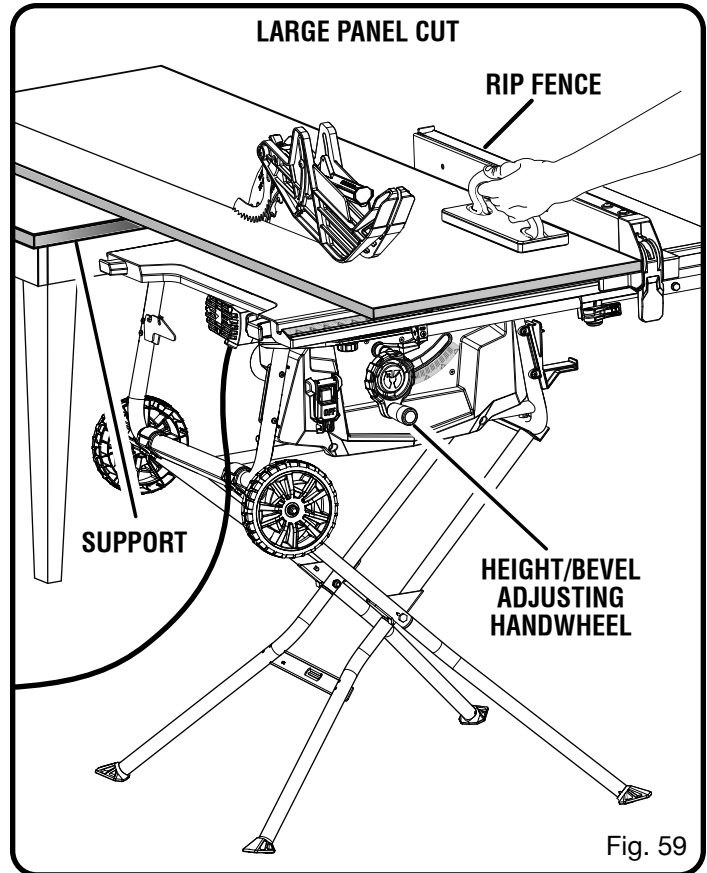

Fig. 59

- Using a push stick and/or push blocks, slowly feed the workpiece toward the blade. Stand slightly to the side of the wood as it contacts the blade to reduce the chance of injury should kickback occur.
- Once the blade has made contact with the workpiece, use the hand closest to the rip fence to guide it. Make sure the edge of the workpiece remains in solid contact with both the rip fence and the surface of the table. If ripping a narrow piece, use a push stick and/or push blocks to move the piece through the cut and past the blade.
- When the cut is made, turn the saw off. Wait for the blade to come to a complete stop before removing the workpiece.

# OPERATION

## MAKING A NON-THROUGH CUT

See Figure 60.

Non-through cuts (made with a standard 10 in. blade) can be made with the grain (ripping) or across the grain (cross cut). The use of a non-through cut is essential to cutting grooves, rabbets, and dadoes. This is the only type cut that is made without the blade guard assembly installed. Make sure the blade guard assembly is reinstalled upon completion of this type of cut. Read the appropriate section which describes the type of cut in addition to this section on non-through or dado cuts. For example, if your non-through cut is a straight cross cut, read and understand the section on straight cross cuts before proceeding.

### **⚠ WARNING:**

When making a non-through cut, the blade is covered by the workpiece during most of the cut. Be alert to the exposed blade at the start and finish of every cut to reduce the risk of personal injury.

### **⚠ WARNING:**

Never feed wood with your hands when making any non-through cut such as rabbets or dadoes. To avoid personal injury, always use push blocks, push sticks, and featherboards.

- Unplug the saw.
- Remove the blade guard.
- Place riving knife in “down” position.
- Unlock the bevel locking lever.
- Adjust the bevel angle to 0°.
- Lock the bevel locking lever.
- Set the blade to the correct depth for the workpiece.
- Depending on the shape and size of the wood, use either the rip fence or miter gauge.
- Plug the saw into the power source and turn the saw on.

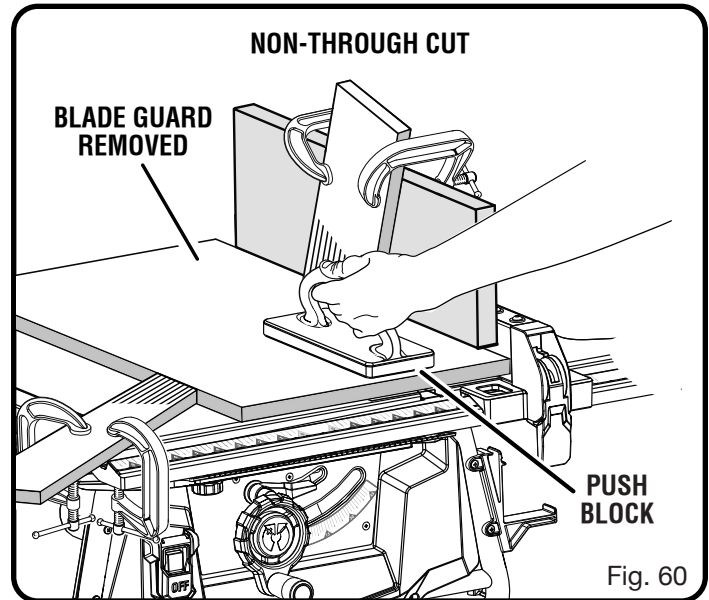

Fig. 60

- Let the blade build up to full speed before moving the workpiece into the blade.
- Always use push blocks, push sticks, and/or featherboards appropriately when making non-through cuts to reduce the risk of serious injury.
- When the cut is made, turn the saw off. Wait for the blade to come to a complete stop before removing the workpiece.

**NOTE:** A non-through rip cut is shown in the illustration above. To make a non-through cross cut, remove the blade guard and anti-kickback pawls. Place the riving knife in the “down” position and perform the cross cut, see **Making a Cross Cut** earlier in this section.

### **Once all non-through cuts are completed:**

- Unplug the saw.
- Place riving knife in “up” position.
- Reinstall blade guard.

# OPERATION

## MAKING A DADO CUT

See Figure 61.

An optional dado throat plate is required for this procedure (see the *Accessories* section of this manual and check with the retailer where the table saw was purchased). All blades and dado sets must not be rated less than the speed of this tool. This saw is designed for use with a 6 in. stack dado (up to width of 1/2 in.). Do not use an adjustable dado or molding cutters on this saw.

Rabbeting cuts are dado cuts made on the end of a workpiece. For best results, complete rabbet cuts using a dado stack blade.

**NOTE:** Use an auxiliary fence when making rabbet cuts to prevent the face of the rip fence from making contact with the dado blade stack during the cutting operation.

### **WARNING:**

When making a non-through cut, the blade is covered by the workpiece during most of the cut. Be alert to the exposed blade at the start and finish of every cut to reduce the risk of personal injury.

### **WARNING:**

Always put all blade washers in proper location when reinstalling standard blade. Failure to do so can result in possible injury and damage to the tool.

### **WARNING:**

Always use push blocks, push sticks, and/or featherboards when making dado cuts to avoid the risk of serious injury.

- Unplug the saw.
- Remove the blade guard, throat plate, and riving knife.  
**NOTE:** For details on removing and reinstalling the riving knife, see **Cleaning the Riving Knife Lock Lever Plates** in the Maintenance section of this manual.
- Remove the blade nut, blade washer, and saw blade.  
**NOTE:** Always store the blade washer and throat plate in a secure location.
- Mount the dado blade, according to manufacturer instructions, using the blade and chippers appropriate for the desired width of cut.
- Reinstall and securely tighten the blade nut.  
**NOTE:** The blade washer may be used provided the arbor shaft extends slightly beyond the arbor nut.
- Make sure the blade nut is fully engaged and the arbor extends past a securely tightened blade nut.

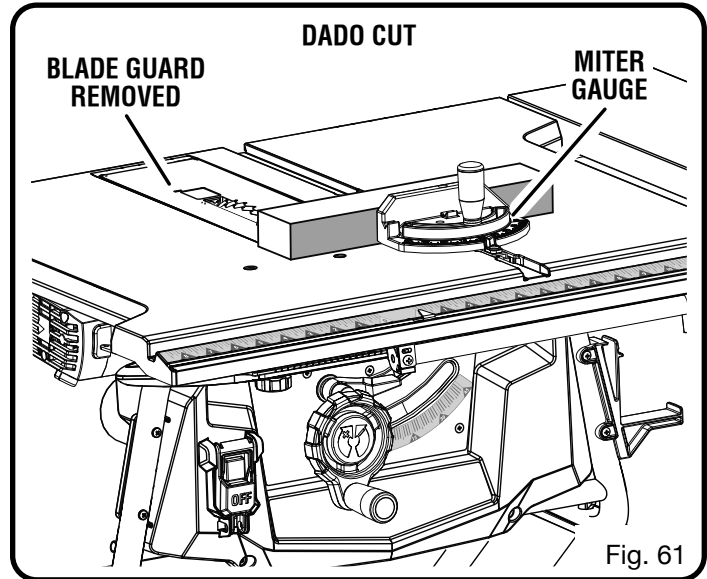

Fig. 61

- Place release lever in locked position.
- Install the dado throat plate and rotate the blade by hand to make sure it turns freely then lower the blade.
- Depending on the shape and size of the wood, use either the rip fence or miter gauge.
- If making a rip cut, install featherboard in the appropriate position for the cut being made.
- Turn the saw on.

**NOTE:** Make sure the wood does not touch the blade before you turn on the saw. Let the blade build up to full speed before feeding the workpiece into the blade.

- Position the workpiece flat on the table with the edge flush against the rip fence or miter gauge and hold firmly against the saw table.
- Use a push block or push stick to move the wood through the cut past the blade. Never push a small piece of wood into the blade with your hand, always use a push stick. The use of push blocks, push sticks, and featherboards are necessary when making non-through cuts.
- When the cut is made, turn the saw off. Wait for the blade to come to a complete stop before removing the workpiece.

**NOTE:** A dado cross cut is shown in the illustration above. To make a dado rip cut, remove the blade guard, anti-kickback pawls, throat plate, and riving knife. Install the dado blade and dado throat plate then perform the rip cut, see **Making a Rip Cut** earlier in this section.

### **Once all dado cuts are completed:**

- Unplug the saw.
- Remove the dado throat plate and dado blade.
- Reinstall the riving knife in the “up” position.
- Reinstall standard cutting blade, throat plate, and blade guard.

# ADJUSTMENTS

## **⚠ WARNING:**

Before performing any adjustment, make sure the tool is unplugged from the power supply and the top button on the switch is not depressed. Failure to heed this warning could result in serious personal injury.

To avoid unnecessary set-ups and adjustments, a good practice is to check your setups carefully with a framing square and make practice cuts in scrap wood before making finish cuts in good workpieces. Do not start any adjustments until you have checked with a square and made test cuts to be sure adjustments are needed.

## REPLACING THE BLADE

See Figures 62 - 64.

Wear gloves and other personal protective equipment when installing and removing a blade only. **DO NOT** wear gloves when operating the saw. **DO NOT** place gloved hand near blade when it is in motion.

Use correct blades. Blade kerf width and blade body thickness must be within the limits stamped on the riving knife.

- Unplug the saw.
- Remove the blade guard and anti-kickback pawls.
- Lower the saw blade and remove the throat plate.
- Lock the bevel locking lever.
- Raise the saw blade to full height.
- Insert the open end of the blade wrench onto the flats on the arbor shaft.
- Insert the closed end of the blade wrench over the blade nut. Holding both wrenches firmly, pull the outside wrench (right side) forward while pushing the inside (left side) to the back of the saw. Remove the blade nut and blade washer.

**NOTE:** Arbor shaft has right-hand threads.

- Unlock the release locking lever and remove the blade.
- To replace the blade with an accessory blade, follow the instructions provided with the accessory.

### To install a standard blade:

- Place the new blade on the arbor shaft (the teeth must point down toward the front of the saw to work properly).
- Place the blade washer and the blade nut over the arbor shaft. Be sure the flat side of the blade washer faces the blade and that all items are snug against the arbor housing. Make sure the blade nut is securely tightened. Do not overtighten.

**NOTE:** Arbor shaft has right-hand threads.

- Lock the release lever.
- Rotate the blade by hand to make sure it turns freely.
- Lower the saw blade and reinstall the throat plate.
- Check all clearances for free blade rotation.

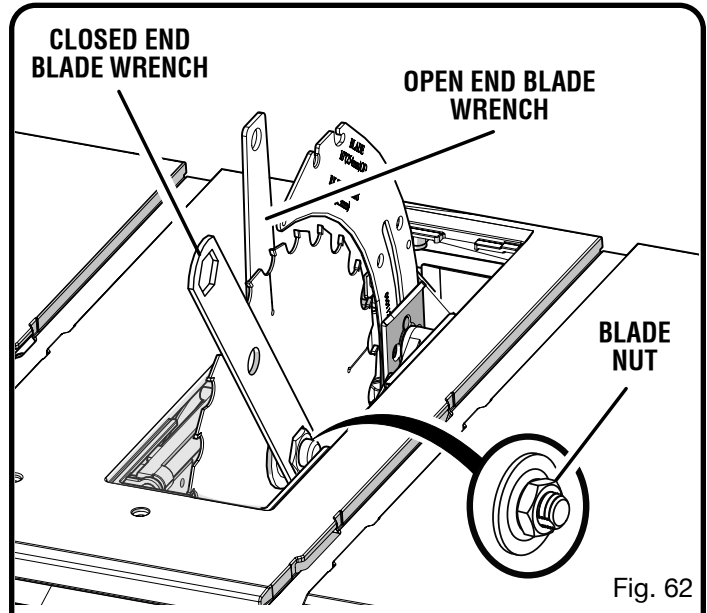

Fig. 62

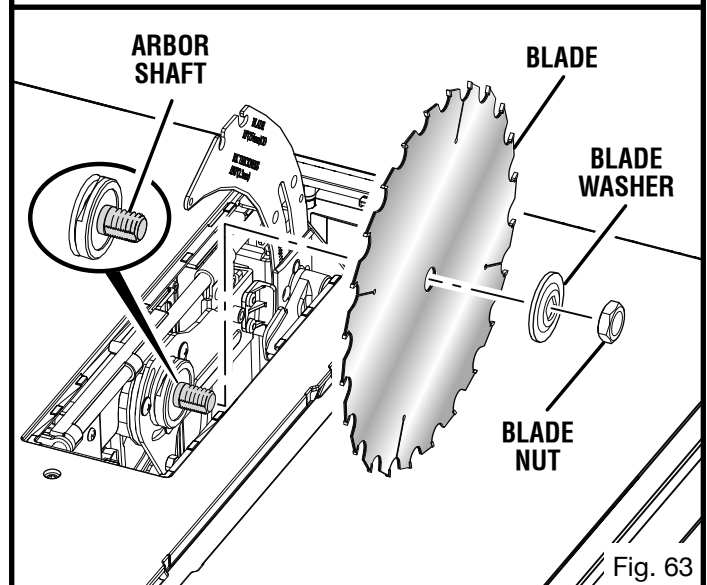

Fig. 63

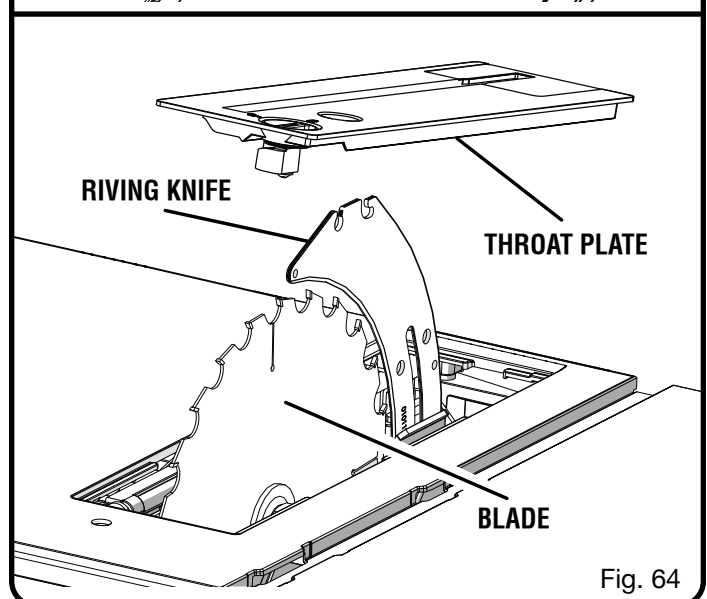

Fig. 64

# ADJUSTMENTS

After installation, adjust the rip scale indicator to account for the kerf and thickness of the blade. Refer to **To Set the Rip Fence Scale Indicator to the Blade** in the *Operation* section of this manual. In cutting operations, the scale will be set to the side of the blade where the cut will be measured and made.

## TO SET THE BEVEL INDICATOR AND BEVEL STOPS AT 0° AND 45°

See Figures 65 - 66.

The angle settings of the saw have been set at the factory and, unless damaged in shipping, should not require setting during assembly. After extensive use, they may need to be checked.

- Unplug the saw.
- Raise the blade.
- Remove the blade guard assembly.

### To check for squareness, 0° bevel:

- Unlock the bevel locking lever.
- Rotate the height/bevel adjusting handwheel until the blade is tilted to the right as far as it will go.
- Lock the bevel locking lever.
- Place the combination square against blade. Make sure square is not touching the tip of one of the saw teeth.

### If the blade is not an exact 90° (0° bevel):

- Unlock the bevel locking lever.
- Turn the height/bevel adjusting handwheel until the bevel indicator points to 5°-10°.
- Turn the 0° stop screw 1/4 turn in the clockwise or counterclockwise direction.
- Rotate the height/bevel adjusting handwheel until the blade is tilted to the right as far as it will go.
- Lock the bevel locking lever and check the blade angle.
- Repeat above steps to readjust and recheck blade angle as needed.

### Once blade is square to the table (0° bevel):

- Check bevel indicator.
- If indicator is not pointing to the 0° mark on the bevel scale, loosen the indicator adjusting screw and adjust indicator.
- Retighten screw.

### To check for squareness, 45° bevel:

- Unlock the bevel locking lever.
- Rotate the height/bevel adjusting handwheel until the blade is tilted to the left as far as it will go.
- Lock the bevel locking lever.
- Place the combination square against blade. Make sure square is not touching the tip of one of the saw teeth.

### If the blade is not an exact 45°:

- Unlock the bevel locking lever.
- Turn the height/bevel adjusting handwheel until the bevel indicator points to 35°-40°.

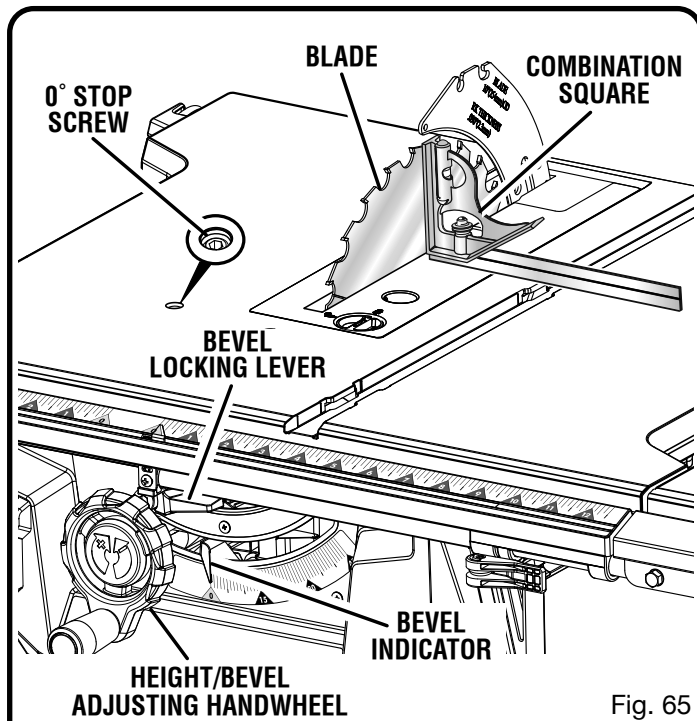

Fig. 65

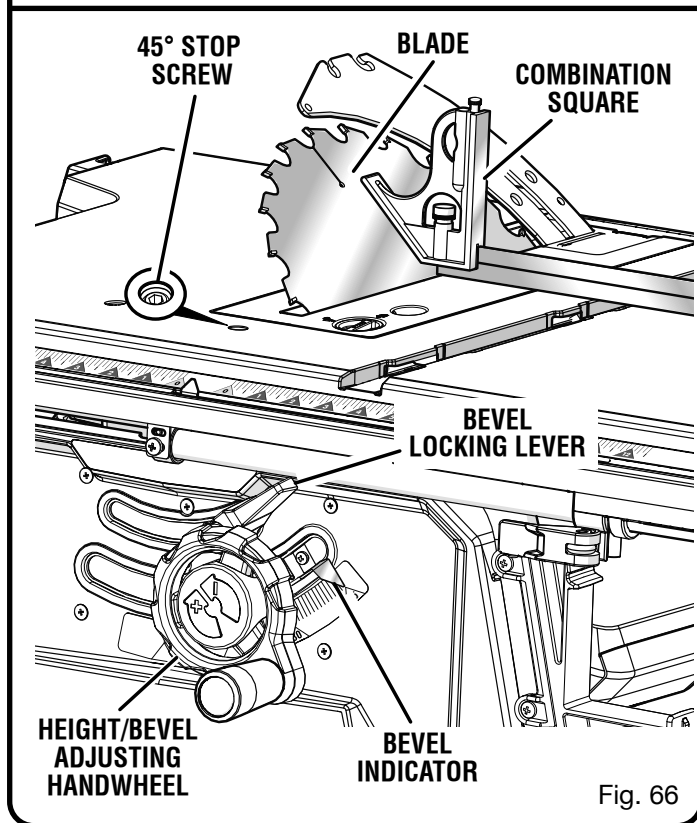

Fig. 66

- Turn the 45° stop screw 1/4 turn in the clockwise or counterclockwise direction.
- Rotate the height/bevel adjusting handwheel until the blade is tilted to the left as far as it will go.
- Lock the bevel locking lever and check the blade angle.
- Repeat above steps to readjust and recheck blade angle as needed.

# ADJUSTMENTS

## Once blade is 45° to the table:

- Check bevel indicator.
- If indicator is not pointing to the 45° mark on the bevel scale, loosen the indicator adjusting screw and adjust indicator.
- Retighten screws.

## When all adjustments are complete:

- Reinstall the blade guard assembly.

## TO CHECK THE ALIGNMENT OF THE RIP FENCE TO THE BLADE

See Figure 67.

The rip fence must be parallel to the saw blade and the miter gauge groove.

### **WARNING:**

A misaligned rip fence can cause kickbacks and jams. To reduce the risk of injury, always maintain proper rip fence alignment.

- Unplug the saw.
- Remove the blade guard, riving knife, and anti-kickback pawls. Raise the blade by turning the height/bevel adjusting handwheel clockwise.
- Verify the blade is parallel to the miter gauge groove as described in the **Adjusting the Blade Parallel to the Miter Gauge Groove (Removing Heel)** section in *Operation*.
- Move the rip fence near the saw blade (about three inches away) and lock the rip fence in place with the locking lever.
- Mark beside one of the blade teeth at the front of the blade. Using a ruler, measure the distance from the inside face of the blade tooth to the inside face of the rip fence.

**NOTE:** For greater accuracy, place the marked blade tooth on top of the ruler.

**NOTE:** If the rip fence is on the left side of the blade, measure from the low fence to the blade tooth.

- Turn the blade so the marked tooth is at the back.
- Move the ruler to the rear and again measure the distance from the inside face of the blade tooth to the inside face of the rip fence. If the distances are the same, the blade and the rip fence are parallel.

### If the distances are different:

- Unlock the rip fence.
- Loosen the two screws located on top of the rip fence.
- Adjust the rip fence.
- Alternately retighten the screws. Recheck alignment.
- Repeat steps as needed until rip fence is correctly aligned.
- Replace blade guard, riving knife, and anti-kickback pawls.

## TO CHECK THE TIGHTNESS OF THE RIP FENCE LOCKING LEVER

See Figure 68.

The locking lever on the rip fence should hold the rip fence securely against the front and back rails. The lever should not be difficult to push down and lock. To assure proper fence lock adjustment:

- Lock the rip fence in place.
- Try moving the fence from side-to-side. If the fence moves, tighten the lock nut 1/4 turn at a time, rechecking for movement after each adjustment.
- With the rip fence in the locked position, recheck rip fence parallelism with the blade and adjust if necessary.

**NOTE:** If it is difficult or too easy to lock and unlock the locking lever, adjust the lock nut until the lever is properly tensioned then repeat the above steps.

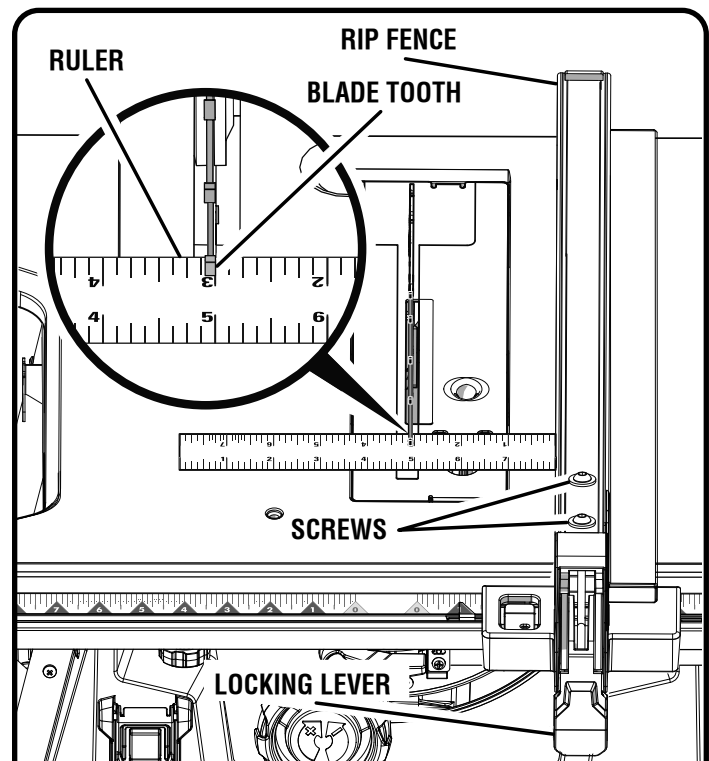

Fig. 67

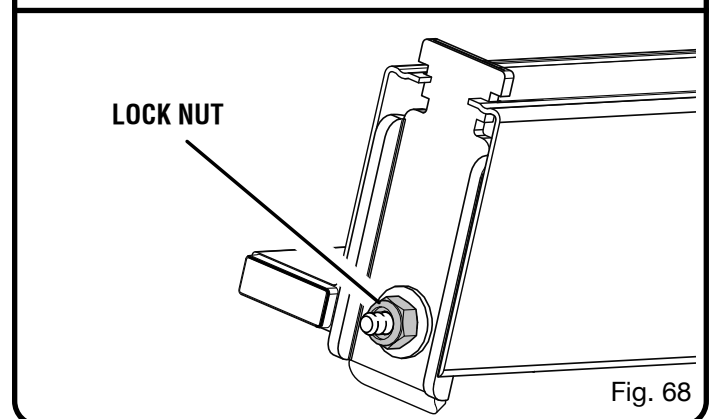

Fig. 68

# MAINTENANCE

## **⚠ WARNING:**

When servicing, use only identical replacement parts. Use of any other parts may create a hazard or cause product damage.

## **⚠ WARNING:**

Always wear eye protection with side shields marked to comply with ANSI Z87.1 during product operation. If operation is dusty, also wear a dust mask.

## **⚠ WARNING:**

Before performing any maintenance, make sure the tool is unplugged from the power supply and the top button on the switch is not depressed. Failure to heed this warning could result in serious personal injury.

## GENERAL MAINTENANCE

Avoid using solvents when cleaning plastic parts. Most plastics are susceptible to damage from various types of commercial solvents and may be damaged by their use. Use clean cloths to remove dirt, dust, oil, grease, etc.

## **⚠ WARNING:**

Do not at any time let brake fluids, gasoline, petroleum-based products, penetrating oils, etc., come in contact with plastic parts. Chemicals can damage, weaken, or destroy plastic which may result in serious personal injury.

- Periodically check all clamps, nuts, bolts, and screws for tightness and condition. Make sure the throat plate is in good condition and in position.
- Check the blade guard assembly for proper installation, fit, clearances, and for free movement. Some wood types may cause a buildup of dust, pitch, or resin on components, so regular maintenance and cleaning is recommended. Any cleaner used must be appropriate for use on plastic parts.
- **Clean plastic parts only with a soft damp cloth. Do not use any aerosol or petroleum solvents.**
- Protect the blade by cleaning out sawdust from underneath the table and in the blade teeth. Clean blade teeth with a solvent recommended for gum and pitch removal.
- To maintain the table surfaces, fence, and rails, periodically apply paste wax to them and buff to provide smooth functioning. To prevent work from slipping during cutting operation, **do not** wax the working face of the miter gauge.

## LUBRICATION

All of the bearings in this tool are lubricated with a sufficient amount of high grade lubricant for the life of the unit under normal operating conditions. Therefore, no further lubrication is required.

## CLEANING THE RIVING KNIFE LOCK LEVER PLATES

See Figure 69.

The lock lever on the riving knife may become difficult to lock securely after extended use due to sawdust or debris falling into the plates.

- Unplug the saw.
- Unlock the lever to remove the riving knife.
- Wipe the area with a clean dry cloth or use compressed air to blow away debris.
- Clean the riving knife.
- Reinstall the riving knife and turn the lever to lock the riving knife in place.

**NOTE:** If the lock lever is difficult to move or will not fully close after the plates have been cleaned, contact customer service.

## **⚠ WARNING:**

Do not use the saw if the lock lever does not fully close. Doing so may cause serious personal injury.

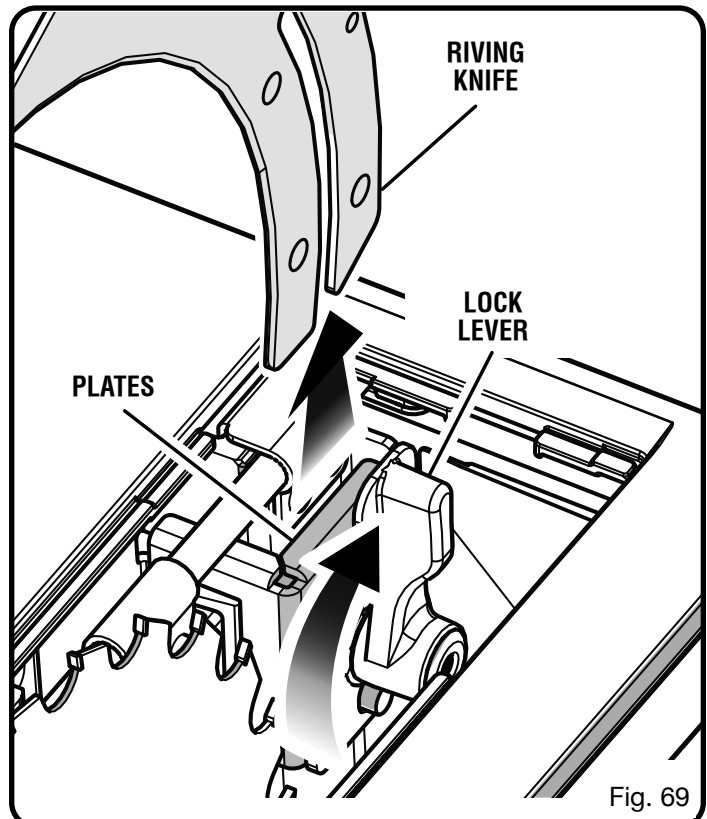

Fig. 69

# MAINTENANCE

## DUST CHUTE

See Figure 70.

This saw features a dust chute for convenience in discharging sawdust. A standard shop vac can be attached to the chute, located under the back side of the saw.

During periods of extended use, the dust chute should be emptied and cleaned to prevent buildup of sawdust and to make sure there are no obstructions or other small offcuts that may have fallen into the throat plate opening that could hinder maximum performance.

### To clean the dust chute:

- Unplug the saw.
- Loosen the screw at the bottom of the dust chute.
- Remove the cover.
- Shake out any sawdust and wipe with a clean dry cloth, as needed.
- Replace the cover and securely tighten the screw.

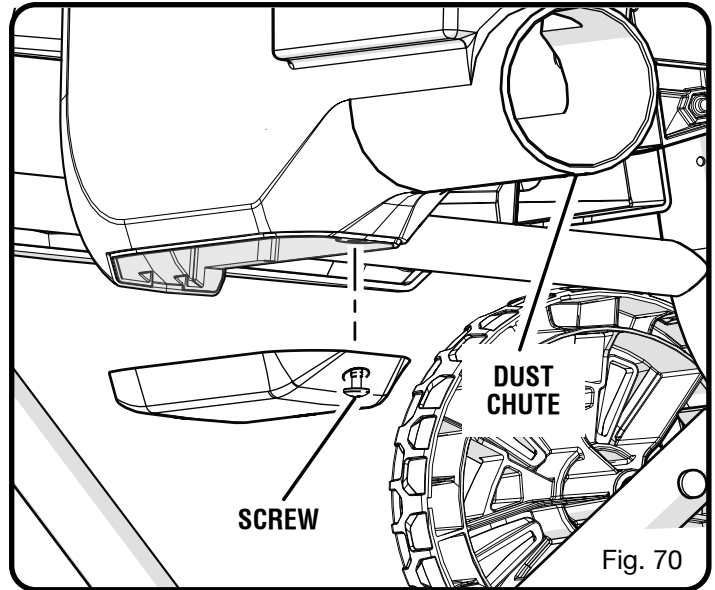

# ACCESSORIES

Look for these accessories where you purchased this product or call 1-800-525-2579:

- Dado Throat Plate .....089240035708

## **⚠ WARNING:**

Current attachments and accessories available for use with this product are listed above. Do not use any attachments or accessories not recommended by the manufacturer of this product. The use of attachments or accessories not recommended can result in serious personal injury.

# TROUBLESHOOTING

| Problem                           | Cause  | Solution   |
|-----------------------------------|--|--|
| Excess vibration.                 | Blade is out of balance.<br>Blade is damaged.<br>Saw is not mounted securely.<br>Work surface is uneven.<br><br>Blade is warped. | Replace blade.<br>Replace blade.<br>Tighten all hardware.<br>Reposition on flat surface. Adjust legs of optional stand.<br>Check saw blade installation. Replace blade if necessary. |
| Rip fence does not move smoothly. | Rip fence not mounted correctly.<br>Rails are dirty or sticky.<br>Clamp screw is out of adjustment.                              | Remount the rip fence.<br>Clean and wax rails.<br>Adjust clamp screw counterclockwise.   |
| Rip fence does not lock at rear.  | Clamp screw is out of adjustment.  | Adjust clamp screw clockwise.  |



# TROUBLESHOOTING

| Problem   | Cause   | Solution   |
|---|---|--|
| Cutting binds or burns work.  | Blade is dull.<br>Blade is heeling.<br><br>Work is fed too fast.<br>Rip fence is misaligned.<br>Workpiece is warped.<br><br>Riving knife is out of alignment. | Replace or sharpen blade.<br>See <b>Adjusting the Blade Parallel to the Miter Gauge Groove (Removing Heel)</b> .<br>Slow the feed rate.<br>Align the rip fence.<br>Replace the workpiece. Always cut with convex side to table surface.<br>See <b>To Check and Align the Riving Knife and Saw Blade</b> in the Assembly section. |
| Workpiece edges away from rip fence when ripping.                       | Blade not properly sharpened or set.  | Resharpener or set blade.  |
| Saw does not make accurate 90° or 45° cuts.                             | Positive stops behind the front panel need adjusting (Bevel Cuts).<br>Miter gauge is misaligned (Miter Cuts).   | Adjust positive stops.<br><br>Adjust the miter gauge.  |
| Height/bevel adjusting hand-wheel is hard to turn.                      | Gears or screw post behind the front panel are clogged with sawdust.  | Clean the gears or screw post.   |
| Saw does not start.   | Motor cord or wall cord is not plugged in.<br>Circuit fuse is blown.<br>Circuit breaker is tripped.<br>Cord or switch is damaged.                             | Plug in motor cord or wall cord.<br>Replace circuit fuse.<br>Reset circuit breaker.<br>Have the cord or switch replaced at your nearest authorized service center.   |
| Blade makes poor cuts.  | Blade is dull or dirty.<br>Blade is wrong type for cut being made.<br>Blade is mounted backwards.   | Clean, sharpen, or replace blade.<br>Replace with correct type.<br>Remount blade.  |
| Blade does not lower when turning height/bevel adjusting handwheel.     | Locking lever is not at full left position.   | Move locking lever to left.  |
| Motor labors in rip cut.  | Blade not proper for rip cut.   | Change blade; rip blade typically has fewer teeth.   |
| Blade coasts for longer than a few seconds after the saw is turned off. | Electric brake may not be working properly.   | Contact customer service.  |